

Date: _____ For: File Resubmit
 PO No.: _____ Approval Other _____
 Architect: _____ GC: _____
 Engr: _____ Mech: _____
 Rep: _____
(Company) (Project Manager)



ARNU543NKA4
 Multi V™ Vertical /Horizontal Air Handling Unit
 54,000 Btu/h Indoor Unit



Performance:

Cooling Mode:

Total Cooling Capacity (Btu/h)	54,000
Heating Capacity (Btu/h)	60,000
Power Input ¹ (W)	366

Cooling Nominal Test Conditions: Indoor: 80°F DB / 67°F WB
 Outdoor: 95°F DB / 75°F WB
 Heating Nominal Test Conditions: Indoor: 70°F DB / 59° WB
 Outdoor: 47°F DB / 43°F WB

Electrical²:

Power Supply (V/Hz/Ø)	208-230/60/1
Rated Amps (A)	1.80

Piping:

Refrigerant:

Liquid Line (in, OD)	3/8 bronze
Vapor Line (in, OD)	5/8 bronze

Condensate:

Condensate Line (in, ID)	1
Factory Installed Pump	No

Controls Features:

- Auto Operation
- Auto Changeover (Heat Recovery Only)
- Auto Restart
- Child Lock
- Dual Thermistor Control
- E.S.P. Control
- Group Control
- Hot Start
- Self Diagnostics
- Weekly Schedule
- Dual Setpoint Control
- Filter Life and Power Consumption Display
- External on/off control
- Timer (On/Off)
- Fan Speed Control

Optional Accessories:

- Wireless Remote Controller³ - PQWRHQ0FDB
- LG Programmable Controller - PREMTB10U
- LG Premium Controller - PREMTA000
- Simple Controller with Mode (Black) - PQRVCLOQ
- Simple Controller with Mode (White) - PQRVCLOQW
- Simple Controller without Mode (Black) PQRCHCAOQ
- Simple Controller without Mode (White) - PQRCHCAOQW
- Simple Dry Contact (1 contact, 24 VAC external power) - PDRYCB100
- Dry Contact for Economizer - PQDSBC1
- Dry Contact for Third Party Thermostat - PDRYCB300
- Wall Mounted Temperature Sensor - PQRSTA0

Entering Mixed Air:

Cooling Max ⁴ (°F WB)	76
Heating Min (°F DB)	59

Unit Data:

Refrigerant Type	R410A
Refrigerant Control	EEV
Sound Pressure ⁵ dB(A) (H/M/L)	50/49/47
Net Unit Weight (lbs)	165
Shipping Weight (lbs)	181

Fan:

Type	Sirocco
Fan Quantity:	1
Motor/Drive:	Brushless Digitally Controlled/Direct
Motor Quantity:	1
High Mode Airflow Rate H/M/L (CFM):	1,475/1,400/1,260
High Mode External Static Pressure (ESP) ⁶ (in wg):	0.5
Standard Mode Airflow Rate H/M/L (CFM):	1,475/1,400/1,260
Standard Mode External Static Pressure (ESP) ⁶ (in wg):	0.3
Minimum ESP (in wg) ⁷ :	0.1
Maximum ESP (in wg) ⁷ :	1.0

Standard Features:

- Access Panel for Field Supplied Air Filter
 •(20 x 24 x 1)

Notes:

- 1.The Power Input is rated at high speed.
- 2.Electrical data listed is without an electric heat kit accessory option. The addition of an electric heat kit accessory option will change the electrical data.
3. Requires an LG wall controller because ducted units don't have an infrared receiver.
- 4.See Engineering Manual for sensible and latent capacities.
- 5.Sound pressure levels are tested in an anechoic chamber under ISO Standard 3745.
6. At factory fan speed setting.
7. Maximum static pressure may result in reduced airflow (CFM).
- 8.All communication cable to be minimum 18 AWG, 2-conductor, stranded, shielded and must comply with applicable local and national code.
- 9.Power wiring cable size must comply with the applicable local and national code.
- 10.Adjust fan speed to correct for static pressure increases when using field supplied air filter or heat kit.
- 11.Must follow installation instructions in the applicable LG installation manual.



ARNU543NKA4

Multi V™ Vertical /Horizontal Air Handling Unit

54,000 Btu/h Indoor Unit



Tag #:

Date:

PO No.:

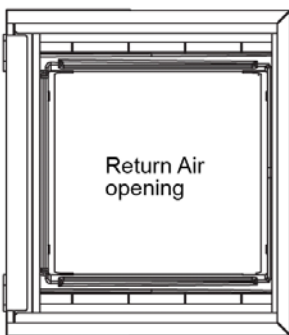
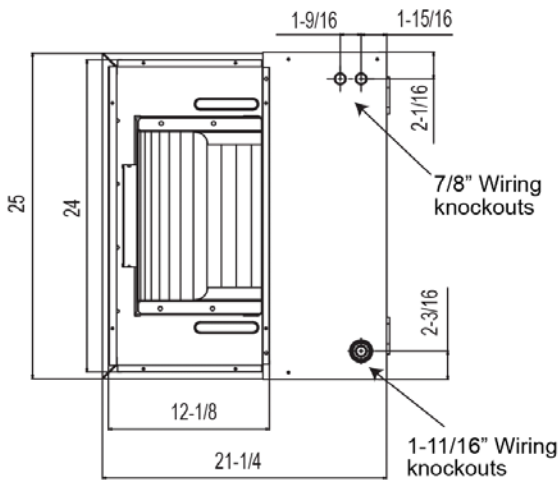
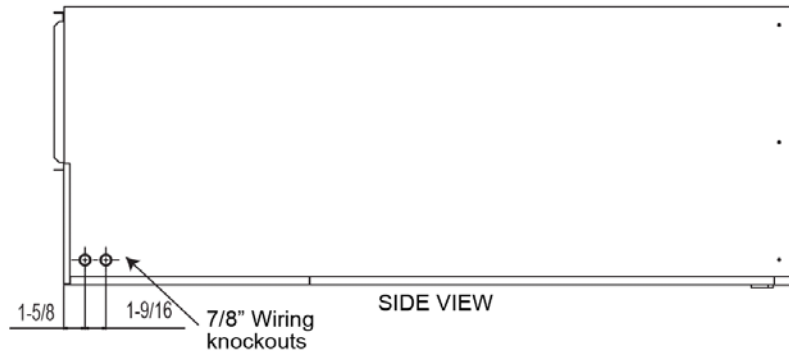
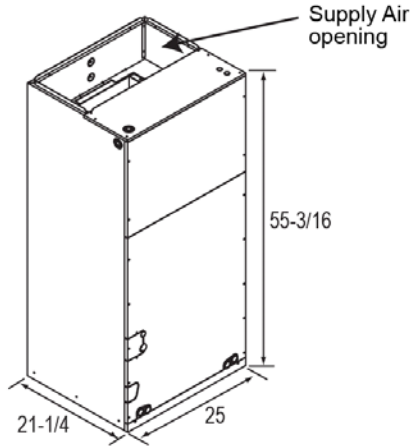

Unit: inches

Note: All measurements have a tolerance of $\pm 1/4$ in.

