

MULTI VTM **MINI**

Engineering Manual

Air Source Heat Pump VRF System Condensing Unit

Variable Refrigerant Flow
Air-Cooled
3.0 – 4.4 Tons



PROPRIETARY DATA NOTICE

This document, as well as all reports, illustrations, data, information, and other materials is the property of LG Electronics U.S.A., Inc.

EM_MultiVMini_5_15

For continual product development, LG reserves the right to change specifications without notice.
©LG Electronics U.S.A., Inc.



About LG Electronics, Inc.

LG Electronics, Inc. is a global leader and technology innovator in consumer electronics, mobile communications, and home appliances. LG Electronics comprises four business units—Home Entertainment, Mobile Communications, Home Appliance, and Air Conditioning and Energy Solutions. LG is one of the world's leading producers of flat panel televisions, audio and video products, mobile handsets, compressors, air conditioners, and washing machines. LG's commercial air conditioning business unit was established in 1968 and has built its lineup of residential and commercial products to include VRF, Multi-Zone systems, Duct Free Split Systems, Packaged Terminal Air Conditioners (PTACs), and room air conditioners. In 2011, the air conditioning and energy solutions business unit grew to include LED lighting and solar products. For more information visit www.lg.com.

Quality Commitment

LG is committed to the success of every Multi V project by providing the best industry technical support during project engineering, installation, and commissioning. LG offers a variety of classes designed for engineers, architects, installers, and servicers to ensure that every Multi V installation is completed successfully. Classes are conducted at LG's training centers and in field locations at various times throughout the year and upon special request.

Variable Refrigerant Flow (VRF) Technology

In the early 1980s, VRF technology was introduced to the world as an alternative method of cooling and heating in commercial structures designed to minimize energy consumption. VRF systems have become the system of choice for designers internationally because these systems offer better comfort at substantially lower operating costs when compared to traditional HVAC systems. Older systems are being replaced with newer more efficient systems making VRF a viable option. Today, VRF is gaining popularity in the United States. LG air-source systems offer the opportunity to eliminate ductwork in the same configuration. The systems offer zoning without the need for zone damper systems. The advanced controls provide exceptional building dehumidification and temperature control and can rapidly adapt system operating parameters to the ever changing building load.



TABLE OF CONTENTS

INTRODUCTION.....	7
ArchitecturalAppeal.....	8
EngineersAdvantage.....	9
PRODUCTDATA.....	11
ProductFeaturesandBenefits.....	12
UnitNomenclature.....	13
GeneralData.....	14
PERFORMANCE DATA.....	25
Cooling Capacity.....	26
HeatingCapacity.....	35
UnitRefrigerantFlowDiagrams.....	44
OutdoorWiringDiagram.....	46
SYSTEMENGINEERING.....	47
BuildingVentilation.....	48
EquipmentSelectionProcedure.....	51
PlacementConsiderations.....	57
ClearanceRequirements.....	59
LATSMultiVPipeSystemDesignTool.....	61
PipeDesignParameters.....	62
PipeLayoutProcedure.....	63
PipingDesignGuide.....	66
JobsiteConnections.....	77
MiniRefrigerantCharge.....	79
CUTSHEETS.....	81
DimensionalDataandWeights.....	82
PipeandElectricalConnections.....	83
Y-BranchKits.....	84
HeaderKits.....	85
U.S. DESIGN STANDARDS.....	87
ASHRAEStandardsSummary.....	88
ASHRAEStandard15-2004andASHRAEStandard34-2007.....	88
ASHRAEStandard62.1-2010.....	90
BuildingSustainability.....	92
USGBC—LEEDGreenBuildingRatingSystem.....	93
SPECIFICATIONS.....	95
MechanicalSpecifications.....	96
ACRONYMS.....	98

INTRODUCTION

"Architectural Appeal" on page 8

"Engineers Advantage" on page 9

Benefits of the Multi V Mini

- Maximum individual occupant control
- Longest refrigerant piping lengths
- Highest elevation differences
- Maximum flexibility
- Quiet and comfortable environment
- Reduced or eliminated ductwork

Multi V Mini

Multi V Mini is among the industry's best with vertical rise and piping lengths, so choosing the LG Multi V Mini variable refrigerant flow system provides the system designer with the most freedom and flexibility while engineering the refrigerant pipe system. Multi V Mini is a two-pipe heat pump system available in nominal capacities of 3.0, 4.0, and 4.4 tons. It is best suited for applications with zones that require heating or cooling, such as residences and small office buildings. The Multi V Mini allows the designer to accommodate up to 9 thermal zones, each controlled from a separate controller. Mini outdoor units are available in 208–230V/60Hz/1Ph.

Adaptable and Flexible

Multi V outdoor units can be adapted to a wide range of building types and sizes, such as schools, hotels, hospitals, offices, and residences. The light weight and small footprint allows the system components to be placed in the building without expensive cranes, easily fitting into most service elevators and set in place with minimal requirements for structural reinforcements. The system's modular design means Multi V can be commissioned in stages so tenants can move in as each floor or even each room is completed.

Multi V technology allows you to pipe farther by reaching areas of the building that would require the installation of a second system when using traditional direct-expansion cooling and heating equipment. Multi V provides the designer with uncompromised pipe system engineering flexibility—the longest pipe runs and the largest elevation differences. Whether your building is a high-rise condominium, a hotel, a sprawling school, an office complex or high-end residence, the Multi V family of products is best suited to reach the farthest corners and elevations of the building from a single outdoor unit location.

Smaller Chases and Plenums

The LG Multi V system uses refrigerant piping to move heat resulting in smaller space requirements compared to water piping or air ducts. This helps reduce the overall construction and material cost of your building and gives back leasable space. Flexible and logical placement of system components, shorter pipe lengths, and fewer joints lowers installation costs.

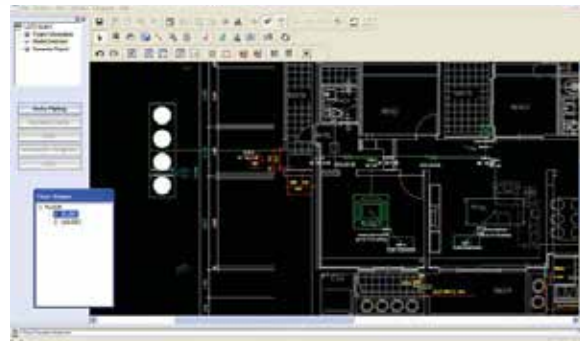
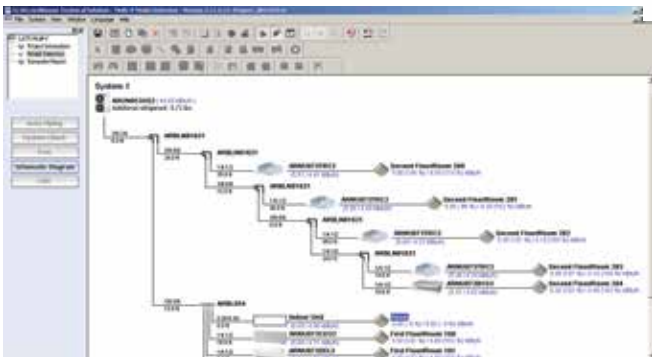


MULTI VTM
MINI



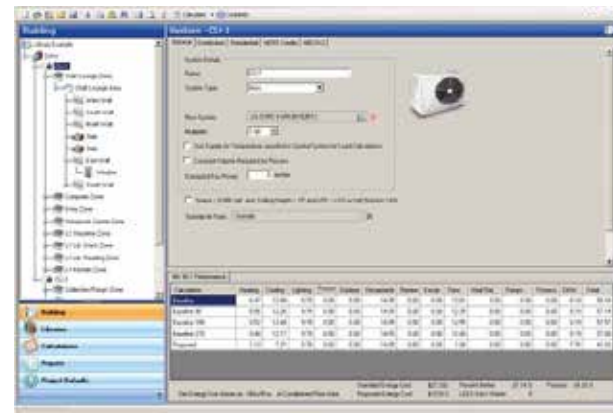
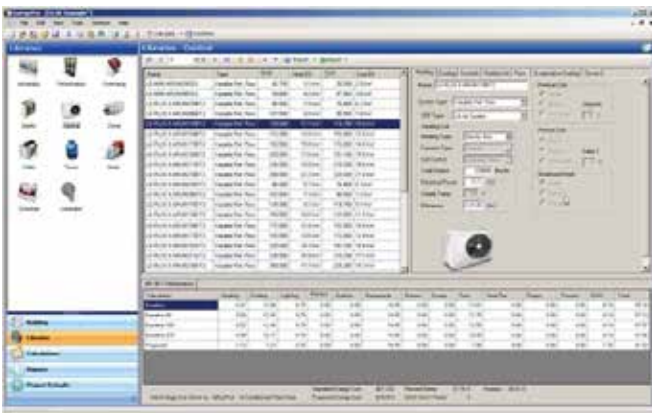
Intuitive Design

The LATS (LG Air Conditioning Technical Solution) Multi V design and layout software provides an intuitive, quick, and simple method to design a Multi V Mini refrigerant pipe system. LATS Multi V checks piping lengths and elevations, and it assists with the sizing of indoor and outdoor units by calculating component capacity based on design conditions. LATS Multi V is the industry's only software that can import AutoCAD™ drawings and lay out the Multi V system to scale. When the designer finishes the AutoCAD system layout, all of the piping lengths will be calculated, and a drawing file with the Multi V system will be available for export and integration into the building drawing set.



Energy Modeling

LG stands behind efficiency and performance. You will find Multi V in the EnergyPro building energy simulation software from EnergySoft®. EnergyPro is approved by the California Energy Commission to accurately model and provide necessary documentation to comply with the rigorous California Title 24 Standards, ASHRAE 90.1 compliance, and to calculate the number of LEED Energy and Atmosphere Credit 1 (EA-1)—Building Energy Efficiency credits earned by the design team. The software accurately models energy consumption and utility costs based on building design, orientation, location, and other design conditions.



PRODUCT DATA

"Product Features and Benefits" on page 12

"Unit Nomenclature" on page 13

"General Data" on page 14

System Controls

Refrigerant Distribution Balancing

Buildings with hydronic heating systems can experience low delta-T syndrome—a condition that occurs when the water distribution system is not properly balanced. Units located at the ends of the hot water piping system need boiler water while units located closer to the boiler use too much water. Low delta-T syndrome also occurs in VRF systems. To prevent this condition in Multi V installations, LG provides control algorithms that automatically monitor and balance the distribution of refrigerant to indoor units during high demand periods. This allows each unit to receive an appropriate amount of refrigerant.

Low Noise Levels

LG customers often ask if the outdoor unit is running after commissioning is complete. When Multi V outdoor units operate fully loaded, they have one of the quietest noise levels in the industry. Noise is almost undetectable during off-peak operation. To promote a quiet, comfortable environment, the LG Multi V indoor units operate at sound levels as low as 23dB(A) and outdoor units as low as 50dB(A) at full load.

All rotating components are soft-started by the controller using digitally-controlled inverters, which reduces undesirable noise caused by fans and compressors cycling.

Comfort Control at Its Best

Tight temperature control through precise load matching maximizes the time that the indoor units remove moisture. This ensures maximum comfort and delivers the industry's best indoor humidity levels.

Precision Load Matching

Unlike traditional air conditioning control systems, which use thermostatic controls to maintain room temperatures, LG Multi V controls continuously vary the indoor unit fan speed and refrigerant flow indirectly providing lower and more consistent humidity levels in the conditioned space. The longer the indoor coil temperature is below the dew-point of the room in conjunction with air movement across the coil, the space humidity level will vary little compared to technologies that cycle fans and compressors multiple times per hour.

The outdoor unit responds by varying the compressor speed and outdoor fan motors as needed to maintain system operating pressure. As a result, the Multi V system delivers precise space temperature control.

Heat Transfer Efficiency

Fin Design

All Multi V outdoor units are provided with large surface coils made of copper tubes with aluminum fins designed to maximize unit operating efficiency over a wide range of ambient conditions.

GoldFin™ Coating

Standard from the factory, every LG Multi V outdoor coil fin surface is coated with LG's exclusive GoldFin™ anti-corrosive protective coating designed to prevent natural surface corrosion of the aluminum fins. This maintains heat transfer properties of the coil for an extended time.

A hydrophilic coating is applied to the outdoor unit coil fin surface over the GoldFin coating. This coating enhances the development of heavier water droplets gathering on the fin surface. As a result, the droplets roll off the fin surfaces delaying the point when frost forms on the coil surface during heating operations. This coating also makes it possible to easily clean the outdoor unit coil using mild soap.

Simplified Installation

Cooling and heating systems that use the LG Multi V simplify and reduce the mechanical and control system design time. The designer no longer has to be concerned with interconnecting chilled and condenser water piping, air distribution duct systems, matching and selecting chillers, towers, pumps, coils, fans, air handlers, or variable air volume (VAV) boxes.

System integration with existing building management systems has never been easier. Since all of the Multi V system components are engineered and provided by LG, the system components and controls come pre-engineered and do not need any custom programming from third-party contractors.

Advanced Compressor Technology

Oil Management

Oil migration is no longer a concern when choosing Multi V. A three-stage oil management system ensures a safe level of oil in the compressor sump. An oil injection mechanism provides a consistent film of oil on moving parts, even at low speeds, which enables LG's inverter compressor operation down to 25 Hz.

1. The compressor discharge is specially designed to minimize the amount of oil leaving

the compressor.

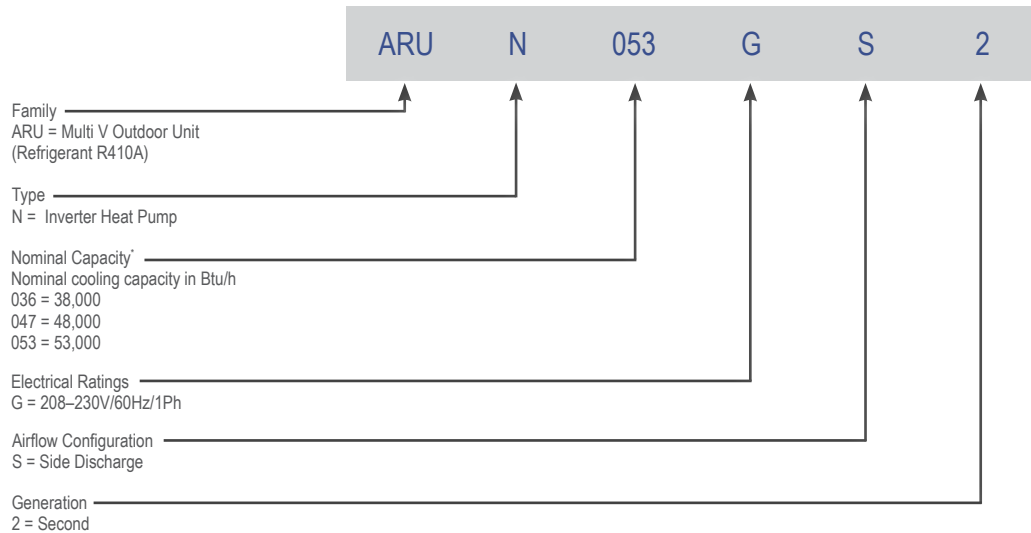
2. An oil separator located on the discharge side of the compressor(s) separates the majority of oil mixed with the refrigerant gas stream during compression. Oil is returned to the compressor through a gravity drain.
3. Oil return algorithms flush the oil from the distribution system back to the compressor.

Inverter Driven

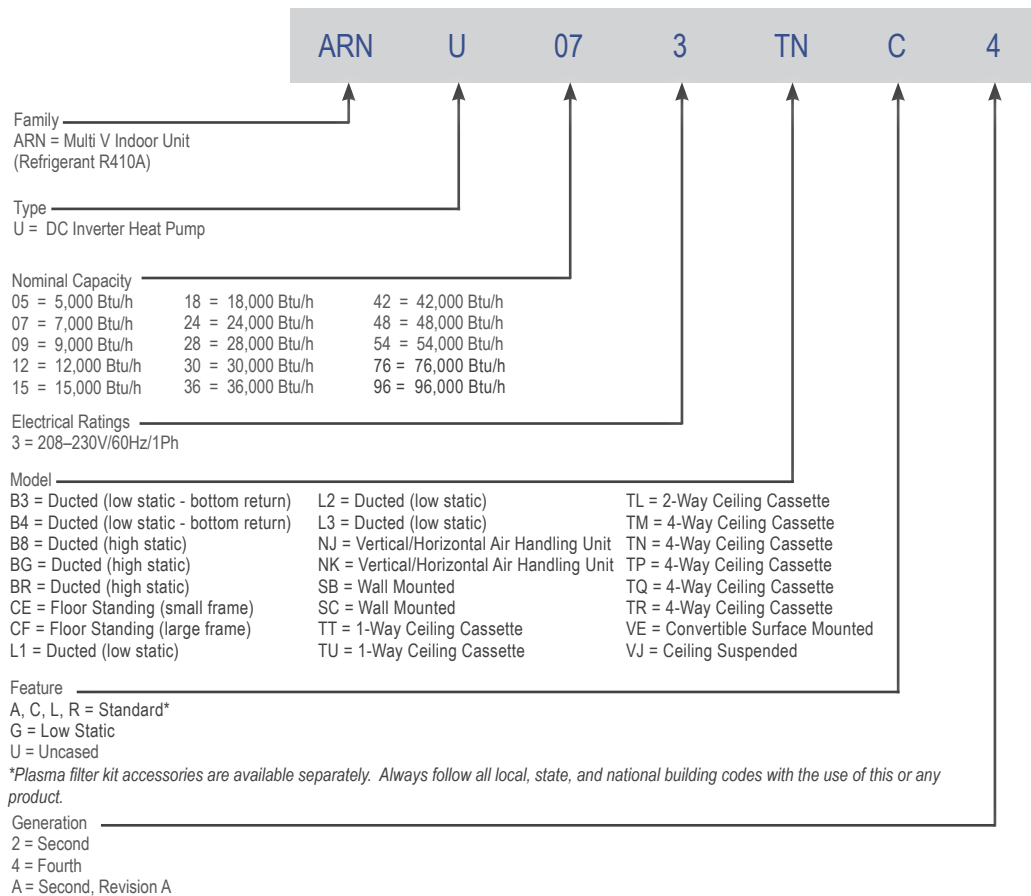
The R410A rotary compressor is optimized to maximize compressor efficiency, which reduces power consumption and monthly utility bills. The latest inverter technology allows the LG Multi V to vary the compressor motor shaft speed to deliver an appropriate amount of cooling to all indoor units. Precise refrigerant volume delivery translates into long periods of time with coil surface temperatures below dew point and minimizes compressor and fan component run time. Occupants remain comfortable while utility costs are reduced.



Outdoor



Indoor



Note: * Nominal capacity is obtained when applied with non-ducted indoor unit.

GENERAL DATA



Outdoor Units

Table 1a: General Data—Outdoor Units

	3.0 Ton ARUN036GS2	4.0 Ton ARUN047GS2	4.4 Ton ARUN053GS2
Cooling Mode Performance			
Nominal Cooling Capacity (Btu/h)	39,500	50,000	55,500
Rated Cooling Capacity (Btu/h) ³	38,000	48,000	53,000
Heating Mode Performance			
Nominal Heating Capacity (Btu/h)	44,000	56,000	61,500
Rated Heating Capacity (Btu/h) ³	42,000	53,500	59,000
Operating Range			
Cooling (°F DB)	23–118	23–118	23–118
Heating (°F)	(-4)–60	(-4)–60	(-4)–60
Compressor			
Inverter Rotary Quantity	1	1	1
Oil / Type	PVE / FVC68D	PVE / FVC68D	PVE / FVC68D
Full Load Operating RPM	3600	3600	3600
Unit Data			
Refrigerant Type	R410A	R410A	R410A
Refrigerant Control / Location	EEV / Indoor Unit	EEV / Indoor Unit	EEV / Indoor Unit
Maximum Number Outdoor Units / System ¹	1	1	1
Maximum Number Indoor Units / System ¹	6	8	9
Minimum Number Indoor Units / System ¹	1	1	1
Qty Refrigeration Circuits	1	1	1
Sound Pressure Cooling / Heating dB(A) ⁵	50 / 52	51 / 53	52 / 54
Net Unit Weight (lbs)	234	234	234
Shipping Weight (lbs)	258	258	258
Communication Cable (Qty # Wires / Gauge) ²	2 / 18	2 / 18	2 / 18
Fan			
Type	Propeller (BLDC)	Propeller (BLDC)	Propeller (BLDC)
Qty / Motor HP	2 / 0.166	2 / 0.166	2 / 0.166
Qty / Diameter (in)	2 / 20.75	2 / 20.75	2 / 20.75
Motor / Drive	Brushless Digitally-Controlled / Direct	Brushless Digitally-Controlled / Direct	Brushless Digitally-Controlled / Direct
Operating Range (RPM)	80–950	80–950	80–950
Maximum Air Volume (CFM)	3,885	3,885	3,885
Maximum External Static Pressure (in-wg)	0.16	0.16	0.16
Airflow Direction	Horizontal—Back to Front	Horizontal—Back to Front	Horizontal—Back to Front

- The System Combination Ratio must be between 50–130%. See page 55 for more information.
- All communication cables must comply with applicable local codes.
- Rated using non-ducted indoor units. Rated 0 ft. above sea level with 25 ft. of refrigerant line per indoor unit and a 0 ft. level difference between outdoor and indoor units. All capacities are net with a Combination Ratio between 95–105%. Certified under the AHRI Unitary Small Heat Pump equipment certification program and tested per AHRI Standard 210/240 conditions and in accordance with DOE test procedures. Nominal Cooling capacity rating obtained with air entering the indoor coil at 80°F dry bulb (DB) and 67°F wet bulb (WB) and outdoor ambient conditions of 95°F dry bulb (DB) and 75°F wet bulb (WB). Nominal Heating capacity rating obtained with air entering the indoor unit at 70°F dry bulb (DB) and 59°F wet bulb (WB) and outdoor ambient conditions of 47°F dry bulb (DB) and 43°F wet bulb (WB).
- Unit is capable of operating outside the operating range temperature limitations. See "Select the Outdoor Unit" on page 52.
- Sound pressure levels are tested in an anechoic chamber under ISO Standard 1996.
- Power wiring cable is field provided and must comply with the applicable local and national codes.

Table 1b: General Data—Outdoor Units (continued from Table 1a)

	3.0 Ton ARUN036GS2	4.0 Ton ARUN047GS2	4.4 Ton ARUN053GS2
Heat Exchanger			
Material	Copper Tube / Aluminum Fin	Copper Tube / Aluminum Fin	Copper Tube / Aluminum Fin
Fin Coating	GoldFin™ / Hydrophilic	GoldFin™ / Hydrophilic	GoldFin™ / Hydrophilic
Face Area (ft²)	630.7	630.7	630.7
Rows / Fins per inch	2 / 17	2 / 17	2 / 17
Piping			
Liquid Line Connection (in, OD)	3/8 Braze	3/8 Braze	3/8 Braze
Vapor Line Connection (in, OD)	5/8 Braze	5/8 Braze	3/4 Braze
Factory Refrigerant Charge			
Factory Charge—lbs of R410A	6.6	6.6	6.6

Refer to "Pipe Design Parameters" on page 62 and "Piping Design Guide" on page 66 for correct line sizing. Designer must verify refrigerant piping design configuration using LATS Multi V software.

The factory's refrigerant charge is sufficient when line set length does not exceed 25 ft. Estimated charge per linear foot. Actual refrigerant charge varies and can be calculated

using LG's LATS computerized refrigerant piping software or manually using the worksheet on page 80. System must be charged using a refrigerant charging scale. Superheat method will not work.

Table 2: Electrical Characteristics—Outdoor Unit 60 Cycle Compressor and Fan Motors

Nom. Tons	Unit Model No.	Unit Operating Voltage Range	MCA	MOP	Compressor Motor				Fan Motor(s)				
					No.	Volts	Phase	Amps	No.	Volts	Phase	Amps	
								RLA(ea.)				FLA(ea.)	kW
3.0	ARUN036GS2	187–253	29.0	50	1	208–230	1	21.5	2	208–230	1	1	0.35
4.0	ARUN047GS2	187–253	33.0	55	1	208–230	1	24.8	2	208–230	1	1	0.35
4.4	ARUN053GS2	187–253	34.0	60	1	208–230	1	25.9	2	208–230	1	1	0.35

MCA = Minimum Circuit Ampacity
Voltage tolerance is ±10%
Maximum allowable voltage unbalance is 2%

HACR type circuit breaker per NEC
MOP (Maximum Overcurrent Protection) is calculated as follows:

(Largest motor FLA x 2.25) + (Sum of other motor FLA) rounded down to the nearest standard fuse size

Acoustic Data

Table 3: Outdoor Unit Sound Pressure Level

Model	Cooling Operation dB(A)		Heating Operation dB(A)	
	Peak	Off-Peak	Peak	Off-Peak
ARUN036GS2	50	40–46	52	41–47
ARUN047GS2	51	41–47	53	42–48
ARUN053GS2	52	42–48	54	43–49

Sound pressure levels are tested in an anechoic chamber under ISO Standard 1996. Measurements are taken with no attenuation and units operating at full load nominal operating condition. Measurements are taken 4.9 ft. above the

finished floor and a distance of 3.3 ft. from the face of the fan discharge. Sound Power Levels are measured in db(A) with a tolerance of ± 3. Off-Peak Operation: Logic takes advantage of lower outdoor ambient temperatures and limits

the outdoor unit fan speed during off peak operation to lower the unit sound power level. Actual sound levels depend on room conditions and natural attenuation.

GENERAL DATA



Acoustical Data—Outdoor Units

Figure 1: ARUN036GS2 (Cooling)

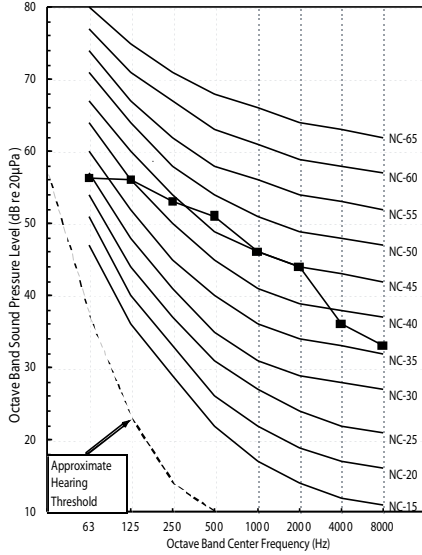


Figure 2: ARUN047GS2 (Cooling)

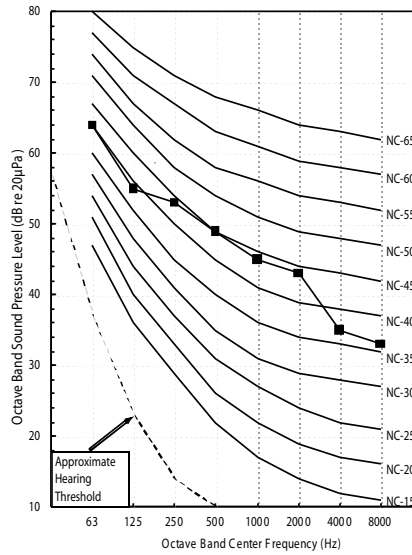


Figure 3: ARUN053GS2 (Cooling)

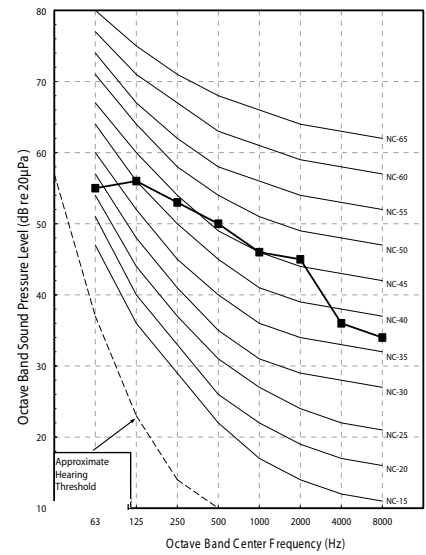


Figure 4: ARUN036GS2 (Heating)

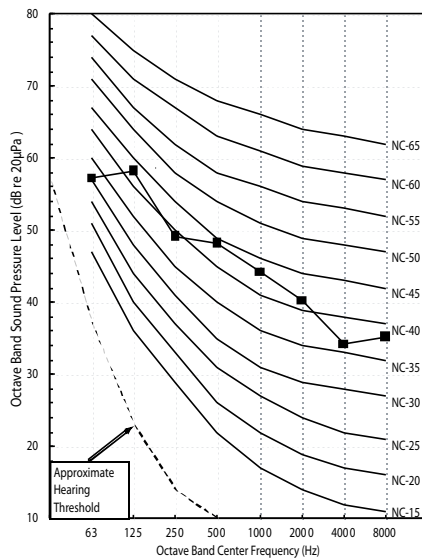


Figure 5: ARUN047GS2 (Heating)

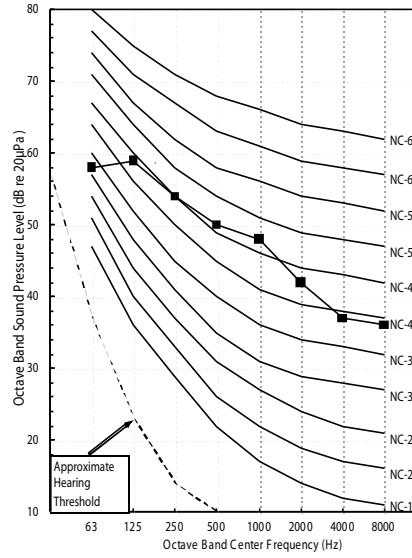
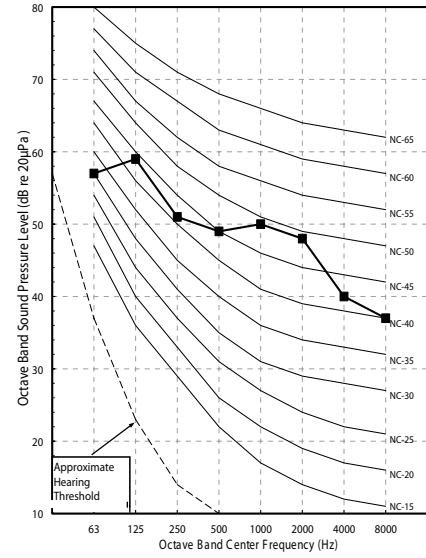





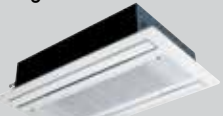


Figure 6: ARUN053GS2 Heating



All data is measured in accordance with Industry Standard ISO 1996. Measurements are taken 4.9 ft. above the finished floor and a distance of 3.3 ft. from the face of the fan discharge with no attenuation.



Table 4a: Summary Data—Wall and Ceiling Flush Mounted Indoor Units

Unit/Type ¹	ARNU****2	Dimensions (W x D x H) (inches)	Nominal Capacity Btu/h		Air Flow Rate (CFM) (H/M/L ⁴)	Weight (lbs.)	Pipe Connections (inches, O.D.) (Liquid, Vapor)
			Cooling ³	Heating ³			
Wall Mounted—ART COOL™ Mirror 	053 SBR4	35-1/4 x 8-1/8 x 11-7/16	5,500	6,100	230/212/194	24	1/4, 1/2
	073 SBR4		7,500	8,500	247/230/194		
	093 SBR4		9,600	10,900	290/247/194		
	123 SBR4		12,300	13,600	336/290/230		
	153 SBR4	15,400	17,100	371/318/247			
	183 SCR4	40-9/16 x 9-11/16 x 12-13/16	19,100	21,500	441/424/399	34	3/8, 5/8
243 SCR4	24,200		27,300	494/449/406			
Wall Mounted—Standard 	053 SBL4	35-1/4 x 8-15/16 x 11-7/16	5,500	6,100	1,120/1,080/1,050	22	1/4, 1/2
	073 SBL4		7,500	8,500	1,190/1,120/1,050		
	093 SBL4		9,600	10,900	1,260/1,190/1,050		
	123 SBL4		12,300	13,600	1,420/1,260/1,120		
	153 SBL4	15,400	17,100	1,550/1,350/1,190			
	183 SCL4	40-5/16 x 9-7/8 x 12-13/16	19,100	21,500	1,120/1,050/980	31	3/8, 5/8
243 SCL4	24,200		27,300	1,280/1,140/1,000			
Ceiling Cassette—One Way 	073 TUC4	Body: 33-7/8 x 17-3/4 x 6-11/16 Panel: 43-5/16 x 19-3/4 x 1-3/8	7,500	8,500	290/258/226	Body: 33 Panel: 10	1/4, 1/2
	093 TUC4		9,600	10,900	325/304/290		
	123 TUC4		12,300	13,600	353/325/290		
	183 TTC4	Body: 46-1/2 x 17-3/4 x 6-7/8 Panel: 55-15/16 x 19-3/4 x 1-3/8	19,100	21,500	470/427/385	Body: 42 Panel: 13	3/8, 5/8
	243 TTC4		24,200	24,200	515/470/406		
Ceiling Cassette—Two Way 	183 TLC4	Body: 32-11/16 x 21-5/8 x 8-7/8 Panel: 41-5/16 x 25-3/16 x 1-5/8	19,100	21,500	459/424/353	Body: 49 Panel: 11	1/4, 1/2
	243 TLC4		24,200	27,300	601/530/459		
Ceiling Cassette—Four Way (2' x 2') 	053 TRC4	Body: 22-7/16 x 22-7/16 x 8-7/16 Panel: 27-9/16 x 27-9/16 x 7/8	5,500	6,100	265/247/212	Body: 29 Panel: 7	1/4, 1/2
	073 TRC4		7,500	8,500	265/247/212		
	093 TRC4		9,600	10,900	283/265/251		
	123 TRC4		12,300	13,600	307/283/247		
	153 TQC4	Body: 22-7/16 x 22-7/16 x 10-3/32 Panel: 27-9/16 x 27-9/16 x 7/8	15,400	17,100	388/353/328	Body: 35 Panel: 7	
	183 TQC4		19,100	21,500	396/388/353		
Ceiling Cassette—Four Way (3' x 3') 	243 TPC4	Body: 33-1/16 x 33-1/16 x 8 Panel: 37-3/8 x 37-3/8 x 1-7/16	24,200	27,300	600/530/459	Body: 48 Panel: 13	3/8, 5/8
	283 TPC4		28,000	31,500	671/565/494		
	073 TNA4	Body: 33-1/16 x 33-1/16 x 9-11/16 Panel: 37-3/8 x 37-3/8 x 1-7/16	7,500	8,500	459/424/388	Body: 54 Panel: 13	
	093 TNA4		9,600	10,900	477/424/388		
	123 TNA4		12,300	13,600	494/459/424		
	153 TNA4		15,400	17,100	530/459/424		
	183 TNA4		19,100	21,500	565/530/424		
	243 TNA4		24,200	27,300	742/671/600		
	363 TNC4	36,200	40,600	883/777/706			
	243 TMA4	Body: 33-1/16 x 33-1/16 x 11-5/16 Panel: 37-3/8 x 37-3/8 x 1-7/16	24,200	27,300	777/706/635	Body: 59 Panel: 13	
	283 TMA4		28,000	31,500	812/741/635		
	363 TMA4		36,200	40,600	918/812/706		
	423 TMC4		42,000	43,800	1,059/918/812		
	483 TMC4		48,100	51,200	1,130/953/883		

¹All indoor units require 208–230V/60Hz/1Ph and an AWG18-2 communication cable.

²Model number shows nominal capacity and frame size designator.

³Nominal cooling capacity rating obtained with air entering the indoor unit at 80°F dry bulb (DB) and 67°F wet bulb (WB) and outdoor ambient conditions of 95°F dry bulb (DB) and 75°F wet bulb (WB).

Nominal heating capacity rating obtained with air entering the indoor unit at 70°F dry bulb (DB) and 60°F wet bulb (WB) and outdoor ambient conditions of 47°F dry bulb (DB) and 43°F wet bulb (WB).



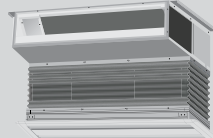

⁴H/M/L = High/Medium/Low

GENERAL DATA



Indoor Units

Table 4b: Summary Data—Ducted Indoor Units

Unit/Type ¹	ARNU**** ²	Dimensions (W x D x H) (inches)	Nominal Capacity Btu/h		Air Flow Rate (CFM) (H/M/L ⁴)	Weight (lbs.)	Pipe Connections (inches, O.D.) (Liquid, Vapor)	Max. ESP (inches)	
			Cooling ³	Heating ³					
	073 BGA4	46-1/2 x 17-3/4 x 11-3/4	7,500	8,500	441/406/332	84	3/8, 5/8	0.62	
	093 BGA4		9,600	10,900	452/406/332				
	123 BGA4		12,300	13,600	477/427/332				
	153 BGA4		15,400	17,100	487/417/293				
	183 BGA4		19,100	21,500	537/487/417				
	243 BGA4		24,200	27,300	671/537/487				
	283 BGA4		28,000	31,500	915/851/770				
	363 BGA4		36,200	40,600	1,141/1,024/894				
	423 BGA4	42,000	43,800	1,218/1,141/1,084					
	483 BRA4	48-7/16 x 23-3/8 x 15	48,100	51,200	1,568/1,395/1,183	112		0.78	
	543 BRA4		54,000	61,400	1,819/1,678/1,395				
	763 B8A4	61-1/2 x 27-1/8 x 18-1/8	76,400	86,000	2,050/1,766/1,766	192	3/8, 3/4	0.98	
	963 B8A4		95,900	107,500	2,542/2,260/2,260		3/8, 7/8		
	073 L1G4	27-9/16 x 27-9/16 x 7-1/2	7,500	8,500	270/230/200	39	1/4, 1/2	0.19	
	093 L1G4		9,600	10,900	320/250/200				
	123 L2G4	35-7/16 x 27-9/16 x 7-1/2	12,300	13,600	360/310/250	51			
	153 L2G4		15,400	17,100	450/360/310				
	183 L2G4		19,100	21,500	530/450/360				
	243 L3G4		24,000	27,300	710/570/430				
	073 B3G4	32-5/8 x 22-5/8 x 7-1/2	7,500	8,500	283/229/194	46	1/4, 1/2	0.15	
	093 B3G4		9,600	10,900	318/247/212				
	123 B3G4		12,300	13,600	353/283/229				
	153 B3G4		15,400	17,100	388/353/283				
	183 B4G4	43-5/16 x 22-5/8 x 7-1/2	19,100	21,500	494/424/353	57			3/8, 5/8
	243 B4G4		24,200	27,300	600/530/353				
	123 NJA4	18 x 21-1/4 x 48-11/16	12,000	13,500	530/480/380	117	1/4, 1/2	1.0	
	183 NJA4		18,000	20,000	580/530/480				
	243 NJA4		24,000	27,000	710/640/480				
	303 NJA4		30,000	34,000	880/800/630				
	363 NJA4		36,000	40,000	990/880/800				
	423 NKA4	25 x 21-1/4 x 55-3/16	42,000	46,000	1,250/1,100/1,000	121	3/8, 5/8		
	483 NKA4		48,000	54,000	1,400/1,260/1,000				
	543 NKA4		54,000	60,000	1,475/1,400/1,260				

¹All indoor units require 208–230V/60Hz/1Ph and an AWG18-2 communication cable.

²Model number shows nominal capacity and frame size designator.

³Nominal cooling capacity rating obtained with air entering the indoor unit at 80°F dry bulb (DB) and 67°F wet bulb (WB) and outdoor ambient conditions of 95°F dry bulb (DB) and 75°F wet bulb (WB).

Nominal heating capacity rating obtained with air entering the indoor unit at 70°F dry bulb (DB) and 60°F wet bulb (WB) and outdoor ambient conditions of 47°F dry bulb (DB) and 43°F wet bulb (WB).

⁴H/M/L = High/Medium/Low

Product Data

Table 5: Summary Data—Suspended and Surface Mounted Indoor Units

Unit/Type ¹	ARNU**** ²	Dimensions (W x D x H) (inches)	Nominal Capacity Btu/h		Air Flow Rate (CFM) (H/M/L ⁴)	Weight (lbs.)	Pipe Connections (inches, O.D.) (Liquid, Vapor)
			Cooling ³	Heating ³			
Ceiling Suspended 	183VJA2	37-7/16 x 8-11/16 x 25-5/8	19,100	21,500	565/495/424	55	1/4, 1/2
	243VJA2		24,200	27,300	636/565/495		3/8, 5/8
Convertible Surface Mounted 	093VEA2	35-7/16 x 7-7/8 x 19-5/16	9,600	10,900	268/243/219	31	1/4, 1/2
	123VEA2		12,300	13,600	325/268/244		
Floor Standing –Cased 	073 CEA4	42 x 8 x 25	7,500	8,500	300/265/229	60	1/4, 1/2
	093 CEA4		9,600	10,900	335/300/265		
	123 CEA4		12,300	13,600	371/335/300		
	153 CEA4		15,400	17,100	406/353/335		
	183 CFA4	52-15/16 x 8 x 25	19,100	21,500	565/494/424	75	3/8, 5/8
	243 CFA4		24,200	27,300	635/565/494		
Floor Standing – Uncased 	073 CEU4	38-1/2 x 7-15/16 x 25-3/16	7,500	8,500	300/265/229	46	1/4, 1/2
	093 CEU4		9,600	10,900	335/300/265		
	123 CEU4		12,300	13,600	371/335/300		
	153 CEU4		15,400	17,100	406/353/335		
	183 CFU4	49-7/16 x 7-1/2 x 25-3/16	19,100	21,500	565/494/424	58	3/8, 5/8
	243 CFU4		24,200	27,300	635/565/494		

¹All indoor units require 208–230V/60Hz/1Ph and an AWG18-2 communication cable.

²Model number shows nominal capacity and frame size designator.







³Nominal cooling capacity rating obtained with air entering the indoor unit at 80°F dry bulb (DB) and 67°F wet bulb (WB) and outdoor ambient conditions of 95°F dry bulb (DB) and 75°F wet bulb (WB).

Nominal heating capacity rating obtained with air entering the indoor unit at 70°F dry bulb (DB) and 60°F wet bulb (WB) and outdoor ambient conditions of 47°F dry bulb (DB) and 43°F wet bulb (WB).

⁴H/M/L = High/Medium/Low

Zone Controllers



Table 6: Summary Data—Zone Controllers

Zone Controller	Name	Model No.	Case Color	Max Wire Length (ft)	Description
	Simple Controller with mode selection	PQRCVCL0Q	Black	164	Allows control of indoor unit on/off, operation mode, fan speed, and temperature setpoint for up to 16 indoor units.
		PQRCVCL0QW	White		
	Simple Controller without mode selection	PQRCHCA0Q	Black	164	Allows control of indoor unit on/off, fan speed, and temperature setpoint for up to 16 indoor units.
		PQRCHCA0QW	White		
	LG Premium Controller	PREMTA000	Ivory	164	Allows control of indoor unit on/off, operation mode, occupied/unoccupied temperature setpoints, fan speed, and air flow direction for up to 16 indoor units. Programmable schedule with 5 events per day with control of occupied/unoccupied, on/off, mode, setpoints and fan speed. Advanced functions include two setpoint autochangeover, minimum difference between setpoints, setback, timed override, target energy consumption display, check energy display and master/slave.
	LG Programmable Thermostat	PREMTB10U	White	164	Allows control of indoor unit on/off, operation mode, occupied and unoccupied temperature setpoints, fan speed, and airflow direction for up to 16 indoor units. Programmable schedule with 5 events per day with control of occupied unoccupied, on/off, mode, setpoints and fan speed. Advanced functions include two setpoint autochangeover, minimum difference between setpoints, setback and timed override.
	Wireless Handheld	PQWRHQ0FDB	Ivory	----	Allows control of indoor unit on/off, operation mode, fan speed, and temperature setpoint.
	Wall-Mounted Remote Temperature Sensor	PQRSTA0	Ivory	50	Allows remote temperature measurement for cassette and ducted units.

Before specifying or placing an order, refer to the V-Net Network Solution Engineering Product Data Book and review the detailed technical data provided to fully understand the capabilities and limitations of these devices.

For information on controller compatibility refer to Table 11 - Indoor Unit Controls and Options.







Table 7: Summary Data—Zone Controller Communication Cables

Communication Cable	Name	Model No.	Wire Length (ft.)	Description
	Wired Remote Group Control Cable Assembly	PZCWRCG3	33	Required when grouping multiple indoor units with a single zone controller.
	Wired Remote/Group Control Extension Cable	PZCWRC1	33	Increases the distance between a remote controller and an indoor unit or between indoor units in a control group.

Before specifying or placing an order, refer to the V-Net Network Solution Engineering Product Data Book and review the detailed technical data provided to fully understand the capabilities and limitations of these devices.

For information on controller compatibility refer to Table 11 - Indoor Unit Controls and Options.

Table 8: Summary Data—Specialty Application Devices




Specialty Application Device	Name	Model No.	Connect to	Application	Binary Signals Input/Output	Description
	Simple Dry Contact	PQDSB1	Indoor Unit	On/Off, Run Status, Error Status	1/2	Enables the indoor unit to be controlled and monitored by third party controls using binary inputs and outputs.
	Dry Contact for Economizer, occupied/unoccupied	PQDSBC1		On/Off, Mode, Controller Lock, Power Save, Run Status, Error Status	2/2	
	Dry Contact Unit for 24V Thermostat	PDRYCB300		On/Off, Thermo On/Off, Mode, Fan Speed, Run Status, Error Status	---	Enables the indoor unit to be controlled and monitored by a third party thermostat or controller.
	Digital Output (DO) Kit	PQNFP00T0	Comm Bus	On/Off	0/1	One 25A DPST normally open relay. Used with central controller to control third party device manually or by schedule.
	I/O Module	PEXPMB000	AC Smart IV and ACP IV	Third party equipment control. Allows system expansion through Digital and Analog inputs and outputs.	---	3 Digital Inputs: Dry Contact input only 3 Digital Outputs: Max. 2A@30VAC/DC 4 Analog Outputs: 0 to 10 VDC, configurable; 0 to 20 mA, configurable 4 Universal Inputs individually configurable as analog or digital: Analog: Voltage. Current. Thermistor (NTC, PT, Ni) Digital for Dry Contact input only
	Auxiliary Heater Relay Kit	PRARH0	Indoor Unit	Third party supplemental heat control	0/1	Adds coordinated control of an external heater with normal heat pump operations.
	Auxiliary Two-Stage Heater Relay Kit	PRARH1				
	Power Distribution Indicator (PDI) Premium	PQNUD1S41	Comm Bus	Energy consumption monitoring	8 Watt Node Meters	Monitors total outdoor unit power consumption for up to eight systems, and distributes per indoor unit based on weighted calculation.
	Mode Selector Switch	PRDSBM	Outdoor Unit	Multi V Heat Pump Only	---	Locks outdoor unit into Heat, Cool, or Fan Mode.

Before specifying or placing an order, refer to the V-Net Network Solution Engineering Product Data Book and review the detailed technical data provided to fully understand the capabilities and limitations of these devices.

For information on controller compatibility refer to Table 11 - Indoor Unit Controls and Options.

Central Controllers


Table 9: Summary Data—Central Controllers (connect to the outdoor unit terminals Internet A, Internet B)

Central Controller	Name	Model No.	Devices per Controller	Systems per Comm Bus	Devices per Comm Bus	No. of Comm Bus Ports	Binary Signals Input/Output	Power, Conn	Description
	AC Smart IV	PACS4B000	128	16	128	1	2 DI / 2 DO	24 VAC	Monitors / operates indoor units through a touch screen. Manages up to 128 devices. Advanced functions include programmable schedules, temperature setpoint range lock, remote controller lock, run time limit, manual control and scheduling of digital output kit, peak/demand control, visual floor plan navigation, web access, operation and error history log, one digital input and two digital outputs for device interlocking and error e-mail notification.
	AC Ez	PQCSZ250S0	32	16	256	1	---	12 VDC, ODU	Provides for scheduling in addition to basic indoor unit control and monitoring.
	Advanced Control Platform IV (ACP IV)	PACP4B000	256	16	64	4	10/4	24 VAC	Provides for scheduling, remote controller lock, setpoint range limit, web access, peak/demand control, PDI integration, and AC Manager Plus integration advanced functionality in addition to basic unit control and monitoring.

Before specifying or placing an order, refer to the V-Net Network Solution Engineering Product Data Book and review the detailed technical data provided to fully understand the capabilities and limitations of these devices.

For information on controller compatibility refer to Table 11 - Indoor Unit Controls and Options.

Table 10: Summary Data—Integration Solutions (connect to outdoor unit terminals Internet A, Internet B)

Integration Solution	Name	Model No.	Devices per Controller	Systems per Comm Bus	Devices per Comm Bus	No. of Comm Bus Ports	Power	Binary Signals Input/Output	Description
	ACP IV BACnet® Gateway*	PQNFB17C1	256	16	256	4	24 VAC	10/4	Allow integration of LG equipment for control and monitoring by open protocol BACnet® and LonWorks® building automation and controls systems.*
	LonWorks® Gateway*	PLNWKB100	64	16	64	1	24 VAC	2/2	

Before specifying or placing an order, refer to the V-Net Network Solution Engineering Product Data Book and review the detailed technical data provided to fully understand the capabilities and limitations of these devices.

For information on controller compatibility refer to Table 11 - Indoor Unit Controls and Options.

* BACnet™ is a trademark of ASHRAE; LonWorks™ is a trademark of Echlelon Corporation.

GENERAL DATA



Indoor Units—Controls and Options

Table 11: Indoor Units—Controls and Options

Feature	Wall Mounted—Standard Finish	Wall Mounted—ART COOL™ Mirror	1-Way Cassette	2-Way Cassette	4-Way Cassette		Ducted High Static	Ducted Low Static	Ducted Low Static—Bottom Return	Vert.-Horiz. AHU (NU)	Vert.-Horiz. AHU (NK)	Ceiling Suspended	Convertible Surface Mount	Floor Mount—Cased	Floor Mount—Uncased
Nominal Chassis Size (MBh)	5–24	7–24	7–24	18–24	5–18	24–48	7–96	7–24	7–24	12–36	42–53	18–24	9–12	7–24	7–24
Airflow															
Air supply outlets	1	1	1	2	4	4	1	1	1	1	1	1	1	1	1
Airflow direction (left/right)	manual	auto										manual	manual		
Auto airflow direction (up/down)	√	√	√	√	√	√						√	√		
Fan speed (Heating mode)	3	3	4	4	4	4	3	3	3	3	3	3	3	3	3
Fan speed (Cooling mode)	4	4	5	5	5	5	3	3	3	3	3	4	4	3	3
Fan speed (fan mode)	3	3	4	4	4	4	3	3	3	3	3	3	3	3	3
Chaos swing (random louver swing)	√	√													
Chaos wind (random fan speed)	√	√	√	√	√	√						√	√		
Jet-cool (power cooling)	√	√	√	√	√	√						√	√		
Operation															
E.S.P. control			√	√	√	√	√	√	√	√	√				
High ceiling			√	√	√	√			√	√	√	√	√	√	√
Auto-restart after power restore	√	√	√	√	√	√	√	√	√	√	√	√	√	√	√
Hot start	√	√	√	√	√	√	√	√	√	√	√	√	√	√	√
Diagnostics	√	√	√	√	√	√	√	√	√	√	√	√	√	√	√
Auto changeover ¹	√	√	√	√	√	√	√	√	√	√	√	√	√	√	√
Auto operation ⁶	√	√	√	√	√	√	√	√							
Auto clean (coil dry)	√	√							√	√	√	√	√	√	√
Child lock	√	√	√	√	√	√	√	√	√	√	√	√	√	√	√
Dual thermistor control	√	√	√	√	√	√	√	√	√	√	√	√	√	√	√
Dual set-point control	√	√	√	√	√	√	√	√	√	√	√	√	√	√	√
Filter life display	√	√	√	√	√	√	√	√	√	√	√	√	√	√	√
Power consumption display (with PDI)	√	√	√	√	√	√	√	√				√	√		
Forced operation	√	√	√	√	√	√			√	√	√	√	√	√	√
Group control – Requires the use of one Group control cable kit (PZCWRG3) for every additional indoor unit	√	√	√	√	√	√	√	√	√	√	√	√	√	√	√
Timer (on/off)	√	√	√	√	√	√	√	√	√	√	√	√	√	√	√
Weekly schedule	√	√	√	√	√	√	√	√	√	√	√	√	√	√	√
Test operation mode	√	√	√	√	√	√	√	√							
Controllers															
Filter															
Plasma ³	0	√	0	0	0	0			√			√	√	√	√
Washable anti-fungal ²	√	√	√	√	√	√	√	√	0			0	0	0	0
7-day programmable controller	0	0	0	0	0	0	0	0	0	0	0	0	0	0	0
Simple controller w/mode	0	0	0	0	0	0	0	0	0	0	0	0	0	0	0
Simple controller w/o mode	0	0	0	0	0	0	0	0	0 ⁴	0	0	0	0	0 ⁴	0 ⁴
Wireless controller	0	0	0	0	0	0	0 ⁴	0 ⁴	√						
Others															
Condensate lift			√	√	√	√	√	√	√						
Ventilation air			√		√ ⁵	√ ⁵	√	√				√	√	√	
Casing	√	√	√	√	√	√									
Standard grille			√	√	√	√									
Auto elevation grille							0		0						
Suction grille									0						
Suction canvas										√	√				
Aux. heat kit															

¹For Heat Recovery systems only.

²Primary washable filters.

³Plasma filter kit accessories available separately, except for ArtCool Mirror which is included as standard.

⁴Requires 7-day programmable zone controller.

⁵Requires ventilation kit PTVK430 or PTVK410+PTVK420 (For TP, TN, TM frames)(Temperature, humidity, and volume limitations apply).

⁶Heat Pump systems only.

√ = Standard feature

0 = Unit option



PERFORMANCE DATA

"Performance Data" on page 26

"Unit Refrigerant Flow Diagrams" on page 44

"Outdoor Wiring Diagram" on page 157

PERFORMANCE DATA



Cooling Capacity— 3.0 Ton

Table 12a: ARUN036GS2 Heat Pump—Nominal Cooling Capacity

Combination Ratio (%)	Outdoor Air Temp (°F) DB	Indoor Air Temperature (°F) WB													
		57		61		64		67		70		73		76	
		MBh	PI	MBh	PI	MBh	PI	MBh	PI	MBh	PI	MBh	PI	MBh	PI
130	23	32.7	1.22	39.5	1.56	44.9	1.83	50.0	2.10	51.6	2.04	52.1	1.99	53.3	1.93
	25	32.7	1.24	39.5	1.58	44.9	1.85	50.0	2.12	51.6	2.05	52.1	2.00	53.3	1.95
	30	32.7	1.26	39.5	1.59	44.9	1.87	50.0	2.14	51.6	2.07	52.1	2.02	53.3	1.97
	35	32.7	1.27	39.5	1.61	44.9	1.88	50.0	2.15	51.6	2.09	52.1	2.04	53.3	1.99
	40	32.7	1.31	39.5	1.65	44.9	1.92	50.0	2.19	51.6	2.12	52.1	2.09	53.3	2.02
	45	32.7	1.32	39.5	1.66	44.9	1.93	50.0	2.21	51.6	2.14	52.1	2.10	53.3	2.04
	50	32.7	1.37	39.5	1.71	44.9	1.97	50.0	2.23	51.6	2.18	52.1	2.13	53.3	2.07
	55	32.7	1.39	39.5	1.74	44.9	2.02	50.0	2.25	50.8	2.19	51.6	2.13	52.5	2.10
	60	32.7	1.45	39.5	1.82	44.9	2.11	48.3	2.31	49.5	2.33	50.0	2.34	51.2	2.36
	65	32.7	1.48	39.5	1.88	44.9	2.26	47.4	2.44	48.7	2.46	49.1	2.47	50.4	2.49
	70	32.7	1.53	39.5	2.03	44.9	2.45	47.0	2.57	47.9	2.59	48.7	2.61	49.5	2.62
	75	32.7	1.68	39.5	2.23	44.9	2.70	46.2	2.74	47.0	2.76	47.9	2.77	48.7	2.79
	80	32.7	1.81	39.5	2.41	44.1	2.84	45.3	2.86	46.2	2.89	47.0	2.90	47.9	2.93
	85	32.7	2.10	39.5	2.79	42.8	3.10	43.7	3.13	44.9	3.15	45.3	3.17	46.6	3.20
	90	32.7	2.25	39.5	3.00	42.0	3.23	43.2	3.26	44.1	3.29	44.9	3.31	45.8	3.34
95	32.7	2.41	39.5	3.23	41.6	3.36	42.0	3.39	43.2	3.43	44.1	3.45	45.3	3.48	
100	32.7	2.58	39.5	3.46	40.7	3.50	41.6	3.53	42.8	3.56	43.2	3.58	44.5	3.61	
105	31.9	2.82	37.4	3.66	38.2	3.80	39.5	4.07	40.3	4.24	41.6	4.31	42.4	4.38	
110	29.4	2.88	34.8	3.73	35.7	3.94	36.9	4.38	37.8	4.51	40.3	4.68	41.1	4.78	
115	29.1	2.91	34.5	3.77	35.3	3.97	36.6	4.41	37.4	4.56	39.9	4.73	40.7	4.83	
120	23	30.1	1.11	36.7	1.42	41.6	1.65	46.2	1.92	50.7	2.09	51.1	2.07	52.4	1.99
	25	30.1	1.13	36.7	1.43	41.6	1.67	46.2	1.94	50.7	2.11	51.1	2.09	52.4	2.01
	30	30.1	1.15	36.7	1.45	41.6	1.69	46.2	1.96	50.7	2.12	51.1	2.11	52.4	2.02
	35	30.1	1.16	36.7	1.47	41.6	1.70	46.2	1.97	50.7	2.14	51.1	2.12	52.4	2.04
	40	30.1	1.20	36.7	1.50	41.6	1.74	46.2	2.01	50.7	2.17	51.1	2.16	52.4	2.07
	45	30.1	1.21	36.7	1.52	41.6	1.75	46.2	2.02	50.7	2.19	51.1	2.17	52.4	2.09
	50	30.1	1.25	36.7	1.56	41.6	1.80	46.2	2.05	50.7	2.22	51.1	2.18	52.4	2.12
	55	30.1	1.27	36.7	1.59	41.6	1.84	46.2	2.09	49.9	2.23	50.7	2.19	51.5	2.13
	60	30.1	1.33	36.7	1.66	41.6	1.92	46.2	2.18	48.6	2.32	49.1	2.33	49.9	2.34
	65	30.1	1.36	36.7	1.69	41.6	2.01	46.2	2.37	47.8	2.45	48.6	2.46	49.5	2.47
	70	29.8	1.44	36.3	1.88	41.2	2.26	45.7	2.66	46.5	2.68	47.3	2.69	48.2	2.71
	75	30.1	1.51	36.7	1.99	41.6	2.39	45.3	2.72	46.2	2.74	47.0	2.75	47.8	2.77
	80	30.1	1.62	36.7	2.14	41.6	2.58	44.5	2.85	45.3	2.87	46.2	2.89	47.0	2.91
	85	30.1	1.87	36.7	2.48	41.6	2.99	42.9	3.11	44.1	3.13	44.5	3.15	45.8	3.18
	90	30.1	2.01	36.7	2.66	41.2	3.21	42.5	3.24	43.3	3.27	44.1	3.29	44.9	3.31
95	30.1	2.15	36.7	2.86	40.8	3.34	41.2	3.37	42.5	3.40	43.3	3.42	44.1	3.45	
100	30.1	2.30	36.7	3.06	40.0	3.48	40.8	3.50	42.0	3.54	42.5	3.55	43.3	3.58	
105	28.9	2.53	34.2	3.37	36.7	3.68	38.8	4.05	39.6	4.21	40.8	4.28	41.6	4.35	
110	28.0	2.76	32.6	3.61	33.8	3.91	36.3	4.35	37.1	4.48	39.6	4.65	40.4	4.75	
115	27.8	2.79	32.2	3.64	33.4	3.95	35.9	4.39	36.7	4.53	39.2	4.70	40.0	4.80	
110	23	27.5	1.01	33.6	1.27	38.0	1.51	42.5	1.71	46.9	1.94	49.8	2.11	51.4	2.04
	25	27.5	1.02	33.6	1.29	38.0	1.52	42.5	1.73	46.9	1.96	49.8	2.13	51.4	2.06
	30	27.5	1.04	33.6	1.31	38.0	1.54	42.5	1.74	46.9	1.98	49.8	2.14	51.4	2.08
	35	27.5	1.06	33.6	1.32	38.0	1.56	42.5	1.76	46.9	1.99	49.8	2.16	51.4	2.09
	40	27.5	1.09	33.6	1.36	38.0	1.59	42.5	1.79	46.9	2.03	49.8	2.19	51.4	2.13
	45	27.5	1.11	33.6	1.37	38.0	1.61	42.5	1.81	46.9	2.04	49.8	2.21	51.4	2.14
	50	27.5	1.13	33.6	1.41	38.0	1.63	42.5	1.85	46.9	2.08	49.8	2.23	51.4	2.18
	55	27.5	1.16	33.6	1.44	38.0	1.66	42.5	1.89	46.9	2.12	49.8	2.24	50.6	2.19
	60	27.5	1.20	33.6	1.50	38.0	1.73	42.5	1.97	46.9	2.23	48.2	2.31	49.0	2.33
	65	27.5	1.23	33.6	1.53	38.0	1.77	42.5	2.08	46.9	2.42	47.3	2.44	48.6	2.46
	70	27.5	1.26	33.6	1.60	38.0	1.91	42.5	2.25	46.1	2.56	46.9	2.57	47.8	2.59
	75	27.5	1.34	33.6	1.76	38.0	2.10	42.5	2.48	45.3	2.72	45.7	2.73	46.9	2.75
	80	27.5	1.44	33.6	1.89	38.0	2.26	42.5	2.67	44.5	2.85	45.3	2.86	46.1	2.89
	85	27.5	1.66	33.6	2.18	38.0	2.62	42.5	3.09	43.3	3.11	43.7	3.13	44.5	3.15
	90	27.5	1.78	33.6	2.34	38.0	2.82	41.7	3.22	42.5	3.24	42.9	3.26	44.1	3.28
95	27.5	1.91	33.6	2.51	38.0	3.02	40.5	3.35	41.7	3.38	42.5	3.39	43.3	3.42	
100	27.5	2.04	33.6	2.70	38.0	3.25	40.1	3.48	40.9	3.51	41.7	3.53	42.5	3.55	
105	25.9	2.24	29.9	3.02	35.2	3.55	38.0	4.02	38.8	4.19	40.1	4.25	40.9	4.32	
110	25.1	2.48	28.3	3.25	32.4	4.12	35.6	4.32	36.4	4.46	38.8	4.62	39.7	4.72	
115	24.8	2.50	28.1	3.28	32.0	4.16	35.2	4.36	36.0	4.50	38.4	4.67	39.2	4.77	

Capacity rated using ISO 5151—Test Rating Standard for Non-Ducted Heat Pumps.

Cooling mode stable operation is ensured when the outdoor ambient dry-bulb temperature is between 23°F and 115°F.

Rapid cooling operation is stable at indoor temperatures up to 80°F DB.

Power Input (PI) in kW and includes compressor(s) and outdoor fan motor(s).

Rated with an equivalent piping length of 24.6 ft. and no change in elevation between the indoor and outdoor unit.

MBh = Net Capacity

R410A, 60 Hz

Due to differences in test method and procedures, capacity data values provided in these tables may differ from certified performance information published by AHRI or other standardized testing agencies. AHRI testing protocol sets the volume of air flowing over the coil at 444 CFM/ton and limits the number of indoor units connected to the system being tested. LG conducts capacity tests using airflow rates and limits the number of indoor units per system as stated in Table 4 (a and b) on pages 17–18, Table 5 on page 19, and Table 14 on page 56.



Table 12b: ARUN036GS2 Heat Pump—Nominal Cooling Capacity

Combination Ratio (%)	Outdoor Air Temp (°F) DB	Indoor Air Temperature (°F) WB													
		57		61		64		67		70		73		76	
		MBh	PI	MBh	PI	MBh	PI	MBh	PI	MBh	PI	MBh	PI	MBh	PI
100	23	25.2	0.78	30.6	1.02	34.4	1.18	38.2	1.24	42.8	1.61	45.5	1.74	49.3	1.98
	25	25.2	0.81	30.6	1.05	34.4	1.21	38.2	1.30	42.8	1.64	45.5	1.77	49.3	2.02
	30	25.2	0.84	30.6	1.09	34.4	1.24	38.2	1.36	42.8	1.67	45.5	1.80	49.3	2.05
	35	25.2	0.87	30.6	1.12	34.4	1.27	38.2	1.43	42.8	1.71	45.5	1.83	49.3	2.08
	40	25.2	0.93	30.6	1.18	34.4	1.33	38.2	1.55	42.8	1.77	45.5	1.89	49.3	2.14
	45	25.2	0.96	30.6	1.21	34.4	1.40	38.2	1.61	42.8	1.80	45.5	1.92	49.3	2.17
	50	25.2	1.03	30.6	1.27	34.4	1.46	38.2	1.66	42.8	1.86	45.5	2.00	49.3	2.21
	55	25.2	1.04	30.6	1.29	34.4	1.49	38.2	1.69	42.8	1.90	45.5	2.04	49.3	2.25
	60	25.2	1.09	30.6	1.35	34.4	1.56	38.2	1.77	42.8	1.98	45.5	2.13	48.1	2.31
	65	25.2	1.11	30.6	1.38	34.4	1.59	38.2	1.81	42.8	2.10	45.5	2.30	47.4	2.44
	70	25.2	1.13	30.6	1.41	34.4	1.67	38.2	1.96	42.8	2.27	45.5	2.49	46.6	2.57
	75	25.2	1.19	30.6	1.54	34.4	1.83	38.2	2.15	42.8	2.50	45.1	2.71	45.8	2.73
	80	25.2	1.27	30.6	1.65	34.4	1.97	38.2	2.32	42.8	2.70	44.3	2.84	45.1	2.86
	85	25.2	1.46	30.6	1.91	34.4	2.28	38.2	2.69	42.4	3.09	42.8	3.10	43.5	3.13
	90	25.2	1.57	30.6	2.05	34.4	2.45	38.2	2.89	41.6	3.22	42.0	3.24	42.8	3.26
95	25.2	1.67	30.6	2.19	34.4	2.62	38.2	3.10	40.9	3.35	41.6	3.37	42.4	3.39	
100	25.2	1.79	30.6	2.35	34.4	2.82	38.2	3.33	40.1	3.48	40.9	3.50	41.6	3.53	
105	25.2	2.02	29.0	2.73	32.9	3.22	36.7	3.72	37.4	3.81	39.3	3.88	40.1	4.00	
110	24.4	2.23	27.5	2.95	30.6	3.75	34.4	4.00	35.1	4.06	37.4	4.22	39.0	4.31	
115	24.2	2.25	27.2	2.97	30.2	3.78	34.0	4.04	34.8	4.10	37.1	4.25	38.5	4.35	
90	23	22.7	0.74	27.5	0.93	30.9	1.11	34.4	1.27	38.5	1.46	40.9	1.59	44.4	1.78
	25	22.7	0.77	27.5	0.95	30.9	1.14	34.4	1.30	38.5	1.48	40.9	1.62	44.4	1.80
	30	22.7	0.79	27.5	0.98	30.9	1.17	34.4	1.32	38.5	1.51	40.9	1.64	44.4	1.83
	35	22.7	0.82	27.5	1.01	30.9	1.19	34.4	1.35	38.5	1.54	40.9	1.67	44.4	1.85
	40	22.7	0.87	27.5	1.06	30.9	1.25	34.4	1.40	38.5	1.59	40.9	1.72	44.4	1.91
	45	22.7	0.90	27.5	1.09	30.9	1.27	34.4	1.43	38.5	1.62	40.9	1.75	44.4	1.93
	50	22.7	0.92	27.5	1.13	30.9	1.29	34.4	1.47	38.5	1.65	40.9	1.77	44.4	1.96
	55	22.7	0.94	27.5	1.15	30.9	1.32	34.4	1.50	38.5	1.68	40.9	1.81	44.4	2.00
	60	22.7	0.97	27.5	1.20	30.9	1.38	34.4	1.57	38.5	1.76	40.9	1.88	44.4	2.08
	65	22.7	0.99	27.5	1.22	30.9	1.41	34.4	1.60	38.5	1.79	40.9	1.96	44.4	2.23
	70	22.7	1.01	27.5	1.25	30.9	1.44	34.4	1.68	38.5	1.94	40.9	2.12	44.4	2.42
	75	22.7	1.04	27.5	1.33	30.9	1.58	34.4	1.84	38.5	2.13	40.9	2.34	44.4	2.66
	80	22.7	1.12	27.5	1.43	30.9	1.70	34.4	1.99	38.5	2.30	40.9	2.52	44.0	2.84
	85	22.7	1.28	27.5	1.65	30.9	1.96	34.4	2.30	38.5	2.66	40.9	2.92	42.6	3.10
	90	22.7	1.37	27.5	1.77	30.9	2.10	34.4	2.47	38.5	2.86	40.9	3.14	41.9	3.23
95	22.7	1.46	27.5	1.89	30.9	2.25	34.4	2.65	38.5	3.07	40.6	3.34	41.3	3.36	
100	22.7	1.56	27.5	2.02	30.9	2.41	34.4	2.84	38.5	3.25	39.9	3.47	40.6	3.49	
105	22.7	1.70	27.5	2.20	30.6	2.62	34.0	3.07	37.8	3.54	38.5	3.61	39.2	3.61	
110	22.7	1.72	27.5	2.23	30.3	2.65	33.7	3.10	36.1	3.58	37.8	3.63	38.5	3.63	
115	22.7	1.73	27.5	2.24	30.3	2.67	33.7	3.13	36.1	3.61	37.8	3.66	38.5	3.66	
80	23	20.2	0.65	24.4	0.83	27.5	0.98	30.6	1.14	34.2	1.27	36.4	1.39	39.4	1.54
	25	20.2	0.67	24.4	0.85	27.5	1.01	30.6	1.16	34.2	1.30	36.4	1.41	39.4	1.56
	30	20.2	0.69	24.4	0.87	27.5	1.03	30.6	1.18	34.2	1.32	36.4	1.43	39.4	1.59
	35	20.2	0.72	24.4	0.89	27.5	1.05	30.6	1.21	34.2	1.34	36.4	1.45	39.4	1.61
	40	20.2	0.76	24.4	0.94	27.5	1.10	30.6	1.25	34.2	1.39	36.4	1.50	39.4	1.65
	45	20.2	0.78	24.4	0.96	27.5	1.12	30.6	1.27	34.2	1.41	36.4	1.52	39.4	1.68
	50	20.2	0.82	24.4	0.99	27.5	1.14	30.6	1.29	34.2	1.44	36.4	1.54	39.4	1.71
	55	20.2	0.83	24.4	1.02	27.5	1.16	30.6	1.31	34.2	1.47	36.4	1.58	39.4	1.74
	60	20.2	0.86	24.4	1.05	27.5	1.21	30.6	1.37	34.2	1.53	36.4	1.64	39.4	1.82
	65	20.2	0.88	24.4	1.08	27.5	1.23	30.6	1.40	34.2	1.57	36.4	1.68	39.4	1.87
	70	20.2	0.90	24.4	1.10	27.5	1.26	30.6	1.43	34.2	1.64	36.4	1.79	39.4	2.03
	75	20.2	0.92	24.4	1.14	27.5	1.35	30.6	1.57	34.2	1.80	36.4	1.97	39.4	2.23
	80	20.2	0.97	24.4	1.23	27.5	1.45	30.6	1.68	34.2	1.94	36.4	2.12	39.4	2.40
	85	20.2	1.10	24.4	1.41	27.5	1.67	30.6	1.94	34.2	2.24	36.4	2.45	39.4	2.79
	90	20.2	1.18	24.4	1.51	27.5	1.78	30.6	2.08	34.2	2.41	36.4	2.63	39.4	3.00
95	20.2	1.26	24.4	1.62	27.5	1.91	30.6	2.23	34.2	2.58	36.4	2.83	39.4	3.22	
100	20.2	1.34	24.4	1.73	27.5	2.05	30.6	2.39	34.2	2.77	36.4	3.03	39.4	3.45	
105	20.2	1.45	24.4	1.88	27.5	2.21	30.6	2.59	34.2	2.99	36.4	3.29	38.8	3.64	
110	20.2	1.47	24.4	1.90	27.5	2.23	30.6	2.61	34.2	3.02	36.4	3.31	38.8	3.66	
115	20.2	1.49	24.4	1.92	27.5	2.25	30.6	2.64	34.2	3.04	36.4	3.33	38.8	3.70	

Capacity rated using ISO 5151—Test Rating Standard for Non-Ducted Heat Pumps.
 Cooling mode stable operation is ensured when the outdoor ambient dry-bulb temperature is between 23°F and 115°F.
 Rapid cooling operation is stable at indoor temperatures up to 80°F DB.
 Power Input (PI) in kW and includes compressor(s) and outdoor fan motor(s).
 Rated with an equivalent piping length of 24.6 ft. and no change in elevation between the indoor and outdoor unit.
 MBh = Net Capacity
 R410A, 60 Hz

Due to differences in test method and procedures, capacity data values provided in these tables may differ from certified performance information published by AHRI or other standardized testing agencies. AHRI testing protocol sets the volume of air flowing over the coil at 444 CFM/ton and limits the number of indoor units connected to the system being tested. LG conducts capacity tests using airflow rates and limits the number of indoor units per system as stated in Table 4 (a and b) on pages 17–18, Table 5 on page 19, and Table 14 on page 56.

MULTI V
MINI
HEAT PUMP CONDENSING UNIT ENGINEERING MANUAL

PERFORMANCE DATA



Cooling Capacity—3.0 Ton

Table 12c: ARUN036GS2 Heat Pump—Nominal Cooling Capacity

Combination Ratio (%)	Outdoor Air Temp (°F) DB	Indoor Air Temperature (°F) WB													
		57		61		64		67		70		73		76	
		MBh	PI	MBh	PI	MBh	PI	MBh	PI	MBh	PI	MBh	PI	MBh	PI
70	23	17.6	0.59	21.4	0.74	24.1	0.85	26.7	0.98	29.9	1.11	31.8	1.19	34.5	1.34
	25	17.6	0.61	21.4	0.76	24.1	0.87	26.7	1.00	29.9	1.13	31.8	1.21	34.5	1.35
	30	17.6	0.63	21.4	0.78	24.1	0.89	26.7	1.02	29.9	1.15	31.8	1.22	34.5	1.37
	35	17.6	0.65	21.4	0.80	24.1	0.91	26.7	1.04	29.9	1.17	31.8	1.24	34.5	1.39
	40	17.6	0.69	21.4	0.84	24.1	0.95	26.7	1.08	29.9	1.21	31.8	1.28	34.5	1.43
	45	17.6	0.71	21.4	0.85	24.1	0.96	26.7	1.09	29.9	1.22	31.8	1.30	34.5	1.45
	50	17.6	0.72	21.4	0.87	24.1	0.99	26.7	1.11	29.9	1.24	31.8	1.33	34.5	1.46
	55	17.6	0.73	21.4	0.88	24.1	1.00	26.7	1.13	29.9	1.27	31.8	1.36	34.5	1.49
	60	17.6	0.76	21.4	0.92	24.1	1.04	26.7	1.18	29.9	1.32	31.8	1.41	34.5	1.56
	65	17.6	0.77	21.4	0.94	24.1	1.07	26.7	1.20	29.9	1.34	31.8	1.44	34.5	1.59
	70	17.6	0.79	21.4	0.95	24.1	1.09	26.7	1.23	29.9	1.38	31.8	1.48	34.5	1.67
	75	17.6	0.80	21.4	0.98	24.1	1.13	26.7	1.31	29.9	1.49	31.8	1.63	34.5	1.84
	80	17.6	0.83	21.4	1.04	24.1	1.22	26.7	1.41	29.9	1.61	31.8	1.75	34.5	1.98
	85	17.6	0.95	21.4	1.19	24.1	1.40	26.7	1.62	29.9	1.85	31.8	2.02	34.5	2.28
	90	17.6	1.01	21.4	1.28	24.1	1.49	26.7	1.73	29.9	1.99	31.8	2.17	34.5	2.45
95	17.6	1.08	21.4	1.36	24.1	1.60	26.7	1.86	29.9	2.13	31.8	2.32	34.5	2.64	
100	17.6	1.15	21.4	1.45	24.1	1.71	26.7	1.98	29.9	2.28	31.8	2.49	34.5	2.82	
105	17.6	1.24	21.4	1.56	24.1	1.84	26.7	2.13	29.9	2.47	31.8	2.69	34.5	3.04	
110	17.6	1.26	21.4	1.58	24.1	1.86	26.7	2.15	29.9	2.49	31.8	2.71	34.5	3.06	
115	17.6	1.27	21.4	1.59	24.1	1.87	26.7	2.17	29.9	2.51	31.8	2.73	34.5	3.09	
60	23	15.1	0.50	18.3	0.62	20.6	0.71	22.9	0.82	25.7	0.92	27.3	0.98	29.6	1.10
	25	15.1	0.51	18.3	0.64	20.6	0.73	22.9	0.83	25.7	0.94	27.3	1.00	29.6	1.12
	30	15.1	0.53	18.3	0.65	20.6	0.74	22.9	0.85	25.7	0.95	27.3	1.01	29.6	1.13
	35	15.1	0.56	18.3	0.68	20.6	0.77	22.9	0.88	25.7	0.98	27.3	1.04	29.6	1.16
	40	15.1	0.57	18.3	0.70	20.6	0.79	22.9	0.89	25.7	1.00	27.3	1.06	29.6	1.18
	45	15.1	0.57	18.3	0.70	20.6	0.79	22.9	0.89	25.7	1.00	27.3	1.06	29.6	1.18
	50	15.1	0.59	18.3	0.71	20.6	0.80	22.9	0.91	25.7	1.01	27.3	1.08	29.6	1.19
	55	15.1	0.60	18.3	0.72	20.6	0.82	22.9	0.92	25.7	1.03	27.3	1.10	29.6	1.22
	60	15.1	0.62	18.3	0.75	20.6	0.85	22.9	0.96	25.7	1.08	27.3	1.15	29.6	1.27
	65	15.1	0.63	18.3	0.76	20.6	0.87	22.9	0.98	25.7	1.10	27.3	1.18	29.6	1.30
	70	15.1	0.64	18.3	0.78	20.6	0.89	22.9	1.00	25.7	1.12	27.3	1.21	29.6	1.36
	75	15.1	0.66	18.3	0.80	20.6	0.92	22.9	1.07	25.7	1.22	27.3	1.33	29.6	1.50
	80	15.1	0.68	18.3	0.85	20.6	0.99	22.9	1.15	25.7	1.31	27.3	1.43	29.6	1.61
	85	15.1	0.82	18.3	1.04	20.6	1.22	22.9	1.41	25.7	1.62	27.3	1.77	29.6	2.00
	90	15.1	0.82	18.3	1.04	20.6	1.22	22.9	1.41	25.7	1.62	27.3	1.77	29.6	2.00
95	15.1	0.88	18.3	1.11	20.6	1.30	22.9	1.51	25.7	1.74	27.3	1.89	29.6	2.15	
100	15.1	0.94	18.3	1.18	20.6	1.39	22.9	1.62	25.7	1.86	27.3	2.03	29.6	2.30	
105	15.1	1.01	18.3	1.27	20.6	1.50	22.9	1.74	25.7	2.01	27.3	2.19	29.6	2.48	
110	15.1	1.03	18.3	1.29	20.6	1.51	22.9	1.75	25.7	2.03	27.3	2.21	29.6	2.49	
115	15.1	1.04	18.3	1.30	20.6	1.52	22.9	1.77	25.7	2.04	27.3	2.24	29.6	2.52	
50	23	12.6	0.39	15.3	0.48	17.2	0.55	19.1	0.64	21.4	0.72	22.7	0.77	24.6	0.87
	25	12.6	0.40	15.3	0.49	17.2	0.57	19.1	0.65	21.4	0.74	22.7	0.78	24.6	0.88
	30	12.6	0.41	15.3	0.51	17.2	0.58	19.1	0.66	21.4	0.75	22.7	0.80	24.6	0.89
	35	12.6	0.42	15.3	0.52	17.2	0.59	19.1	0.68	21.4	0.76	22.7	0.81	24.6	0.90
	40	12.6	0.45	15.3	0.54	17.2	0.61	19.1	0.70	21.4	0.78	22.7	0.83	24.6	0.93
	45	12.6	0.46	15.3	0.55	17.2	0.63	19.1	0.71	21.4	0.80	22.7	0.84	24.6	0.94
	50	12.6	0.47	15.3	0.56	17.2	0.64	19.1	0.72	21.4	0.81	22.7	0.86	24.6	0.95
	55	12.6	0.48	15.3	0.57	17.2	0.65	19.1	0.74	21.4	0.82	22.7	0.88	24.6	0.97
	60	12.6	0.49	15.3	0.60	17.2	0.68	19.1	0.77	21.4	0.86	22.7	0.92	24.6	1.01
	65	12.6	0.50	15.3	0.61	17.2	0.69	19.1	0.78	21.4	0.87	22.7	0.94	24.6	1.03
	70	12.6	0.51	15.3	0.62	17.2	0.71	19.1	0.80	21.4	0.89	22.7	0.96	24.6	1.08
	75	12.6	0.52	15.3	0.64	17.2	0.74	19.1	0.85	21.4	0.97	22.7	1.06	24.6	1.19
	80	12.6	0.54	15.3	0.68	17.2	0.79	19.1	0.91	21.4	1.05	22.7	1.14	24.6	1.28
	85	12.6	0.66	15.3	0.83	17.2	0.97	19.1	1.12	21.4	1.29	22.7	1.41	24.6	1.59
	90	12.6	0.66	15.3	0.83	17.2	0.97	19.1	1.12	21.4	1.29	22.7	1.41	24.6	1.59
95	12.6	0.70	15.3	0.89	17.2	1.04	19.1	1.21	21.4	1.38	22.7	1.51	24.6	1.71	
100	12.6	0.75	15.3	0.94	17.2	1.11	19.1	1.29	21.4	1.48	22.7	1.62	24.6	1.84	
105	12.6	0.81	15.3	1.01	17.2	1.19	19.1	1.39	21.4	1.60	22.7	1.75	24.6	1.98	
110	12.6	0.82	15.3	1.02	17.2	1.21	19.1	1.40	21.4	1.62	22.7	1.76	24.6	1.99	
115	12.6	0.83	15.3	1.03	17.2	1.22	19.1	1.41	21.4	1.63	22.7	1.63	24.6	2.01	

Capacity rated using ISO 5151—Test Rating Standard for Non-Ducted Heat Pumps.
 Cooling mode stable operation is ensured when the outdoor ambient dry-bulb temperature is between 23°F and 115°F.
 Rapid cooling operation is stable at indoor temperatures up to 80°F DB.
 Power Input (PI) in kW and includes compressor(s) and outdoor fan motor(s).
 Rated with an equivalent piping length of 24.6 ft. and no change in elevation between the indoor and outdoor unit.
 MBh = Net Capacity
 R410A, 60 Hz

Due to differences in test method and procedures, capacity data values provided in these tables may differ from certified performance information published by AHRI or other standardized testing agencies. AHRI testing protocol sets the volume of air flowing over the coil at 444 CFM/ton and limits the number of indoor units connected to the system being tested. LG conducts capacity tests using airflow rates and limits the number of indoor units per system as stated in Table 4 (a and b) on pages 17–18, Table 5 on page 19, and Table 14 on page 56.



Table 13a: ARUN047GS2 Heat Pump—Nominal Cooling Capacity

Combination Ratio (%)	Outdoor Air Temp (°F) DB	Indoor Air Temperature (°F) WB													
		57		61		64		67		70		73		76	
		MBh	PI	MBh	PI	MBh	PI	MBh	PI	MBh	PI	MBh	PI	MBh	PI
130	23	41.0	1.67	49.4	2.14	56.2	2.51	62.5	2.88	64.6	2.79	65.1	2.72	66.7	2.65
	25	41.0	1.70	49.4	2.16	56.2	2.54	62.5	2.91	64.6	2.81	65.1	2.74	66.7	2.67
	30	41.0	1.72	49.4	2.19	56.2	2.56	62.5	2.93	64.6	2.84	65.1	2.77	66.7	2.70
	35	41.0	1.74	49.4	2.21	56.2	2.58	62.5	2.95	64.6	2.86	65.1	2.79	66.7	2.72
	40	41.0	1.79	49.4	2.26	56.2	2.63	62.5	3.00	64.6	2.91	65.1	2.86	66.7	2.77
	45	41.0	1.81	49.4	2.28	56.2	2.65	62.5	3.02	64.6	2.93	65.1	2.88	66.7	2.79
	50	41.0	1.87	49.4	2.34	56.2	2.71	62.5	3.06	64.6	2.99	65.1	2.92	66.7	2.84
	55	41.0	1.91	49.4	2.39	56.2	2.76	62.5	3.08	63.6	3.00	64.6	2.93	65.7	2.87
	60	41.0	1.99	49.4	2.50	56.2	2.89	60.4	3.17	62.0	3.20	62.5	3.21	64.1	3.24
	65	41.0	2.03	49.4	2.57	56.2	3.10	59.4	3.35	60.9	3.37	61.5	3.39	63.0	3.42
	70	41.0	2.10	49.4	2.78	56.2	3.36	58.8	3.52	59.9	3.55	60.9	3.57	62.0	3.60
	75	41.0	2.31	49.4	3.06	56.2	3.70	57.8	3.75	58.8	3.78	59.9	3.80	60.9	3.83
	80	41.0	2.49	49.4	3.30	55.2	3.90	56.7	3.93	57.8	3.96	58.8	3.98	59.9	4.01
	85	41.0	2.87	49.4	3.83	53.6	4.25	54.6	4.29	56.2	4.32	56.7	4.35	58.3	4.39
	90	41.0	3.08	49.4	4.11	52.5	4.43	54.1	4.47	55.2	4.51	56.2	4.53	57.3	4.57
	95	41.0	3.30	49.4	4.42	52.0	4.61	52.5	4.65	54.1	4.70	55.2	4.73	56.7	4.76
100	41.0	3.54	49.4	4.75	51.0	4.79	52.0	4.84	53.6	4.88	54.1	4.90	55.7	4.95	
105	39.9	3.86	46.8	5.02	47.8	5.21	49.4	5.58	50.4	5.81	52.0	5.91	53.1	6.00	
110	36.8	3.95	43.6	5.12	44.7	5.40	46.2	6.00	47.3	6.19	50.4	6.42	51.5	6.56	
115	36.4	3.99	43.2	5.17	44.2	5.44	45.8	6.05	46.8	6.25	49.9	6.48	51.0	6.62	
120	23	37.7	1.53	45.9	1.94	52.1	2.27	57.8	2.63	63.4	2.87	64.0	2.84	65.5	2.73
	25	37.7	1.55	45.9	1.96	52.1	2.29	57.8	2.66	63.4	2.89	64.0	2.87	65.5	2.75
	30	37.7	1.57	45.9	1.99	52.1	2.31	57.8	2.68	63.4	2.91	64.0	2.89	65.5	2.77
	35	37.7	1.59	45.9	2.01	52.1	2.33	57.8	2.70	63.4	2.94	64.0	2.91	65.5	2.80
	40	37.7	1.64	45.9	2.06	52.1	2.38	57.8	2.75	63.4	2.98	64.0	2.96	65.5	2.84
	45	37.7	1.66	45.9	2.08	52.1	2.40	57.8	2.77	63.4	3.00	64.0	2.98	65.5	2.87
	50	37.7	1.71	45.9	2.14	52.1	2.47	57.8	2.81	63.4	3.05	64.0	2.99	65.5	2.91
	55	37.7	1.75	45.9	2.18	52.1	2.52	57.8	2.87	62.4	3.06	63.4	3.00	64.5	2.92
	60	37.7	1.82	45.9	2.27	52.1	2.63	57.8	3.00	60.9	3.18	61.4	3.19	62.4	3.21
	65	37.7	1.86	45.9	2.32	52.1	2.75	57.8	3.25	59.8	3.35	60.9	3.37	61.9	3.39
	70	37.3	1.98	45.5	2.57	51.6	3.09	57.2	3.64	58.2	3.67	59.2	3.69	60.3	3.71
	75	37.7	2.07	45.9	2.73	52.1	3.28	56.7	3.73	57.8	3.75	58.8	3.77	59.8	3.80
	80	37.7	2.23	45.9	2.94	52.1	3.53	55.7	3.90	56.7	3.94	57.8	3.96	58.8	3.99
	85	37.7	2.56	45.9	3.40	52.1	4.10	53.6	4.26	55.2	4.29	55.7	4.32	57.3	4.35
	90	37.7	2.75	45.9	3.65	51.6	4.41	53.1	4.44	54.2	4.48	55.2	4.50	56.2	4.54
	95	37.7	2.95	45.9	3.92	51.1	4.58	51.6	4.62	53.1	4.66	54.2	4.69	55.2	4.73
100	37.7	3.16	45.9	4.20	50.0	4.76	51.1	4.80	52.6	4.85	53.1	4.87	54.2	4.90	
105	36.1	3.47	42.8	4.62	45.9	5.04	48.5	5.55	49.5	5.78	51.1	5.87	52.1	5.96	
110	35.1	3.79	40.8	4.95	42.3	5.36	45.4	5.96	46.4	6.15	49.5	6.38	50.6	6.52	
115	34.7	3.82	40.3	4.99	41.8	5.41	44.9	6.02	45.9	6.20	49.0	6.44	50.0	6.58	
110	23	34.4	1.38	42.0	1.75	47.6	2.07	53.2	2.34	58.7	2.66	62.3	2.89	64.3	2.80
	25	34.4	1.40	42.0	1.77	47.6	2.09	53.2	2.37	58.7	2.69	62.3	2.92	64.3	2.82
	30	34.4	1.42	42.0	1.79	47.6	2.11	53.2	2.39	58.7	2.71	62.3	2.94	64.3	2.85
	35	34.4	1.45	42.0	1.81	47.6	2.14	53.2	2.41	58.7	2.73	62.3	2.96	64.3	2.87
	40	34.4	1.49	42.0	1.86	47.6	2.18	53.2	2.46	58.7	2.78	62.3	3.01	64.3	2.92
	45	34.4	1.52	42.0	1.88	47.6	2.20	53.2	2.48	58.7	2.80	62.3	3.03	64.3	2.94
	50	34.4	1.55	42.0	1.94	47.6	2.23	53.2	2.54	58.7	2.85	62.3	3.06	64.3	2.99
	55	34.4	1.59	42.0	1.98	47.6	2.28	53.2	2.59	58.7	2.91	62.3	3.07	63.3	3.00
	60	34.4	1.65	42.0	2.06	47.6	2.38	53.2	2.71	58.7	3.06	60.3	3.17	61.3	3.19
	65	34.4	1.69	42.0	2.10	47.6	2.43	53.2	2.85	58.7	3.32	59.2	3.35	60.8	3.37
	70	34.4	1.73	42.0	2.19	47.6	2.62	53.2	3.09	57.7	3.51	58.7	3.52	59.8	3.55
	75	34.4	1.84	42.0	2.41	47.6	2.88	53.2	3.40	56.7	3.73	57.2	3.75	58.7	3.77
	80	34.4	1.98	42.0	2.59	47.6	3.10	53.2	3.67	55.7	3.91	56.7	3.93	57.7	3.96
	85	34.4	2.27	42.0	2.99	47.6	3.59	53.2	4.24	54.2	4.27	54.7	4.29	55.7	4.32
	90	34.4	2.44	42.0	3.21	47.6	3.86	52.2	4.41	53.2	4.45	53.7	4.47	55.2	4.50
	95	34.4	2.61	42.0	3.45	47.6	4.15	50.6	4.59	52.2	4.63	53.2	4.65	54.2	4.69
100	34.4	2.79	42.0	3.70	47.6	4.45	50.1	4.77	51.1	4.81	52.2	4.84	53.2	4.87	
105	32.4	3.08	37.5	4.13	44.1	4.87	47.6	5.51	48.6	5.74	50.1	5.83	51.1	5.93	
110	31.4	3.40	35.4	4.46	40.5	5.65	44.6	5.93	45.6	6.11	48.6	6.34	49.6	6.48	
115	31.1	3.43	35.1	4.50	40.1	5.70	44.1	5.98	45.1	6.16	48.1	6.40	49.1	6.54	

Capacity rated using ISO 5151—Test Rating Standard for Non-Ducted Heat Pumps.
Cooling mode stable operation is ensured when the outdoor ambient dry-bulb temperature is between 23°F and 115°F.
Rapid cooling operation is stable at indoor temperatures up to 80°F DB.
Power Input (PI) in kW and includes compressor(s) and outdoor fan motor(s).
Rated with an equivalent piping length of 24.6 ft. and no change in elevation between the indoor and outdoor unit.
MBh = Net Capacity
R410A, 60 Hz

Due to differences in test method and procedures, capacity data values provided in these tables may differ from certified performance information published by AHRI or other standardized testing agencies. AHRI testing protocol sets the volume of air flowing over the coil at 444 CFM/ton and limits the number of indoor units connected to the system being tested. LG conducts capacity tests using airflow rates and limits the number of indoor units per system as stated in Table 4 (a and b) on pages 17–18, Table 5 on page 19, and Table 14 on page 56.

PERFORMANCE DATA



Cooling Capacity—4.0 Ton

Table 13b: ARUN047GS2 Heat Pump—Nominal Cooling Capacity

Combination Ratio (%)	Outdoor Air Temp (°F) DB	Indoor Air Temperature (°F) WB													
		57		61		64		67		70		73		76	
		MBh	PI	MBh	PI	MBh	PI	MBh	PI	MBh	PI	MBh	PI	MBh	PI
100	23	31.5	1.06	38.2	1.40	43.0	1.62	47.8	1.70	53.5	2.21	56.9	2.38	61.7	2.72
	25	31.5	1.11	38.2	1.45	43.0	1.66	47.8	1.79	53.5	2.25	56.9	2.42	61.7	2.76
	30	31.5	1.15	38.2	1.49	43.0	1.70	47.8	1.87	53.5	2.30	56.9	2.47	61.7	2.81
	35	31.5	1.19	38.2	1.53	43.0	1.74	47.8	1.96	53.5	2.34	56.9	2.51	61.7	2.85
	40	31.5	1.28	38.2	1.62	43.0	1.83	47.8	2.13	53.5	2.42	56.9	2.59	61.7	2.93
	45	31.5	1.32	38.2	1.66	43.0	1.91	47.8	2.21	53.5	2.47	56.9	2.64	61.7	2.98
	50	31.5	1.41	38.2	1.74	43.0	2.00	47.8	2.27	53.5	2.55	56.9	2.74	61.7	3.03
	55	31.5	1.43	38.2	1.77	43.0	2.04	47.8	2.32	53.5	2.61	56.9	2.80	61.7	3.09
	60	31.5	1.49	38.2	1.85	43.0	2.13	47.8	2.42	53.5	2.72	56.9	2.92	60.2	3.17
	65	31.5	1.52	38.2	1.89	43.0	2.18	47.8	2.48	53.5	2.87	56.9	3.15	59.3	3.34
	70	31.5	1.55	38.2	1.93	43.0	2.28	47.8	2.68	53.5	3.11	56.9	3.41	58.3	3.52
	75	31.5	1.63	38.2	2.11	43.0	2.51	47.8	2.95	53.5	3.43	56.4	3.72	57.4	3.75
	80	31.5	1.75	38.2	2.26	43.0	2.70	47.8	3.18	53.5	3.70	55.4	3.90	56.4	3.92
	85	31.5	2.00	38.2	2.61	43.0	3.12	47.8	3.68	53.1	4.24	53.5	4.25	54.5	4.28
	90	31.5	2.15	38.2	2.80	43.0	3.35	47.8	3.96	52.1	4.42	52.6	4.44	53.5	4.47
	95	31.5	2.29	38.2	3.00	43.0	3.60	47.8	4.25	51.1	4.59	52.1	4.62	53.1	4.65
	100	31.5	2.46	38.2	3.22	43.0	3.86	47.8	4.56	50.2	4.77	51.1	4.80	52.1	4.83
	105	31.5	2.76	36.3	3.74	41.1	4.42	45.9	5.10	46.8	5.23	49.2	5.31	50.2	5.48
110	30.6	3.06	34.4	4.04	38.2	5.14	43.0	5.48	44.0	5.57	46.8	5.78	48.8	5.91	
115	30.3	3.09	34.0	4.07	37.8	5.19	42.6	5.53	43.5	5.62	46.4	5.83	48.2	5.96	
90	23	28.4	1.02	34.4	1.27	38.7	1.53	43.0	1.74	48.2	2.00	51.2	2.18	55.5	2.43
	25	28.4	1.05	34.4	1.31	38.7	1.56	43.0	1.78	48.2	2.03	51.2	2.22	55.5	2.47
	30	28.4	1.09	34.4	1.34	38.7	1.60	43.0	1.82	48.2	2.07	51.2	2.25	55.5	2.51
	35	28.4	1.13	34.4	1.38	38.7	1.63	43.0	1.85	48.2	2.11	51.2	2.29	55.5	2.54
	40	28.4	1.20	34.4	1.45	38.7	1.71	43.0	1.93	48.2	2.18	51.2	2.36	55.5	2.62
	45	28.4	1.24	34.4	1.49	38.7	1.74	43.0	1.96	48.2	2.22	51.2	2.40	55.5	2.65
	50	28.4	1.26	34.4	1.55	38.7	1.77	43.0	2.01	48.2	2.26	51.2	2.43	55.5	2.68
	55	28.4	1.28	34.4	1.58	38.7	1.81	43.0	2.05	48.2	2.31	51.2	2.48	55.5	2.74
	60	28.4	1.33	34.4	1.64	38.7	1.89	43.0	2.15	48.2	2.41	51.2	2.58	55.5	2.86
	65	28.4	1.36	34.4	1.68	38.7	1.93	43.0	2.19	48.2	2.46	51.2	2.69	55.5	3.06
	70	28.4	1.39	34.4	1.72	38.7	1.98	43.0	2.30	48.2	2.66	51.2	2.91	55.5	3.31
	75	28.4	1.43	34.4	1.83	38.7	2.17	43.0	2.53	48.2	2.93	51.2	3.21	55.5	3.65
	80	28.4	1.53	34.4	1.97	38.7	2.33	43.0	2.73	48.2	3.16	51.2	3.46	55.1	3.89
	85	28.4	1.75	34.4	2.26	38.7	2.69	43.0	3.15	48.2	3.65	51.2	4.01	53.3	4.25
	90	28.4	1.87	34.4	2.42	38.7	2.88	43.0	3.38	48.2	3.93	51.2	4.31	52.5	4.43
	95	28.4	2.00	34.4	2.59	38.7	3.09	43.0	3.63	48.2	4.22	50.8	4.58	51.6	4.61
	100	28.4	2.14	34.4	2.77	38.7	3.31	43.0	3.89	48.2	4.45	49.9	4.76	50.8	4.79
	105	28.4	2.32	34.4	3.01	38.3	3.60	42.6	4.21	47.3	4.86	48.2	4.95	49.0	4.95
110	28.4	2.36	34.4	3.05	37.9	3.63	42.2	4.25	45.2	4.90	47.3	4.98	48.2	4.98	
115	28.4	2.38	34.4	3.08	37.9	3.66	42.2	4.29	45.2	4.94	47.3	5.02	48.2	5.02	
80	23	25.2	0.89	30.6	1.13	34.4	1.35	38.2	1.56	42.8	1.75	45.5	1.90	49.3	2.11
	25	25.2	0.92	30.6	1.16	34.4	1.38	38.2	1.59	42.8	1.78	45.5	1.93	49.3	2.14
	30	25.2	0.95	30.6	1.19	34.4	1.41	38.2	1.62	42.8	1.81	45.5	1.96	49.3	2.18
	35	25.2	0.98	30.6	1.23	34.4	1.44	38.2	1.65	42.8	1.84	45.5	1.99	49.3	2.21
	40	25.2	1.04	30.6	1.29	34.4	1.50	38.2	1.72	42.8	1.90	45.5	2.05	49.3	2.27
	45	25.2	1.07	30.6	1.32	34.4	1.53	38.2	1.75	42.8	1.93	45.5	2.08	49.3	2.30
	50	25.2	1.12	30.6	1.36	34.4	1.56	38.2	1.76	42.8	1.98	45.5	2.12	49.3	2.34
	55	25.2	1.14	30.6	1.39	34.4	1.59	38.2	1.80	42.8	2.01	45.5	2.16	49.3	2.39
	60	25.2	1.18	30.6	1.45	34.4	1.66	38.2	1.88	42.8	2.10	45.5	2.25	49.3	2.49
	65	25.2	1.21	30.6	1.48	34.4	1.69	38.2	1.92	42.8	2.15	45.5	2.30	49.3	2.57
	70	25.2	1.23	30.6	1.50	34.4	1.73	38.2	1.96	42.8	2.25	45.5	2.45	49.3	2.78
	75	25.2	1.26	30.6	1.57	34.4	1.85	38.2	2.15	42.8	2.47	45.5	2.70	49.3	3.06
	80	25.2	1.33	30.6	1.69	34.4	1.99	38.2	2.31	42.8	2.66	45.5	2.91	49.3	3.29
	85	25.2	1.51	30.6	1.94	34.4	2.28	38.2	2.66	42.8	3.07	45.5	3.36	49.3	3.82
	90	25.2	1.62	30.6	2.07	34.4	2.45	38.2	2.86	42.8	3.30	45.5	3.61	49.3	4.11
	95	25.2	1.73	30.6	2.22	34.4	2.62	38.2	3.06	42.8	3.54	45.5	3.88	49.3	4.41
	100	25.2	1.84	30.6	2.37	34.4	2.80	38.2	3.28	42.8	3.79	45.5	4.16	49.3	4.74
	105	25.2	1.99	30.6	2.57	34.4	3.03	38.2	3.55	42.8	4.11	45.5	4.50	48.6	4.99
110	25.2	2.02	30.6	2.60	34.4	3.06	38.2	3.58	42.8	4.14	45.5	4.53	48.6	5.02	
115	25.2	2.04	30.6	2.63	34.4	3.09	38.2	3.62	42.8	4.17	45.5	4.57	48.6	5.07	

Capacity rated using ISO 5151—Test Rating Standard for Non-Ducted Heat Pumps.
 Cooling mode stable operation is ensured when the outdoor ambient dry-bulb temperature is between 23°F and 115°F.
 Rapid cooling operation is stable at indoor temperatures up to 80°F DB.
 Power Input (PI) in kW and includes compressor(s) and outdoor fan motor(s).
 Rated with an equivalent piping length of 24.6 ft. and no change in elevation between the indoor and outdoor unit.
 MBh = Net Capacity
 R410A, 60 Hz

Due to differences in test method and procedures, capacity data values provided in these tables may differ from certified performance information published by AHRI or other standardized testing agencies. AHRI testing protocol sets the volume of air flowing over the coil at 444 CFM/ton and limits the number of indoor units connected to the system being tested. LG conducts capacity tests using airflow rates and limits the number of indoor units per system as stated in Table 4 (a and b) on pages 17–18, Table 5 on page 19, and Table 14 on page 56.



Table 13c: ARUN047GS2 Heat Pump—Nominal Cooling Capacity

Combination Ratio (%)	Outdoor Air Temp (°F) DB	Indoor Air Temperature (°F) WB													
		57		61		64		67		70		73		76	
		MBh	PI	MBh	PI	MBh	PI	MBh	PI	MBh	PI	MBh	PI	MBh	PI
70	23	22.1	0.81	26.8	1.02	30.1	1.17	33.5	1.35	37.5	1.53	39.8	1.63	43.2	1.83
	25	22.1	0.84	26.8	1.04	30.1	1.20	33.5	1.37	37.5	1.55	39.8	1.65	43.2	1.86
	30	22.1	0.87	26.8	1.07	30.1	1.22	33.5	1.40	37.5	1.58	39.8	1.68	43.2	1.88
	35	22.1	0.89	26.8	1.09	30.1	1.25	33.5	1.42	37.5	1.60	39.8	1.70	43.2	1.91
	40	22.1	0.94	26.8	1.14	30.1	1.30	33.5	1.48	37.5	1.65	39.8	1.76	43.2	1.96
	45	22.1	0.97	26.8	1.17	30.1	1.32	33.5	1.50	37.5	1.68	39.8	1.78	43.2	1.98
	50	22.1	0.99	26.8	1.19	30.1	1.35	33.5	1.52	37.5	1.70	39.8	1.82	43.2	2.00
	55	22.1	1.00	26.8	1.21	30.1	1.38	33.5	1.55	37.5	1.74	39.8	1.86	43.2	2.05
	60	22.1	1.04	26.8	1.26	30.1	1.43	33.5	1.62	37.5	1.81	39.8	1.94	43.2	2.14
	65	22.1	1.06	26.8	1.28	30.1	1.46	33.5	1.65	37.5	1.84	39.8	1.98	43.2	2.18
	70	22.1	1.08	26.8	1.31	30.1	1.50	33.5	1.69	37.5	1.89	39.8	2.03	43.2	2.29
	75	22.1	1.10	26.8	1.34	30.1	1.55	33.5	1.79	37.5	2.05	39.8	2.23	43.2	2.52
	80	22.1	1.14	26.8	1.43	30.1	1.67	33.5	1.93	37.5	2.21	39.8	2.40	43.2	2.71
	85	22.1	1.30	26.8	1.64	30.1	1.92	33.5	2.22	37.5	2.54	39.8	2.77	43.2	3.13
	90	22.1	1.39	26.8	1.75	30.1	2.05	33.5	2.37	37.5	2.73	39.8	2.97	43.2	3.36
95	22.1	1.48	26.8	1.87	30.1	2.19	33.5	2.54	37.5	2.92	39.8	3.19	43.2	3.61	
100	22.1	1.57	26.8	1.99	30.1	2.34	33.5	2.72	37.5	3.13	39.8	3.42	43.2	3.87	
105	22.1	1.70	26.8	2.14	30.1	2.52	33.5	2.93	37.5	3.38	39.8	3.69	43.2	4.17	
110	22.1	1.73	26.8	2.16	30.1	2.54	33.5	2.95	37.5	3.41	39.8	3.71	43.2	4.20	
115	22.1	1.74	26.8	2.18	30.1	2.57	33.5	2.98	37.5	3.44	39.8	3.75	43.2	4.23	
60	23	18.9	0.68	22.9	0.85	25.8	0.97	28.7	1.12	32.1	1.26	34.1	1.35	37.0	1.51
	25	18.9	0.70	22.9	0.87	25.8	1.00	28.7	1.14	32.1	1.29	34.1	1.37	37.0	1.53
	30	18.9	0.73	22.9	0.89	25.8	1.02	28.7	1.16	32.1	1.31	34.1	1.39	37.0	1.55
	35	18.9	0.77	22.9	0.93	25.8	1.06	28.7	1.20	32.1	1.35	34.1	1.43	37.0	1.60
	40	18.9	0.79	22.9	0.95	25.8	1.08	28.7	1.22	32.1	1.37	34.1	1.45	37.0	1.62
	45	18.9	0.79	22.9	0.95	25.8	1.08	28.7	1.22	32.1	1.37	34.1	1.45	37.0	1.62
	50	18.9	0.80	22.9	0.97	25.8	1.10	28.7	1.24	32.1	1.39	34.1	1.48	37.0	1.63
	55	18.9	0.82	22.9	0.99	25.8	1.12	28.7	1.27	32.1	1.41	34.1	1.51	37.0	1.67
	60	18.9	0.85	22.9	1.03	25.8	1.17	28.7	1.32	32.1	1.47	34.1	1.58	37.0	1.74
	65	18.9	0.86	22.9	1.05	25.8	1.19	28.7	1.35	32.1	1.50	34.1	1.61	37.0	1.78
	70	18.9	0.88	22.9	1.07	25.8	1.22	28.7	1.37	32.1	1.54	34.1	1.65	37.0	1.87
	75	18.9	0.90	22.9	1.09	25.8	1.27	28.7	1.46	32.1	1.67	34.1	1.82	37.0	2.05
	80	18.9	0.93	22.9	1.16	25.8	1.36	28.7	1.57	32.1	1.80	34.1	1.96	37.0	2.21
	85	18.9	1.13	22.9	1.43	25.8	1.67	28.7	1.93	32.1	2.22	34.1	2.42	37.0	2.74
	90	18.9	1.13	22.9	1.43	25.8	1.67	28.7	1.93	32.1	2.22	34.1	2.42	37.0	2.74
95	18.9	1.20	22.9	1.52	25.8	1.79	28.7	2.07	32.1	2.38	34.1	2.60	37.0	2.94	
100	18.9	1.28	22.9	1.62	25.8	1.91	28.7	2.22	32.1	2.55	34.1	2.78	37.0	3.16	
105	18.9	1.39	22.9	1.74	25.8	2.05	28.7	2.38	32.1	2.76	34.1	3.01	37.0	3.40	
110	18.9	1.41	22.9	1.76	25.8	2.07	28.7	2.40	32.1	2.78	34.1	3.03	37.0	3.42	
115	18.9	1.42	22.9	1.78	25.8	2.09	28.7	2.43	32.1	2.80	34.1	3.05	37.0	3.45	
50	23	15.8	0.53	19.1	0.66	21.5	0.76	23.9	0.88	26.8	0.99	28.4	1.06	30.8	1.19
	25	15.8	0.55	19.1	0.68	21.5	0.78	23.9	0.89	26.8	1.01	28.4	1.07	30.8	1.21
	30	15.8	0.56	19.1	0.69	21.5	0.79	23.9	0.91	26.8	1.02	28.4	1.09	30.8	1.22
	35	15.8	0.58	19.1	0.71	21.5	0.81	23.9	0.93	26.8	1.04	28.4	1.11	30.8	1.24
	40	15.8	0.61	19.1	0.74	21.5	0.84	23.9	0.96	26.8	1.07	28.4	1.14	30.8	1.27
	45	15.8	0.63	19.1	0.76	21.5	0.86	23.9	0.98	26.8	1.09	28.4	1.16	30.8	1.29
	50	15.8	0.64	19.1	0.77	21.5	0.88	23.9	0.99	26.8	1.11	28.4	1.18	30.8	1.30
	55	15.8	0.65	19.1	0.79	21.5	0.89	23.9	1.01	26.8	1.13	28.4	1.21	30.8	1.33
	60	15.8	0.68	19.1	0.82	21.5	0.93	23.9	1.05	26.8	1.18	28.4	1.26	30.8	1.39
	65	15.8	0.69	19.1	0.83	21.5	0.95	23.9	1.07	26.8	1.20	28.4	1.29	30.8	1.42
	70	15.8	0.70	19.1	0.85	21.5	0.97	23.9	1.10	26.8	1.23	28.4	1.32	30.8	1.49
	75	15.8	0.72	19.1	0.87	21.5	1.01	23.9	1.17	26.8	1.33	28.4	1.45	30.8	1.64
	80	15.8	0.74	19.1	0.93	21.5	1.08	23.9	1.25	26.8	1.43	28.4	1.56	30.8	1.76
	85	15.8	0.90	19.1	1.14	21.5	1.33	23.9	1.54	26.8	1.77	28.4	1.93	30.8	2.18
	90	15.8	0.90	19.1	1.14	21.5	1.33	23.9	1.54	26.8	1.77	28.4	1.93	30.8	2.18
95	15.8	0.96	19.1	1.21	21.5	1.42	23.9	1.65	26.8	1.90	28.4	2.07	30.8	2.35	
100	15.8	1.02	19.1	1.29	21.5	1.52	23.9	1.77	26.8	2.03	28.4	2.22	30.8	2.52	
105	15.8	1.11	19.1	1.39	21.5	1.64	23.9	1.90	26.8	2.20	28.4	2.40	30.8	2.71	
110	15.8	1.12	19.1	1.40	21.5	1.65	23.9	1.92	26.8	2.21	28.4	2.41	30.8	2.73	
115	15.8	1.13	19.1	1.42	21.5	1.67	23.9	1.94	26.8	2.23	28.4	2.23	30.8	2.75	

Capacity rated using ISO 5151—Test Rating Standard for Non-Ducted Heat Pumps.
 Cooling mode stable operation is ensured when the outdoor ambient dry-bulb temperature is between 23°F and 115°F.
 Rapid cooling operation is stable at indoor temperatures up to 80°F DB.
 Power Input (PI) in kW and includes compressor(s) and outdoor fan motor(s).
 Rated with an equivalent piping length of 24.6 ft. and no change in elevation between the indoor and outdoor unit.
 MBh = Net Capacity
 R410A, 60 Hz

Due to differences in test method and procedures, capacity data values provided in these tables may differ from certified performance information published by AHRI or other standardized testing agencies. AHRI testing protocol sets the volume of air flowing over the coil at 444 CFM/ton and limits the number of indoor units connected to the system being tested. LG conducts capacity tests using airflow rates and limits the number of indoor units per system as stated in Table 4 (a and b) on pages 17–18, Table 5 on page 19, and Table 14 on page 56.

MULTI VTM
MINI
HEAT PUMP CONDENSING UNIT ENGINEERING MANUAL

PERFORMANCE DATA



Cooling Capacity—4.4 Ton

Table 14a: ARUN053GS2 Heat Pump—Nominal Cooling Capacity

Combination Ratio (%)	Outdoor Air Temp (°F) DB	Indoor Air Temperature (°F) WB													
		57		61		64		67		70		73		76	
		MBh	PI	MBh	PI	MBh	PI	MBh	PI	MBh	PI	MBh	PI	MBh	PI
130	23	45.3	2.17	54.6	2.77	62.2	3.26	69.2	3.74	71.5	3.62	72.1	3.53	73.8	3.44
	25	45.3	2.20	54.6	2.80	62.2	3.29	69.2	3.77	71.5	3.65	72.1	3.56	73.8	3.47
	30	45.3	2.23	54.6	2.83	62.2	3.32	69.2	3.80	71.5	3.68	72.1	3.59	73.8	3.50
	35	45.3	2.26	54.6	2.86	62.2	3.35	69.2	3.83	71.5	3.71	72.1	3.62	73.8	3.53
	40	45.3	2.32	54.6	2.93	62.2	3.41	69.2	3.89	71.5	3.77	72.1	3.71	73.8	3.59
	45	45.3	2.35	54.6	2.96	62.2	3.44	69.2	3.92	71.5	3.80	72.1	3.74	73.8	3.62
	50	45.3	2.43	54.6	3.04	62.2	3.51	69.2	3.97	71.5	3.88	72.1	3.78	73.8	3.69
	55	45.3	2.48	54.6	3.10	62.2	3.58	69.2	3.99	70.3	3.89	71.5	3.79	72.7	3.72
	60	45.3	2.58	54.6	3.23	62.2	3.74	66.9	4.11	68.6	4.14	69.2	4.16	70.9	4.19
	65	45.3	2.64	54.6	3.34	62.2	4.02	65.7	4.34	67.4	4.37	68.0	4.40	69.8	4.43
	70	45.3	2.73	54.6	3.61	62.2	4.35	65.1	4.57	66.3	4.61	67.4	4.63	68.6	4.66
	75	45.3	2.99	54.6	3.97	62.2	4.80	63.9	4.86	65.1	4.90	66.3	4.93	67.4	4.96
	80	45.3	3.22	54.6	4.28	61.0	5.05	62.8	5.09	63.9	5.14	65.1	5.16	66.3	5.20
	85	45.3	3.72	54.6	4.96	59.3	5.51	60.5	5.56	62.2	5.61	62.8	5.64	64.5	5.69
	90	45.3	3.99	54.6	5.33	58.1	5.75	59.9	5.80	61.0	5.85	62.2	5.88	63.4	5.93
	95	45.3	4.28	54.6	5.73	57.6	5.98	58.1	6.03	59.9	6.09	61.0	6.13	62.8	6.18
	100	45.3	4.59	54.6	6.15	56.4	6.22	57.6	6.27	59.3	6.33	59.9	6.36	61.6	6.42
	105	44.2	5.01	51.7	6.51	52.9	6.75	54.6	7.24	55.8	7.54	57.6	7.66	58.7	7.78
110	40.7	5.13	48.3	6.63	49.4	7.00	51.2	7.78	52.3	8.02	55.8	8.32	57.0	8.50	
115	40.3	5.17	47.8	6.70	48.9	7.06	50.6	7.85	51.8	8.10	55.2	8.40	56.4	8.58	
120	23	41.7	1.98	50.8	2.52	57.7	2.94	63.9	3.42	70.2	3.72	70.8	3.69	72.5	3.54
	25	41.7	2.01	50.8	2.55	57.7	2.97	63.9	3.45	70.2	3.75	70.8	3.72	72.5	3.57
	30	41.7	2.04	50.8	2.58	57.7	3.00	63.9	3.48	70.2	3.78	70.8	3.75	72.5	3.60
	35	41.7	2.07	50.8	2.61	57.7	3.03	63.9	3.51	70.2	3.81	70.8	3.78	72.5	3.63
	40	41.7	2.13	50.8	2.67	57.7	3.09	63.9	3.57	70.2	3.87	70.8	3.84	72.5	3.69
	45	41.7	2.16	50.8	2.70	57.7	3.12	63.9	3.60	70.2	3.90	70.8	3.87	72.5	3.72
	50	41.7	2.22	50.8	2.77	57.7	3.20	63.9	3.64	70.2	3.95	70.8	3.88	72.5	3.78
	55	41.7	2.26	50.8	2.83	57.7	3.27	63.9	3.72	69.1	3.97	70.2	3.89	71.4	3.79
	60	41.7	2.36	50.8	2.95	57.7	3.41	63.9	3.88	67.4	4.12	67.9	4.14	69.1	4.16
	65	41.7	2.41	50.8	3.01	57.7	3.57	63.9	4.21	66.2	4.35	67.4	4.37	68.5	4.40
	70	41.3	2.56	50.3	3.34	57.1	4.01	63.3	4.72	64.4	4.76	65.6	4.78	66.7	4.81
	75	41.7	2.68	50.8	3.53	57.7	4.25	62.8	4.83	63.9	4.87	65.1	4.89	66.2	4.93
	80	41.7	2.89	50.8	3.81	57.7	4.58	61.7	5.06	62.8	5.10	63.9	5.13	65.1	5.17
	85	41.7	3.32	50.8	4.40	57.7	5.31	59.4	5.53	61.1	5.57	61.7	5.60	63.4	5.64
	90	41.7	3.57	50.8	4.73	57.1	5.71	58.8	5.76	59.9	5.81	61.1	5.84	62.2	5.88
	95	41.7	3.82	50.8	5.08	56.5	5.94	57.1	5.99	58.8	6.04	59.9	6.08	61.1	6.13
	100	41.7	4.09	50.8	5.45	55.4	6.18	56.5	6.23	58.2	6.29	58.8	6.32	59.9	6.36
	105	40.0	4.49	47.4	5.99	50.8	6.53	53.7	7.19	54.8	7.49	56.5	7.61	57.7	7.73
110	38.8	4.91	45.1	6.41	46.8	6.95	50.2	7.73	51.4	7.97	54.8	8.27	55.9	8.45	
115	38.4	4.96	44.6	6.47	46.3	7.01	49.7	7.80	50.8	8.04	54.3	8.35	55.4	8.53	
110	23	38.1	1.79	46.5	2.26	52.7	2.68	58.8	3.04	65.0	3.45	68.9	3.75	71.2	3.63
	25	38.1	1.82	46.5	2.29	52.7	2.71	58.8	3.07	65.0	3.48	68.9	3.78	71.2	3.66
	30	38.1	1.85	46.5	2.32	52.7	2.74	58.8	3.10	65.0	3.51	68.9	3.81	71.2	3.69
	35	38.1	1.88	46.5	2.35	52.7	2.77	58.8	3.13	65.0	3.54	68.9	3.84	71.2	3.72
	40	38.1	1.94	46.5	2.41	52.7	2.83	58.8	3.19	65.0	3.60	68.9	3.90	71.2	3.78
	45	38.1	1.97	46.5	2.44	52.7	2.86	58.8	3.22	65.0	3.63	68.9	3.93	71.2	3.81
	50	38.1	2.01	46.5	2.51	52.7	2.89	58.8	3.29	65.0	3.69	68.9	3.97	71.2	3.88
	55	38.1	2.06	46.5	2.56	52.7	2.96	58.8	3.36	65.0	3.78	68.9	3.98	70.1	3.89
	60	38.1	2.14	46.5	2.67	52.7	3.08	58.8	3.51	65.0	3.97	66.7	4.11	67.8	4.14
	65	38.1	2.19	46.5	2.73	52.7	3.15	58.8	3.70	65.0	4.30	65.6	4.34	67.2	4.37
	70	38.1	2.24	46.5	2.84	52.7	3.39	58.8	4.00	63.9	4.55	65.0	4.57	66.1	4.60
	75	38.1	2.38	46.5	3.12	52.7	3.74	58.8	4.41	62.8	4.84	63.3	4.86	65.0	4.89
	80	38.1	2.56	46.5	3.36	52.7	4.02	58.8	4.75	61.6	5.07	62.8	5.09	63.9	5.13
	85	38.1	2.95	46.5	3.88	52.7	4.66	58.8	5.49	60.0	5.54	60.5	5.56	61.6	5.60
	90	38.1	3.16	46.5	4.16	52.7	5.01	57.7	5.72	58.8	5.76	59.4	5.80	61.1	5.83
	95	38.1	3.39	46.5	4.47	52.7	5.38	56.0	5.95	57.7	6.00	58.8	6.03	60.0	6.08
	100	38.1	3.62	46.5	4.79	52.7	5.77	55.5	6.19	56.6	6.23	57.7	6.27	58.8	6.32
	105	35.9	3.99	41.5	5.36	48.8	6.31	52.7	7.15	53.8	7.44	55.5	7.56	56.6	7.68
110	34.7	4.41	39.2	5.78	44.8	7.32	49.3	7.68	50.4	7.92	53.8	8.22	54.9	8.40	
115	34.4	4.45	38.8	5.83	44.3	7.39	48.8	7.75	49.9	7.99	53.2	8.29	54.3	8.47	

Capacity rated using ISO 5151—Test Rating Standard for Non-Ducted Heat Pumps.
 Cooling mode stable operation is ensured when the outdoor ambient dry-bulb temperature is between 23°F and 115°F.
 Rapid cooling operation is stable at indoor temperatures up to 80°F DB.
 Power Input (PI) in kW and includes compressor(s) and outdoor fan motor(s).
 Rated with an equivalent piping length of 24.6 ft. and no change in elevation between the indoor and outdoor unit.
 MBh = Net Capacity
 R410A, 60 Hz

Due to differences in test method and procedures, capacity data values provided in these tables may differ from certified performance information published by AHRI or other standardized testing agencies. AHRI testing protocol sets the volume of air flowing over the coil at 444 CFM/ton and limits the number of indoor units connected to the system being tested. LG conducts capacity tests using airflow rates and limits the number of indoor units per system as stated in Table 4 (a and b) on pages 17–18, Table 5 on page 19, and Table 14 on page 56.



Table 14b: ARUN053GS2 Heat Pump—Nominal Cooling Capacity

Combination Ratio (%)	Outdoor Air Temp (°F) DB	Indoor Air Temperature (°F) WB													
		57		61		64		67		70		73		76	
		MBh	PI	MBh	PI	MBh	PI	MBh	PI	MBh	PI	MBh	PI	MBh	PI
100	23	34.9	1.38	42.3	1.82	47.6	2.09	52.9	2.20	59.2	2.87	63.0	3.09	68.2	3.53
	25	34.9	1.43	42.3	1.87	47.6	2.15	52.9	2.31	59.2	2.92	63.0	3.14	68.2	3.58
	30	34.9	1.49	42.3	1.93	47.6	2.20	52.9	2.42	59.2	2.98	63.0	3.20	68.2	3.64
	35	34.9	1.54	42.3	1.98	47.6	2.26	52.9	2.53	59.2	3.03	63.0	3.25	68.2	3.69
	40	34.9	1.65	42.3	2.09	47.6	2.37	52.9	2.76	59.2	3.14	63.0	3.36	68.2	3.80
	45	34.9	1.71	42.3	2.15	47.6	2.48	52.9	2.87	59.2	3.20	63.0	3.42	68.2	3.86
	50	34.9	1.82	42.3	2.25	47.6	2.59	52.9	2.95	59.2	3.31	63.0	3.55	68.2	3.93
	55	34.9	1.86	42.3	2.30	47.6	2.65	52.9	3.01	59.2	3.38	63.0	3.63	68.2	4.00
	60	34.9	1.93	42.3	2.40	47.6	2.76	52.9	3.14	59.2	3.53	63.0	3.79	66.7	4.11
	65	34.9	1.97	42.3	2.45	47.6	2.82	52.9	3.21	59.2	3.72	63.0	4.09	65.6	4.33
	70	34.9	2.01	42.3	2.50	47.6	2.96	52.9	3.48	59.2	4.03	63.0	4.42	64.5	4.56
	75	34.9	2.11	42.3	2.73	47.6	3.25	52.9	3.83	59.2	4.44	62.4	4.82	63.5	4.86
	80	34.9	2.26	42.3	2.94	47.6	3.50	52.9	4.12	59.2	4.79	61.4	5.05	62.4	5.08
	85	34.9	2.60	42.3	3.39	47.6	4.05	52.9	4.77	58.7	5.49	59.2	5.52	60.3	5.55
	90	34.9	2.78	42.3	3.64	47.6	4.35	52.9	5.13	57.7	5.73	58.2	5.75	59.2	5.79
95	34.9	2.97	42.3	3.90	47.6	4.66	52.9	5.51	56.6	5.95	57.7	5.99	58.7	6.02	
100	34.9	3.18	42.3	4.17	47.6	5.01	52.9	5.92	55.5	6.19	56.6	6.22	57.7	6.27	
105	34.9	3.58	40.2	4.85	45.5	5.73	50.8	6.61	51.8	6.78	54.5	6.89	55.5	7.11	
110	33.9	3.97	38.1	5.23	42.3	6.67	47.6	7.11	48.7	7.22	51.8	7.49	54.0	7.66	
115	33.5	4.00	37.7	5.28	41.9	6.73	47.1	7.17	48.2	7.28	51.3	7.56	53.4	7.73	
90	23	31.4	1.32	38.1	1.65	42.8	1.98	47.6	2.26	53.3	2.59	56.7	2.83	61.4	3.16
	25	31.4	1.37	38.1	1.70	42.8	2.02	47.6	2.31	53.3	2.64	56.7	2.87	61.4	3.20
	30	31.4	1.41	38.1	1.74	42.8	2.07	47.6	2.35	53.3	2.68	56.7	2.92	61.4	3.25
	35	31.4	1.46	38.1	1.79	42.8	2.12	47.6	2.40	53.3	2.73	56.7	2.97	61.4	3.30
	40	31.4	1.55	38.1	1.88	42.8	2.21	47.6	2.50	53.3	2.83	56.7	3.06	61.4	3.39
	45	31.4	1.60	38.1	1.93	42.8	2.26	47.6	2.54	53.3	2.87	56.7	3.11	61.4	3.44
	50	31.4	1.63	38.1	2.01	42.8	2.30	47.6	2.61	53.3	2.93	56.7	3.15	61.4	3.48
	55	31.4	1.67	38.1	2.05	42.8	2.35	47.6	2.66	53.3	2.99	56.7	3.21	61.4	3.55
	60	31.4	1.73	38.1	2.13	42.8	2.45	47.6	2.78	53.3	3.12	56.7	3.35	61.4	3.71
	65	31.4	1.76	38.1	2.17	42.8	2.50	47.6	2.84	53.3	3.19	56.7	3.49	61.4	3.97
	70	31.4	1.80	38.1	2.22	42.8	2.56	47.6	2.99	53.3	3.45	56.7	3.78	61.4	4.30
	75	31.4	1.85	38.1	2.37	42.8	2.81	47.6	3.28	53.3	3.79	56.7	4.16	61.4	4.73
	80	31.4	1.98	38.1	2.55	42.8	3.02	47.6	3.53	53.3	4.09	56.7	4.48	60.9	5.05
	85	31.4	2.27	38.1	2.93	42.8	3.48	47.6	4.09	53.3	4.73	56.7	5.20	59.0	5.51
	90	31.4	2.43	38.1	3.14	42.8	3.74	47.6	4.39	53.3	5.09	56.7	5.59	58.1	5.75
95	31.4	2.59	38.1	3.36	42.8	4.00	47.6	4.71	53.3	5.47	56.2	5.94	57.1	5.97	
100	31.4	2.77	38.1	3.60	42.8	4.29	47.6	5.05	53.3	5.77	55.2	6.17	56.2	6.21	
105	31.4	3.01	38.1	3.91	42.4	4.66	47.1	5.46	52.4	6.30	53.3	6.42	54.3	6.42	
110	31.4	3.06	38.1	3.96	41.9	4.71	46.7	5.51	50.0	6.36	52.4	6.45	53.3	6.45	
115	31.4	3.08	38.1	3.99	41.9	4.75	46.7	5.56	50.0	6.41	52.4	6.51	53.3	6.51	
80	23	27.9	1.15	33.9	1.47	38.1	1.75	42.3	2.03	47.4	2.26	50.4	2.46	54.6	2.74
	25	27.9	1.19	33.9	1.51	38.1	1.79	42.3	2.07	47.4	2.30	50.4	2.50	54.6	2.78
	30	27.9	1.23	33.9	1.55	38.1	1.83	42.3	2.11	47.4	2.34	50.4	2.54	54.6	2.82
	35	27.9	1.27	33.9	1.59	38.1	1.87	42.3	2.14	47.4	2.38	50.4	2.58	54.6	2.86
	40	27.9	1.35	33.9	1.67	38.1	1.95	42.3	2.22	47.4	2.46	50.4	2.66	54.6	2.94
	45	27.9	1.39	33.9	1.71	38.1	1.99	42.3	2.26	47.4	2.50	50.4	2.70	54.6	2.98
	50	27.9	1.45	33.9	1.77	38.1	2.02	42.3	2.29	47.4	2.56	50.4	2.75	54.6	3.03
	55	27.9	1.47	33.9	1.80	38.1	2.07	42.3	2.33	47.4	2.61	50.4	2.80	54.6	3.10
	60	27.9	1.53	33.9	1.87	38.1	2.15	42.3	2.43	47.4	2.73	50.4	2.92	54.6	3.23
	65	27.9	1.56	33.9	1.91	38.1	2.19	42.3	2.48	47.4	2.78	50.4	2.99	54.6	3.33
	70	27.9	1.60	33.9	1.95	38.1	2.24	42.3	2.54	47.4	2.91	50.4	3.18	54.6	3.60
	75	27.9	1.63	33.9	2.03	38.1	2.40	42.3	2.78	47.4	3.20	50.4	3.50	54.6	3.97
	80	27.9	1.72	33.9	2.19	38.1	2.57	42.3	2.99	47.4	3.44	50.4	3.77	54.6	4.27
	85	27.9	1.96	33.9	2.51	38.1	2.96	42.3	3.45	47.4	3.98	50.4	4.36	54.6	4.95
	90	27.9	2.10	33.9	2.68	38.1	3.17	42.3	3.71	47.4	4.28	50.4	4.68	54.6	5.33
95	27.9	2.24	33.9	2.87	38.1	3.40	42.3	3.97	47.4	4.59	50.4	5.03	54.6	5.72	
100	27.9	2.39	33.9	3.07	38.1	3.64	42.3	4.25	47.4	4.92	50.4	5.39	54.6	6.14	
105	27.9	2.58	33.9	3.34	38.1	3.93	42.3	4.61	47.4	5.32	50.4	5.84	53.7	6.47	
110	27.9	2.62	33.9	3.38	38.1	3.97	42.3	4.65	47.4	5.36	50.4	5.88	53.7	6.51	
115	27.9	2.64	33.9	3.41	38.1	4.01	42.3	4.69	47.4	5.41	50.4	5.93	53.7	6.57	

Capacity rated using ISO 5151—Test Rating Standard for Non-Ducted Heat Pumps.
 Cooling mode stable operation is ensured when the outdoor ambient dry-bulb temperature is between 23°F and 115°F.
 Rapid cooling operation is stable at indoor temperatures up to 80°F DB.
 Power Input (PI) in kW and includes compressor(s) and outdoor fan motor(s).
 Rated with an equivalent piping length of 24.6 ft. and no change in elevation between the indoor and outdoor unit.
 MBh = Net Capacity
 R410A, 60 Hz

Due to differences in test method and procedures, capacity data values provided in these tables may differ from certified performance information published by AHRI or other standardized testing agencies. AHRI testing protocol sets the volume of air flowing over the coil at 444 CFM/ton and limits the number of indoor units connected to the system being tested. LG conducts capacity tests using airflow rates and limits the number of indoor units per system as stated in Table 4 (a and b) on pages 17–18, Table 5 on page 19, and Table 14 on page 56.

MULTI V
MINI
HEAT PUMP CONDENSING UNIT ENGINEERING MANUAL

PERFORMANCE DATA



Cooling Capacity—4.4 Ton

Table 14c: ARUN053GS2 Heat Pump—Nominal Cooling Capacity

Combination Ratio (%)	Outdoor Air Temp (°F) DB	Indoor Air Temperature (°F) WB													
		57		61		64		67		70		73		76	
		MBh	PI	MBh	PI	MBh	PI	MBh	PI	MBh	PI	MBh	PI	MBh	PI
70	23	24.4	1.06	29.6	1.32	33.3	1.52	37.0	1.75	41.5	1.98	44.1	2.11	47.8	2.37
	25	24.4	1.09	29.6	1.35	33.3	1.55	37.0	1.78	41.5	2.01	44.1	2.14	47.8	2.41
	30	24.4	1.12	29.6	1.39	33.3	1.58	37.0	1.81	41.5	2.04	44.1	2.18	47.8	2.44
	35	24.4	1.15	29.6	1.42	33.3	1.62	37.0	1.85	41.5	2.08	44.1	2.21	47.8	2.47
	40	24.4	1.22	29.6	1.48	33.3	1.68	37.0	1.91	41.5	2.14	44.1	2.28	47.8	2.54
	45	24.4	1.25	29.6	1.52	33.3	1.72	37.0	1.95	41.5	2.18	44.1	2.31	47.8	2.57
	50	24.4	1.28	29.6	1.54	33.3	1.75	37.0	1.98	41.5	2.21	44.1	2.36	47.8	2.60
	55	24.4	1.30	29.6	1.57	33.3	1.79	37.0	2.01	41.5	2.25	44.1	2.41	47.8	2.66
	60	24.4	1.35	29.6	1.63	33.3	1.86	37.0	2.10	41.5	2.35	44.1	2.51	47.8	2.77
	65	24.4	1.37	29.6	1.67	33.3	1.89	37.0	2.14	41.5	2.39	44.1	2.57	47.8	2.83
	70	24.4	1.40	29.6	1.70	33.3	1.94	37.0	2.19	41.5	2.45	44.1	2.63	47.8	2.97
	75	24.4	1.43	29.6	1.74	33.3	2.01	37.0	2.33	41.5	2.66	44.1	2.89	47.8	3.27
	80	24.4	1.48	29.6	1.85	33.3	2.16	37.0	2.50	41.5	2.86	44.1	3.11	47.8	3.51
	85	24.4	1.68	29.6	2.12	33.3	2.48	37.0	2.87	41.5	3.29	44.1	3.59	47.8	4.06
	90	24.4	1.80	29.6	2.27	33.3	2.66	37.0	3.08	41.5	3.53	44.1	3.85	47.8	4.36
95	24.4	1.91	29.6	2.42	33.3	2.84	37.0	3.30	41.5	3.79	44.1	4.13	47.8	4.68	
100	24.4	2.04	29.6	2.58	33.3	3.04	37.0	3.53	41.5	4.05	44.1	4.43	47.8	5.02	
105	24.4	2.21	29.6	2.77	33.3	3.27	37.0	3.79	41.5	4.39	44.1	4.78	47.8	5.41	
110	24.4	2.24	29.6	2.80	33.3	3.30	37.0	3.83	41.5	4.42	44.1	4.82	47.8	5.44	
115	24.4	2.26	29.6	2.82	33.3	3.33	37.0	3.86	41.5	4.46	44.1	4.86	47.8	5.49	
60	23	20.9	0.89	25.4	1.10	28.6	1.26	31.7	1.45	35.5	1.64	37.8	1.75	40.9	1.96
	25	20.9	0.91	25.4	1.13	28.6	1.29	31.7	1.48	35.5	1.67	37.8	1.77	40.9	1.99
	30	20.9	0.94	25.4	1.16	28.6	1.32	31.7	1.51	35.5	1.69	37.8	1.80	40.9	2.02
	35	20.9	0.99	25.4	1.21	28.6	1.37	31.7	1.56	35.5	1.75	37.8	1.85	40.9	2.07
	40	20.9	1.02	25.4	1.24	28.6	1.40	31.7	1.59	35.5	1.77	37.8	1.88	40.9	2.10
	45	20.9	1.02	25.4	1.24	28.6	1.40	31.7	1.59	35.5	1.77	37.8	1.88	40.9	2.10
	50	20.9	1.04	25.4	1.26	28.6	1.43	31.7	1.61	35.5	1.80	37.8	1.92	40.9	2.12
	55	20.9	1.06	25.4	1.28	28.6	1.46	31.7	1.64	35.5	1.83	37.8	1.96	40.9	2.16
	60	20.9	1.10	25.4	1.33	28.6	1.51	31.7	1.71	35.5	1.91	37.8	2.05	40.9	2.26
	65	20.9	1.12	25.4	1.36	28.6	1.54	31.7	1.75	35.5	1.95	37.8	2.09	40.9	2.30
	70	20.9	1.14	25.4	1.38	28.6	1.58	31.7	1.78	35.5	1.99	37.8	2.14	40.9	2.42
	75	20.9	1.17	25.4	1.42	28.6	1.64	31.7	1.90	35.5	2.16	37.8	2.36	40.9	2.66
	80	20.9	1.21	25.4	1.51	28.6	1.76	31.7	2.04	35.5	2.33	37.8	2.54	40.9	2.86
	85	20.9	1.47	25.4	1.85	28.6	2.16	31.7	2.51	35.5	2.88	37.8	3.14	40.9	3.55
	90	20.9	1.47	25.4	1.85	28.6	2.16	31.7	2.51	35.5	2.88	37.8	3.14	40.9	3.55
95	20.9	1.56	25.4	1.97	28.6	2.31	31.7	2.69	35.5	3.09	37.8	3.37	40.9	3.82	
100	20.9	1.66	25.4	2.10	28.6	2.48	31.7	2.87	35.5	3.30	37.8	3.61	40.9	4.09	
105	20.9	1.80	25.4	2.26	28.6	2.66	31.7	3.09	35.5	3.57	37.8	3.90	40.9	4.41	
110	20.9	1.83	25.4	2.28	28.6	2.69	31.7	3.12	35.5	3.60	37.8	3.92	40.9	4.43	
115	20.9	1.85	25.4	2.30	28.6	2.71	31.7	3.15	35.5	3.63	37.8	3.93	40.9	4.47	
50	23	17.5	0.69	21.2	0.86	23.8	0.99	26.5	1.14	29.6	1.29	31.5	1.37	34.1	1.54
	25	17.5	0.71	21.2	0.88	23.8	1.01	26.5	1.16	29.6	1.31	31.5	1.39	34.1	1.56
	30	17.5	0.73	21.2	0.90	23.8	1.03	26.5	1.18	29.6	1.33	31.5	1.41	34.1	1.59
	35	17.5	0.75	21.2	0.92	23.8	1.05	26.5	1.20	29.6	1.35	31.5	1.44	34.1	1.61
	40	17.5	0.79	21.2	0.96	23.8	1.09	26.5	1.24	29.6	1.39	31.5	1.48	34.1	1.65
	45	17.5	0.81	21.2	0.99	23.8	1.11	26.5	1.26	29.6	1.41	31.5	1.50	34.1	1.67
	50	17.5	0.83	21.2	1.00	23.8	1.14	26.5	1.28	29.6	1.43	31.5	1.53	34.1	1.69
	55	17.5	0.85	21.2	1.02	23.8	1.16	26.5	1.31	29.6	1.46	31.5	1.56	34.1	1.73
	60	17.5	0.88	21.2	1.06	23.8	1.21	26.5	1.36	29.6	1.52	31.5	1.63	34.1	1.80
	65	17.5	0.89	21.2	1.08	23.8	1.23	26.5	1.39	29.6	1.55	31.5	1.67	34.1	1.84
	70	17.5	0.91	21.2	1.10	23.8	1.26	26.5	1.42	29.6	1.59	31.5	1.71	34.1	1.93
	75	17.5	0.93	21.2	1.13	23.8	1.31	26.5	1.51	29.6	1.73	31.5	1.88	34.1	2.12
	80	17.5	0.96	21.2	1.20	23.8	1.40	26.5	1.62	29.6	1.86	31.5	2.02	34.1	2.28
	85	17.5	1.17	21.2	1.47	23.8	1.73	26.5	2.00	29.6	2.30	31.5	2.50	34.1	2.83
	90	17.5	1.17	21.2	1.47	23.8	1.73	26.5	2.00	29.6	2.30	31.5	2.50	34.1	2.83
95	17.5	1.24	21.2	1.57	23.8	1.85	26.5	2.14	29.6	2.46	31.5	2.68	34.1	3.04	
100	17.5	1.33	21.2	1.68	23.8	1.97	26.5	2.29	29.6	2.63	31.5	2.88	34.1	3.26	
105	17.5	1.44	21.2	1.80	23.8	2.12	26.5	2.46	29.6	2.85	31.5	3.11	34.1	3.51	
110	17.5	1.46	21.2	1.82	23.8	2.14	26.5	2.49	29.6	2.87	31.5	3.13	34.1	3.54	
115	17.5	1.47	21.2	1.84	23.8	2.16	26.5	2.51	29.6	2.90	31.5	2.90	34.1	3.57	

Capacity rated using ISO 5151—Test Rating Standard for Non-Ducted Heat Pumps.

Cooling mode stable operation is ensured when the outdoor ambient dry-bulb temperature is between 23°F and 115°F.

Rapid cooling operation is stable at indoor temperatures up to 80°F DB.

Power Input (PI) in kW and includes compressor(s) and outdoor fan motor(s).

Rated with an equivalent piping length of 24.6 ft. and no change in elevation between the indoor and outdoor unit.

MBh = Net Capacity

R410A, 60 Hz

Due to differences in test method and procedures, capacity data values provided in these tables may differ from certified performance information published by AHRI or other standardized testing agencies. AHRI testing protocol sets the volume of air flowing over the coil at 444 CFM/ton and limits the number of indoor units connected to the system being tested. LG conducts capacity tests using airflow rates and limits the number of indoor units per system as stated in Table 4 (a and b) on pages 17–18, Table 5 on page 19, and Table 14 on page 56.



Table 15a: ARUN036GS2 Heat Pump—Nominal Heating Capacity

Combination Ratio (%)	Outdoor Air Temp (°F)		Indoor Air Temperature (°F) DB															
			59		61		64		67		70		73		76		80	
	DB	WB	MBh	PI	MBh	PI	MBh	PI	MBh	PI	MBh	PI	MBh	PI	MBh	PI	MBh	PI
130	-4	-4.4	31.0	3.79	31.0	3.81	31.0	3.84	31.0	3.88	31.0	3.88	31.0	3.88	31.0	3.91	31.0	3.95
	0	-0.4	32.6	3.85	32.1	3.85	31.5	3.85	31.5	3.88	31.5	3.88	31.5	3.91	31.5	3.91	31.5	3.91
	5.0	4.5	35.2	3.85	35.2	3.88	35.2	3.91	35.2	3.91	35.2	3.95	35.2	3.95	35.2	3.98	35.2	4.01
	10.0	9.0	36.8	3.91	36.8	3.91	36.8	3.91	36.8	3.95	36.8	3.95	36.8	3.98	36.8	3.98	36.8	3.98
	15.0	14.0	39.9	3.95	39.9	3.95	39.9	3.95	39.3	3.98	39.3	3.98	39.3	4.01	39.3	4.01	39.3	4.01
	20.0	19.0	41.5	3.98	41.5	3.98	41.5	3.98	41.5	4.01	41.5	4.01	41.5	4.01	41.5	4.05	41.5	4.08
	25.0	23.0	44.7	4.00	44.7	4.00	44.7	4.00	44.7	4.04	44.7	4.04	44.7	4.08	44.7	4.08	44.7	4.08
	30.0	28.0	45.6	4.04	45.6	4.04	45.6	4.04	45.6	4.08	45.6	4.08	45.6	4.12	45.6	4.12	45.6	4.12
	35.0	32.0	47.8	4.08	47.8	4.08	47.8	4.08	47.8	4.12	47.8	4.12	47.8	4.16	47.8	4.08	47.8	4.00
	40.0	36.0	49.9	4.04	49.9	4.08	49.9	4.12	49.9	4.16	49.9	4.16	49.9	4.08	49.9	3.96	49.9	3.84
	45.0	41.0	52.5	4.08	51.9	4.12	51.4	4.16	51.4	4.06	51.4	4.04	51.4	3.96	51.4	3.79	51.4	3.64
	47.0	43.0	54.1	4.24	53.5	4.20	53.0	4.16	53.0	4.12	52.5	4.08	53.0	3.79	52.5	3.67	51.9	3.55
	50.0	46.0	55.1	4.21	55.1	4.08	55.1	3.96	55.1	3.79	55.1	3.75	55.1	3.67	52.5	3.51	50.0	3.35
	55.0	51.0	56.7	4.13	56.7	3.96	56.7	3.79	56.7	3.67	56.7	3.63	55.7	3.51	52.5	3.39	49.6	3.27
60.0	56.0	60.4	3.92	59.8	3.79	59.3	3.67	59.3	3.51	57.7	3.47	55.7	3.39	52.5	3.26	49.6	3.15	
120	-4	-4.4	30.2	3.76	30.2	3.78	30.2	3.80	30.2	3.84	30.2	3.84	30.2	3.85	30.2	3.88	30.2	3.91
	0	-0.4	31.8	3.82	30.7	3.82	29.7	3.82	29.7	3.85	29.7	3.85	29.7	3.88	29.7	3.88	29.7	3.88
	5.0	4.5	34.7	3.82	33.7	3.85	33.2	3.88	33.2	3.88	33.2	3.91	33.2	3.91	32.8	3.95	32.3	3.98
	10.0	9.0	36.7	3.88	35.7	3.88	34.7	3.88	34.7	3.91	34.7	3.91	34.7	3.95	34.7	3.95	34.7	3.95
	15.0	14.0	37.2	3.88	37.2	3.92	37.2	3.92	37.2	3.92	37.2	3.97	37.2	3.97	37.2	3.97	37.2	3.97
	20.0	19.0	39.1	3.88	39.1	3.91	39.1	3.95	39.1	3.95	39.1	3.98	39.1	3.98	39.1	4.01	39.1	4.05
	25.0	23.0	42.1	3.97	42.1	3.97	42.1	3.97	42.1	4.01	42.1	4.01	42.1	4.05	42.1	4.05	42.1	4.05
	30.0	28.0	43.1	4.01	43.1	4.01	43.1	4.01	43.1	4.05	43.1	4.05	43.1	4.09	43.1	4.09	43.1	4.09
	35.0	32.0	45.1	4.05	45.1	4.05	45.1	4.05	45.1	4.09	45.1	4.09	45.1	4.13	45.1	4.05	45.1	3.97
	40.0	36.0	47.1	4.01	47.1	4.05	47.1	4.09	47.1	4.13	47.1	4.13	47.1	4.05	47.1	3.92	47.1	3.81
	45.0	41.0	49.6	4.05	49.1	4.09	48.6	4.13	48.6	4.17	48.6	4.09	48.6	3.92	48.6	3.76	48.6	3.61
	47.0	43.0	51.0	4.21	50.6	4.13	50.1	4.05	50.1	3.92	49.6	4.05	50.1	3.76	49.6	3.64	49.1	3.52
	50.0	46.0	52.0	4.17	52.0	4.05	52.0	3.92	52.0	3.76	52.0	3.72	52.0	3.64	49.6	3.48	47.2	3.32
	55.0	51.0	53.5	4.09	53.5	3.92	53.5	3.76	53.5	3.64	53.5	3.60	52.5	3.48	49.6	3.36	46.7	3.24
60.0	56.0	57.0	3.89	56.5	3.76	56.0	3.64	56.0	3.48	54.5	3.44	52.5	3.36	49.6	3.24	46.7	3.12	
110	-4	-4.4	29.1	3.54	28.6	3.56	28.2	3.58	28.2	3.62	28.2	3.62	28.2	3.62	28.2	3.65	28.2	3.68
	0	-0.4	29.1	3.59	29.1	3.59	29.1	3.59	29.1	3.62	29.1	3.62	29.1	3.65	28.6	3.65	28.2	3.65
	5.0	4.5	32.4	3.59	32.4	3.62	32.4	3.65	32.4	3.65	32.4	3.68	32.4	3.68	32.4	3.72	32.4	3.75
	10.0	9.0	34.2	3.65	34.2	3.65	34.2	3.65	34.2	3.68	34.2	3.68	34.2	3.72	33.7	3.72	33.2	3.72
	15.0	14.0	36.5	3.68	36.5	3.68	36.5	3.68	36.5	3.72	36.5	3.69	36.5	3.75	36.5	3.75	36.5	3.75
	20.0	19.0	38.4	3.72	38.4	3.72	38.4	3.72	38.4	3.75	38.4	3.66	38.4	3.75	38.4	3.78	38.4	3.81
	25.0	23.0	40.2	3.73	40.2	3.73	40.2	3.73	40.2	3.73	40.2	3.77	40.2	3.81	40.2	3.81	40.2	3.81
	30.0	28.0	41.1	3.77	41.1	3.77	41.1	3.77	41.1	3.81	41.1	3.81	41.1	3.85	41.1	3.85	41.1	3.85
	35.0	32.0	42.0	3.81	42.0	3.81	42.0	3.81	42.0	3.85	42.0	3.85	42.0	3.88	41.6	3.81	41.1	3.73
	40.0	36.0	43.9	3.77	43.9	3.81	43.9	3.85	43.9	3.88	43.5	3.88	43.5	3.81	42.5	3.69	41.6	3.58
	45.0	41.0	46.2	3.81	45.7	3.85	45.2	3.88	45.2	3.85	45.2	3.85	44.9	3.69	42.5	3.54	40.3	3.40
	47.0	43.0	46.6	3.96	46.6	3.88	46.6	3.81	46.6	3.69	46.2	3.81	44.9	3.54	42.5	3.43	40.3	3.32
	50.0	46.0	48.5	3.93	48.5	3.81	48.5	3.69	48.5	3.54	46.6	3.50	44.9	3.43	42.5	3.27	40.3	3.13
	55.0	51.0	49.9	3.85	49.9	3.69	49.9	3.54	48.5	3.43	46.6	3.39	44.9	3.27	42.5	3.16	40.3	3.05
60.0	56.0	54.6	3.66	52.6	3.54	50.9	3.43	48.5	3.27	47.6	3.24	44.9	3.17	42.5	3.05	40.3	2.93	

Capacity rated using ISO 5151—Test Rating Standard for Non-Ducted Heat Pumps.
 Heating mode stable operation is ensured when the outdoor ambient wet-bulb temperature is between -4°F and 60°F.
 Power Input (PI) in kW and includes compressor(s) and outdoor fan motor(s).
 Rated with an equivalent piping length of 24.6 ft. and no change in elevation between the indoor and outdoor unit.
 MBh = Net Capacity
 R410A, 60 Hz

Due to differences in test method and procedures, capacity data values provided in these tables may differ from certified performance information published by AHRI or other standardized testing agencies. AHRI testing protocol sets the volume of air flowing over the coil at 444 CFM/ton and limits the number of indoor units connected to the system being tested. LG conducts capacity tests using airflow rates and limits the number of indoor units per system as stated in Table 4 (a and b) on pages 17–18, Table 5 on page 19, and Table 14 on page 56.

PERFORMANCE DATA



Heating Capacity—3.0 Ton

Table 15b: ARUN036GS2 Heat Pump—Nominal Heating Capacity

Combination Ratio (%)	Outdoor Air Temp (°F)		Indoor Air Temperature (°F) DB															
			59		61		64		67		70		73		76		80	
	DB	WB	MBh	PI	MBh	PI	MBh	PI	MBh	PI	MBh	PI	MBh	PI	MBh	PI	MBh	PI
100	-4	-4.4	28.1	3.98	28.1	4.08	28.1	4.18	28.1	4.22	27.7	4.25	27.7	4.25	27.7	4.25	27.7	4.25
	0	-0.4	29.0	4.15	29.0	4.18	29.0	4.22	29.0	4.25	29.0	4.28	28.5	4.28	28.5	4.28	28.5	4.28
	5.0	4.5	32.8	4.22	32.4	4.25	32.0	4.28	32.0	4.32	32.0	4.35	32.0	4.35	32.0	4.39	32.0	4.42
	10.0	9.0	34.0	4.28	34.0	4.32	34.0	4.35	33.6	4.35	33.6	4.39	33.6	4.39	33.6	4.25	33.6	4.12
	15.0	14.0	36.1	4.39	36.1	4.35	36.1	4.32	36.1	4.32	36.1	4.28	36.1	4.22	35.7	4.05	35.3	3.88
	20.0	19.0	38.3	4.39	38.3	4.32	38.3	4.25	38.3	4.15	37.3	4.05	37.3	3.91	36.8	3.88	36.2	3.84
	25.0	23.0	39.9	4.43	39.9	4.22	39.9	4.01	39.9	3.88	39.9	3.77	39.0	3.71	38.7	3.67	38.3	3.64
	30.0	28.0	40.7	4.12	40.7	4.01	40.7	3.91	40.7	3.74	40.7	3.71	39.9	3.67	38.7	3.64	37.4	3.60
	35.0	32.0	42.0	4.12	42.0	3.94	42.0	3.77	42.0	3.64	41.6	3.64	40.7	3.60	38.7	3.40	36.7	3.21
	40.0	36.0	43.7	4.02	43.7	3.88	43.7	3.74	43.7	3.57	42.0	3.47	40.7	3.40	38.7	3.20	36.7	3.00
	45.0	41.0	45.3	3.95	45.3	3.81	45.3	3.67	44.1	3.40	42.0	3.26	40.7	3.16	38.7	2.89	36.7	2.64
	47.0	43.0	47.0	3.96	46.6	3.74	46.2	3.54	44.1	3.26	42.0	3.40	40.7	3.03	38.7	2.79	36.7	2.57
50.0	46.0	50.5	3.75	48.3	3.57	46.2	3.40	44.1	3.06	42.0	3.03	40.7	2.92	38.7	2.69	36.7	2.47	
55.0	51.0	51.3	3.54	48.7	3.40	46.2	3.26	44.1	2.89	42.0	2.92	40.7	2.82	38.7	2.62	36.7	2.43	
60.0	56.0	51.3	3.51	48.7	3.33	46.2	3.16	44.1	2.79	42.0	2.82	40.7	2.72	38.7	2.52	36.7	2.33	
90	-4	-4.4	27.5	3.86	27.3	3.92	27.0	3.98	27.0	4.04	27.0	4.13	27.0	4.19	27.0	4.22	27.0	4.22
	0	-0.4	28.3	3.92	28.1	3.98	27.8	4.04	27.8	4.07	27.8	4.16	27.8	4.20	27.8	4.28	27.8	4.25
	5.0	4.5	31.3	3.98	31.3	4.04	31.3	4.10	31.3	4.13	31.3	4.19	31.0	4.22	31.0	4.31	31.0	4.40
	10.0	9.0	33.3	4.07	33.0	4.10	32.9	4.13	32.9	4.16	32.9	4.22	32.9	4.25	32.6	4.13	32.3	4.01
	15.0	14.0	35.4	3.89	35.4	3.80	35.4	3.71	35.2	3.65	35.2	3.53	35.2	3.47	33.0	3.74	31.1	4.03
	20.0	19.0	37.3	3.65	37.3	3.59	37.3	3.53	37.3	3.47	36.5	3.32	35.9	3.29	34.4	3.29	33.0	3.29
	25.0	23.0	39.7	3.66	39.7	3.47	39.7	3.29	39.0	3.23	37.8	3.20	36.7	3.20	34.8	3.11	33.0	3.02
	30.0	28.0	41.6	3.70	41.6	3.44	41.6	3.20	39.7	3.14	37.8	3.11	36.7	3.11	34.8	3.05	33.0	2.99
	35.0	32.0	42.3	3.74	42.0	3.41	41.6	3.11	39.7	3.08	37.8	3.05	36.7	3.05	34.8	2.99	33.0	2.93
	40.0	36.0	45.4	3.71	43.5	3.38	41.6	3.08	39.7	3.05	37.8	3.02	36.7	2.99	34.8	2.96	33.0	2.93
	45.0	41.0	46.2	3.68	43.9	3.35	41.6	3.05	39.7	3.02	37.8	3.01	36.7	2.96	34.8	2.90	33.0	2.84
	47.0	43.0	46.2	3.54	43.9	3.32	41.6	3.11	39.7	2.87	37.8	2.99	36.7	2.66	34.8	2.45	33.0	2.26
50.0	46.0	46.2	3.43	43.9	3.20	41.6	2.99	39.7	2.78	37.8	2.69	36.7	2.57	34.8	2.39	33.0	2.23	
55.0	51.0	46.2	3.31	43.9	3.08	41.6	2.87	39.7	2.69	37.8	2.57	36.7	2.48	34.8	2.30	33.0	2.14	
60.0	56.0	46.2	3.22	43.9	2.99	41.6	2.78	39.7	2.60	37.8	2.51	36.7	2.42	34.8	2.24	33.0	2.08	
80	-4	-4.4	27.5	3.40	27.0	3.46	26.6	3.51	26.6	3.56	26.6	3.61	26.6	3.67	26.6	3.69	26.6	3.72
	0	-0.4	27.8	3.46	27.8	3.51	27.8	3.56	27.8	3.59	27.8	3.67	27.8	3.69	27.5	3.72	27.3	3.74
	5.0	4.5	30.6	3.53	30.6	3.56	30.6	3.59	29.9	3.61	29.9	3.67	29.9	3.69	29.9	3.53	29.9	3.38
	10.0	9.0	32.9	3.35	32.9	3.40	32.9	3.46	32.9	3.59	32.6	3.67	31.6	3.69	30.9	3.38	30.3	3.09
	15.0	14.0	35.2	3.27	35.2	3.14	35.2	3.09	35.3	3.04	33.6	2.98	32.6	2.96	30.9	2.93	29.3	2.91
	20.0	19.0	36.6	3.22	36.3	3.09	36.3	2.97	35.3	2.92	33.6	2.90	32.6	2.88	30.9	2.83	29.3	2.79
	25.0	23.0	39.3	3.20	37.7	3.04	37.0	2.88	35.3	2.83	33.6	2.80	32.6	2.80	30.9	2.75	29.3	2.70
	30.0	28.0	41.1	3.21	39.0	3.01	37.0	2.83	35.3	2.78	33.6	2.75	32.6	2.72	30.9	2.67	29.3	2.62
	35.0	32.0	41.1	3.18	39.0	2.98	37.0	2.80	35.3	2.70	33.6	2.67	32.6	2.67	30.9	2.62	29.3	2.57
	40.0	36.0	41.1	3.15	39.0	2.96	37.0	2.78	35.3	2.67	33.6	2.64	32.6	2.62	30.9	2.57	29.3	2.51
	45.0	41.0	41.1	3.13	39.0	2.93	37.0	2.75	35.3	2.64	33.6	2.63	32.6	2.57	30.9	2.54	29.3	2.51
	47.0	43.0	41.1	3.10	39.0	2.91	37.0	2.72	35.3	2.51	33.6	2.62	32.6	2.36	30.9	2.17	29.3	2.00
50.0	46.0	41.1	3.00	39.0	2.80	37.0	2.62	35.3	2.43	33.6	2.36	32.6	2.28	30.9	2.09	29.3	1.93	
55.0	51.0	41.1	2.86	39.0	2.70	37.0	2.54	35.3	2.36	33.6	2.28	32.6	2.20	30.9	2.04	29.3	1.90	
60.0	56.0	41.1	2.82	39.0	2.62	37.0	2.43	35.3	2.28	33.6	2.20	32.6	2.12	30.9	1.96	29.3	1.82	

Capacity rated using ISO 5151—Test Rating Standard for Non-Ducted Heat Pumps.

Heating mode stable operation is ensured when the outdoor ambient wet-bulb temperature is between -4°F and 60°F.

Power Input (PI) in kW and includes compressor(s) and outdoor fan motor(s).

Rated with an equivalent piping length of 24.6 ft. and no change in elevation between the indoor and outdoor unit.

MBh = Net Capacity

R410A, 60 Hz

Due to differences in test method and procedures, capacity data values provided in these tables may differ from certified performance information published by AHRI or other standardized testing agencies. AHRI testing protocol sets the volume of air flowing over the coil at 444 CFM/ton and limits the number of indoor units connected to the system being tested. LG conducts capacity tests using airflow rates and limits the number of indoor units per system as stated in Table 4 (a and b) on pages 17–18, Table 5 on page 19, and Table 14 on page 56.



Table 15c: ARUN036GS2 Heat Pump—Nominal Heating Capacity

Combination Ratio (%)	Outdoor Air Temp (°F)		Indoor Air Temperature (°F) DB															
			59		61		64		67		70		73		76		80	
	DB	WB	MBh	PI	MBh	PI	MBh	PI	MBh	PI	MBh	PI	MBh	PI	MBh	PI	MBh	PI
70	-4	-4.4	26.2	3.39	26.2	3.39	25.9	3.42	25.9	3.46	25.9	3.42	25.9	3.39	25.0	3.45	23.2	3.36
	0	-0.4	27.0	3.44	27.0	3.42	27.0	3.46	26.8	3.49	26.8	3.49	26.8	3.42	25.3	3.50	23.5	3.38
	5.0	4.5	30.3	3.44	30.3	3.37	30.0	3.51	29.1	3.46	28.8	3.46	27.6	3.42	26.5	3.23	25.4	3.06
	10.0	9.0	32.4	3.33	32.9	3.12	31.5	3.12	30.9	3.37	29.4	3.37	28.5	3.31	27.0	3.04	25.7	2.79
	15.0	14.0	34.7	3.23	33.8	3.08	32.4	3.08	30.9	3.17	29.4	3.15	28.5	3.03	27.0	2.79	25.7	2.57
	20.0	19.0	36.0	3.19	34.1	3.05	32.4	3.05	30.9	3.07	29.4	2.96	28.5	2.84	27.0	2.62	25.7	2.42
	25.0	23.0	36.0	3.17	34.1	3.03	32.4	2.96	30.9	2.78	29.4	2.69	28.5	2.60	27.0	2.39	25.7	2.20
	30.0	28.0	36.0	3.14	34.1	2.98	32.4	2.80	30.9	2.60	29.4	2.51	28.5	2.41	27.0	2.23	25.7	2.06
	35.0	32.0	35.9	2.96	34.1	2.80	32.4	2.64	30.9	2.46	29.4	2.44	28.5	2.28	27.0	2.12	25.7	1.97
	40.0	36.0	36.0	2.91	34.1	2.71	32.4	2.53	30.9	2.37	29.4	2.35	28.5	2.19	27.0	2.03	25.7	1.88
	45.0	41.0	36.0	2.77	34.1	2.60	32.4	2.44	30.9	2.35	29.4	2.30	28.5	2.12	27.0	1.96	25.7	1.81
	47.0	43.0	36.0	2.68	34.1	2.51	32.4	2.35	30.9	2.21	29.4	2.28	28.5	2.05	27.0	1.91	25.7	1.79
	50.0	46.0	36.0	2.61	34.1	2.44	32.4	2.28	30.9	2.14	29.4	2.05	28.5	1.98	27.0	1.85	25.7	1.72
	55.0	51.0	36.0	2.49	34.1	2.35	32.4	2.21	30.9	2.07	29.4	1.98	28.5	1.91	27.0	1.78	25.7	1.65
60.0	56.0	36.0	2.42	34.1	2.28	32.4	2.14	30.9	2.00	29.4	1.94	28.5	1.87	27.0	1.73	25.7	1.60	
60	-4	-4.4	26.0	3.08	26.0	3.10	25.7	3.12	26.2	3.14	25.2	3.16	24.5	3.49	23.2	3.21	22.0	2.95
	0	-0.4	27.0	3.37	27.0	3.39	26.8	3.41	26.5	3.16	25.2	3.18	24.5	3.37	23.2	3.09	22.0	2.84
	5.0	4.5	30.2	3.41	29.2	3.58	27.7	3.43	26.5	3.18	25.2	3.06	24.5	2.94	23.2	2.71	22.0	2.50
	10.0	9.0	30.8	3.31	29.2	3.45	27.7	3.22	26.5	2.99	25.2	2.88	24.5	2.77	23.2	2.56	22.0	2.36
	15.0	14.0	30.8	3.22	29.2	3.16	27.7	2.95	26.5	2.75	25.2	2.65	24.5	2.55	23.2	2.36	22.0	2.17
	20.0	19.0	30.8	3.17	29.2	2.96	27.7	2.77	26.5	2.58	25.2	2.49	24.5	2.40	23.2	2.22	22.0	2.05
	25.0	23.0	30.8	2.88	29.2	2.69	27.7	2.52	26.5	2.36	25.2	2.27	24.5	2.19	23.2	2.03	22.0	1.89
	30.0	28.0	30.8	2.68	29.2	2.52	27.7	2.36	26.5	2.21	25.2	2.13	24.5	2.05	23.2	1.90	22.0	1.76
	35.0	32.0	30.8	2.51	29.2	2.36	27.7	2.23	26.5	2.07	25.2	2.05	24.5	1.94	23.2	1.80	22.0	1.68
	40.0	36.0	30.8	2.43	29.2	2.29	27.7	2.15	26.5	2.02	25.2	2.00	24.5	1.88	23.2	1.74	22.0	1.62
	45.0	41.0	30.8	2.35	29.2	2.21	27.7	2.07	26.5	1.98	25.2	1.96	24.5	1.80	23.2	1.69	22.0	1.58
	47.0	43.0	30.8	2.28	29.2	2.13	27.7	2.00	26.5	1.86	25.2	1.94	24.5	1.74	23.2	1.63	22.0	1.52
	50.0	46.0	30.8	2.18	29.2	2.05	27.7	1.94	26.5	1.82	25.2	1.76	24.5	1.71	23.2	1.59	22.0	1.48
	55.0	51.0	30.8	2.12	29.2	2.00	27.7	1.88	26.5	1.76	25.2	1.71	24.5	1.65	23.2	1.53	22.0	1.42
60.0	56.0	30.8	2.06	29.2	1.94	27.7	1.82	26.5	1.71	25.2	1.65	24.5	1.59	23.2	1.49	22.0	1.40	
50	-4	-4.4	25.7	3.04	24.4	3.04	23.1	3.02	22.0	3.02	21.0	2.91	20.4	2.80	19.3	2.58	18.3	2.38
	0	-0.4	25.7	3.20	24.4	3.36	23.1	3.14	22.0	2.92	21.0	2.81	20.4	2.70	19.3	2.49	18.3	2.30
	5.0	4.5	25.7	3.14	24.4	2.94	23.1	2.75	22.0	2.56	21.0	2.47	20.4	2.38	19.3	2.20	18.3	2.03
	10.0	9.0	25.7	2.96	24.4	2.77	23.1	2.59	22.0	2.42	21.0	2.33	20.4	2.25	19.3	2.08	18.3	1.92
	15.0	14.0	25.7	2.72	24.4	2.55	23.1	2.39	22.0	2.23	21.0	2.15	20.4	2.07	19.3	1.92	18.3	1.78
	20.0	19.0	25.7	2.34	24.4	2.39	23.1	2.25	22.0	2.10	21.0	2.03	20.4	1.96	19.3	1.82	18.3	1.69
	25.0	23.0	25.7	2.34	24.4	2.19	23.1	2.05	22.0	1.92	21.0	1.85	20.4	1.79	19.3	1.66	18.3	1.54
	30.0	28.0	25.7	2.16	24.4	2.05	23.1	1.93	22.0	1.81	21.0	1.74	20.4	1.69	19.3	1.57	18.3	1.45
	35.0	32.0	25.7	2.05	24.4	1.93	23.1	1.82	22.0	1.71	21.0	1.68	20.4	1.60	19.3	1.49	18.3	1.38
	40.0	36.0	25.7	1.99	24.4	1.87	23.1	1.76	22.0	1.65	21.0	1.63	20.4	1.55	19.3	1.44	18.3	1.33
	45.0	41.0	25.7	1.92	24.4	1.81	23.1	1.69	22.0	1.61	21.0	1.61	20.4	1.50	19.3	1.41	18.3	1.32
	47.0	43.0	25.7	1.84	24.4	1.74	23.1	1.65	22.0	1.55	21.0	1.60	20.4	1.45	19.3	1.36	18.3	1.27
	50.0	46.0	25.7	1.80	24.4	1.69	23.1	1.60	22.0	1.50	21.0	1.45	20.4	1.41	19.3	1.33	18.3	1.25
	55.0	51.0	25.7	1.75	24.4	1.65	23.1	1.55	22.0	1.45	21.0	1.42	20.4	1.37	19.3	1.28	18.3	1.19
60.0	56.0	25.7	1.70	24.4	1.60	23.1	1.50	22.0	1.42	21.0	1.37	20.4	1.33	19.3	1.25	18.3	1.17	

Capacity rated using ISO 5151—Test Rating Standard for Non-Ducted Heat Pumps.
 Heating mode stable operation is ensured when the outdoor ambient wet-bulb temperature is between -4°F and 60°F.
 Power Input (PI) in kW and includes compressor(s) and outdoor fan motor(s).
 Rated with an equivalent piping length of 24.6 ft. and no change in elevation between the indoor and outdoor unit.
 MBh = Net Capacity
 R410A, 60 Hz

Due to differences in test method and procedures, capacity data values provided in these tables may differ from certified performance information published by AHRI or other standardized testing agencies. AHRI testing protocol sets the volume of air flowing over the coil at 444 CFM/ton and limits the number of indoor units connected to the system being tested. LG conducts capacity tests using airflow rates and limits the number of indoor units per system as stated in Table 4 (a and b) on pages 17–18, Table 5 on page 19, and Table 14 on page 56.

PERFORMANCE DATA



Heating Capacity—4.0 Ton

Table 16a: ARUN047GS2 Heat Pump—Nominal Heating Capacity

Combination Ratio (%)	Outdoor Air Temp (°F)		Indoor Air Temperature (°F) DB															
			59		61		64		67		70		73		76c		80	
	DB	WB	MBh	PI	MBh	PI	MBh	PI	MBh	PI	MBh	PI	MBh	PI	MBh	PI	MBh	PI
130	-4	-4.4	39.8	4.79	39.8	4.82	39.8	4.86	39.8	4.91	39.8	4.91	39.8	4.91	39.8	4.95	39.8	5.00
	0	-0.4	41.9	4.87	41.2	4.87	40.5	4.87	40.5	4.91	40.5	4.91	40.5	4.95	40.5	4.95	40.5	4.95
	5.0	4.5	45.3	4.87	45.3	4.91	45.3	4.95	45.3	4.95	45.3	5.00	45.3	5.00	45.3	5.03	45.3	5.07
	10.0	9.0	47.3	4.95	47.3	4.95	47.3	4.95	47.3	5.00	47.3	5.00	47.3	5.03	47.3	5.03	47.3	5.03
	15.0	14.0	51.3	5.00	51.3	5.00	51.3	5.00	50.6	5.03	50.6	5.03	50.6	5.07	50.6	5.07	50.6	5.07
	20.0	19.0	53.4	5.03	53.4	5.03	53.4	5.03	53.4	5.07	53.4	5.07	53.4	5.07	53.4	5.12	53.4	5.16
	25.0	23.0	57.4	5.06	57.4	5.06	57.4	5.06	57.4	5.11	57.4	5.11	57.4	5.16	57.4	5.16	57.4	5.16
	30.0	28.0	58.7	5.11	58.7	5.11	58.7	5.11	58.7	5.16	58.7	5.16	58.7	5.21	58.7	5.21	58.7	5.21
	35.0	32.0	61.5	5.16	61.5	5.16	61.5	5.16	61.5	5.21	61.5	5.21	61.5	5.26	61.5	5.16	61.5	5.06
	40.0	36.0	64.1	5.11	64.1	5.16	64.1	5.21	64.1	5.26	64.1	5.26	64.1	5.16	64.1	5.01	64.1	4.86
	45.0	41.0	67.5	5.16	66.8	5.21	66.1	5.26	66.1	5.13	66.1	5.11	66.1	5.01	66.1	4.79	66.1	4.60
	47.0	43.0	69.6	5.36	68.8	5.31	68.2	5.26	68.2	5.21	67.5	5.16	68.2	4.79	67.5	4.64	66.8	4.49
50.0	46.0	70.8	5.32	70.8	5.16	70.8	5.01	70.8	4.79	70.8	4.74	70.8	4.64	67.5	4.44	64.2	4.24	
55.0	51.0	72.8	5.22	72.8	5.01	72.8	4.79	72.8	4.64	72.8	4.59	71.6	4.44	67.5	4.29	63.7	4.14	
60.0	56.0	77.6	4.96	76.9	4.79	76.3	4.64	76.3	4.44	74.2	4.39	71.6	4.29	67.5	4.12	63.7	3.98	
120	-4	-4.4	38.8	4.76	38.8	4.78	38.8	4.81	38.8	4.86	38.8	4.86	38.8	4.87	38.8	4.91	38.8	4.95
	0	-0.4	40.8	4.83	39.5	4.83	38.2	4.83	38.2	4.87	38.2	4.87	38.2	4.91	38.2	4.91	38.2	4.91
	5.0	4.5	44.6	4.83	43.4	4.87	42.7	4.91	42.7	4.91	42.7	4.95	42.7	4.95	42.1	5.00	41.5	5.03
	10.0	9.0	47.2	4.91	45.9	4.91	44.6	4.91	44.6	4.95	44.6	4.95	44.6	5.00	44.6	5.00	44.6	5.00
	15.0	14.0	47.8	4.91	47.8	4.96	47.8	4.96	47.8	4.96	47.8	5.02	47.8	5.02	47.8	5.02	47.8	5.02
	20.0	19.0	50.3	4.91	50.3	4.95	50.3	5.00	50.3	5.00	50.3	5.03	50.3	5.03	50.3	5.07	50.3	5.12
	25.0	23.0	54.1	5.02	54.1	5.02	54.1	5.02	54.1	5.07	54.1	5.07	54.1	5.12	54.1	5.12	54.1	5.12
	30.0	28.0	55.4	5.07	55.4	5.07	55.4	5.07	55.4	5.12	55.4	5.12	55.4	5.17	55.4	5.17	55.4	5.17
	35.0	32.0	58.0	5.12	58.0	5.12	58.0	5.12	58.0	5.17	58.0	5.17	58.0	5.22	58.0	5.12	58.0	5.02
	40.0	36.0	60.6	5.07	60.6	5.12	60.6	5.17	60.6	5.22	60.6	5.22	60.6	5.12	60.6	4.96	60.6	4.82
	45.0	41.0	63.7	5.12	63.1	5.17	62.5	5.22	62.5	5.27	62.5	5.17	62.5	4.96	62.5	4.76	62.5	4.57
	47.0	43.0	65.6	5.32	65.0	5.22	64.4	5.12	64.4	4.96	63.7	5.12	64.4	4.76	63.7	4.60	63.1	4.45
50.0	46.0	66.9	5.27	66.9	5.12	66.9	4.96	66.9	4.76	66.9	4.70	66.9	4.60	63.7	4.40	60.7	4.20	
55.0	51.0	68.8	5.17	68.8	4.96	68.8	4.76	68.8	4.60	68.8	4.55	67.5	4.40	63.7	4.25	60.1	4.10	
60.0	56.0	73.2	4.92	72.6	4.76	72.0	4.60	72.0	4.40	70.1	4.35	67.5	4.25	63.7	4.10	60.1	3.95	
110	-4	-4.4	37.4	4.48	36.8	4.50	36.3	4.53	36.3	4.58	36.3	4.58	36.3	4.58	36.3	4.62	36.3	4.65
	0	-0.4	37.4	4.54	37.4	4.54	37.4	4.54	37.4	4.58	37.4	4.58	37.4	4.62	36.8	4.62	36.3	4.62
	5.0	4.5	41.6	4.54	41.6	4.58	41.6	4.62	41.6	4.62	41.6	4.65	41.6	4.65	41.6	4.70	41.6	4.74
	10.0	9.0	44.0	4.62	44.0	4.62	44.0	4.62	44.0	4.65	44.0	4.65	44.0	4.70	43.4	4.70	42.7	4.70
	15.0	14.0	46.9	4.65	46.9	4.65	46.9	4.65	46.9	4.70	46.9	4.67	46.9	4.74	46.9	4.74	46.9	4.74
	20.0	19.0	49.3	4.70	49.3	4.70	49.3	4.70	49.3	4.74	49.3	4.63	49.3	4.74	49.3	4.78	49.3	4.82
	25.0	23.0	51.7	4.72	51.7	4.72	51.7	4.72	51.7	4.72	51.7	4.77	51.7	4.82	51.7	4.82	51.7	4.82
	30.0	28.0	52.9	4.77	52.9	4.77	52.9	4.77	52.9	4.82	52.9	4.82	52.9	4.87	52.9	4.87	52.9	4.87
	35.0	32.0	54.0	4.82	54.0	4.82	54.0	4.82	54.0	4.87	54.0	4.87	54.0	4.91	53.5	4.82	52.9	4.72
	40.0	36.0	56.4	4.77	56.4	4.82	56.4	4.87	56.4	4.91	55.9	4.91	55.9	4.82	54.6	4.67	53.5	4.53
	45.0	41.0	59.4	4.82	58.8	4.87	58.2	4.91	58.2	4.87	58.2	4.87	57.7	4.67	54.6	4.48	51.9	4.30
	47.0	43.0	59.9	5.01	59.9	4.91	59.9	4.82	59.9	4.67	59.4	4.82	57.7	4.48	54.6	4.34	51.9	4.20
50.0	46.0	62.3	4.97	62.3	4.82	62.3	4.67	62.3	4.48	59.9	4.43	57.7	4.34	54.6	4.14	51.9	3.96	
55.0	51.0	64.1	4.87	64.1	4.67	64.1	4.48	62.3	4.34	59.9	4.29	57.7	4.14	54.6	4.00	51.9	3.86	
60.0	56.0	70.2	4.63	67.7	4.48	65.4	4.34	62.3	4.14	61.2	4.10	57.7	4.01	54.6	3.86	51.9	3.71	

Capacity rated using ISO 5151—Test Rating Standard for Non-Ducted Heat Pumps.
 Heating mode stable operation is ensured when the outdoor ambient wet-bulb temperature is between -4°F and 60°F.
 Power Input (PI) in kW and includes compressor(s) and outdoor fan motor(s).
 Rated with an equivalent piping length of 24.6 ft. and no change in elevation between the indoor and outdoor unit.
 MBh = Net Capacity
 R410A, 60 Hz

Due to differences in test method and procedures, capacity data values provided in these tables may differ from certified performance information published by AHRI or other standardized testing agencies. AHRI testing protocol sets the volume of air flowing over the coil at 444 CFM/ton and limits the number of indoor units connected to the system being tested. LG conducts capacity tests using airflow rates and limits the number of indoor units per system as stated in Table 4 (a and b) on pages 17–18, Table 5 on page 19, and Table 14 on page 56.



Table 16b: ARUN047GS2 Heat Pump—Nominal Heating Capacity

Combination Ratio (%)	Outdoor Air Temp (°F)		Indoor Air Temperature (°F) DB															
			59		61		64		67		70		73		76		80	
	DB	WB	MBh	PI	MBh	PI	MBh	PI	MBh	PI	MBh	PI	MBh	PI	MBh	PI	MBh	PI
100	-4	-4.4	36.2	5.03	36.2	5.16	36.2	5.29	36.2	5.34	35.7	5.38	35.7	5.38	35.7	5.38	35.7	5.38
	0	-0.4	37.3	5.25	37.3	5.29	37.3	5.34	37.3	5.38	37.3	5.41	36.7	5.41	36.7	5.41	36.7	5.41
	5.0	4.5	42.1	5.34	41.6	5.38	41.1	5.41	41.1	5.46	41.1	5.50	41.1	5.50	41.1	5.55	41.1	5.59
	10.0	9.0	43.8	5.41	43.8	5.46	43.8	5.50	43.3	5.50	43.3	5.55	43.3	5.55	43.3	5.58	43.3	5.21
	15.0	14.0	46.4	5.55	46.4	5.50	46.4	5.46	46.4	5.46	46.4	5.41	46.4	5.34	45.9	5.12	45.4	4.91
	20.0	19.0	49.2	5.55	49.2	5.46	49.2	5.38	49.2	5.25	47.9	5.12	47.9	4.95	47.3	4.91	46.5	4.86
	25.0	23.0	51.3	5.60	51.3	5.34	51.3	5.07	51.3	4.91	51.3	4.77	50.2	4.69	49.7	4.64	49.2	4.60
	30.0	28.0	52.4	5.21	52.4	5.07	52.4	4.95	52.4	4.73	52.4	4.69	51.3	4.64	49.7	4.60	48.1	4.55
	35.0	32.0	54.0	5.21	54.0	4.98	54.0	4.77	54.0	4.60	53.5	4.60	52.4	4.55	49.7	4.30	47.2	4.06
	40.0	36.0	56.1	5.08	56.1	4.91	56.1	4.73	56.1	4.52	54.0	4.39	52.4	4.30	49.7	4.05	47.2	3.79
	45.0	41.0	58.3	5.00	58.3	4.82	58.3	4.64	56.7	4.30	54.0	4.12	52.4	4.00	49.7	3.66	47.2	3.34
	47.0	43.0	60.4	5.01	59.9	4.73	59.4	4.48	56.7	4.12	54.0	4.30	52.4	3.83	49.7	3.53	47.2	3.25
	50.0	46.0	64.9	4.74	62.1	4.52	59.4	4.30	56.7	3.87	54.0	3.83	52.4	3.69	49.7	3.40	47.2	3.12
	55.0	51.0	66.0	4.48	62.6	4.30	59.4	4.12	56.7	3.66	54.0	3.69	52.4	3.57	49.7	3.31	47.2	3.07
60.0	56.0	66.0	4.44	62.6	4.21	59.4	4.00	56.7	3.53	54.0	3.57	52.4	3.44	49.7	3.19	47.2	2.95	
90	-4	-4.4	35.4	4.88	35.2	4.96	34.8	5.03	34.8	5.11	34.8	5.22	34.8	5.30	34.8	5.34	34.8	5.34
	0	-0.4	36.4	4.96	36.2	5.03	35.8	5.11	35.8	5.15	35.8	5.26	35.8	5.31	35.8	5.41	35.8	5.38
	5.0	4.5	40.2	5.03	40.2	5.11	40.2	5.19	40.2	5.22	40.2	5.30	39.8	5.34	39.8	5.45	39.8	5.56
	10.0	9.0	42.9	5.15	42.5	5.19	42.2	5.22	42.2	5.26	42.2	5.34	42.2	5.38	41.9	5.22	41.5	5.07
	15.0	14.0	45.5	4.92	45.5	4.81	45.5	4.69	45.3	4.62	45.3	4.46	45.3	4.39	42.5	4.73	40.0	5.10
	20.0	19.0	47.9	4.62	47.9	4.54	47.9	4.46	47.9	4.39	46.9	4.20	46.2	4.16	44.3	4.16	42.4	4.16
	25.0	23.0	51.1	4.63	51.1	4.39	51.1	4.16	50.1	4.09	48.6	4.05	47.2	4.05	44.8	3.93	42.4	3.82
	30.0	28.0	53.5	4.68	53.5	4.35	53.5	4.05	51.1	3.97	48.6	3.93	47.2	3.93	44.8	3.86	42.4	3.78
	35.0	32.0	54.4	4.73	54.0	4.31	53.5	3.93	51.1	3.90	48.6	3.86	47.2	3.86	44.8	3.78	42.4	3.71
	40.0	36.0	58.4	4.69	55.9	4.27	53.5	3.90	51.1	3.86	48.6	3.82	47.2	3.78	44.8	3.74	42.4	3.71
	45.0	41.0	59.4	4.65	56.4	4.24	53.5	3.86	51.1	3.82	48.6	3.81	47.2	3.74	44.8	3.67	42.4	3.59
	47.0	43.0	59.4	4.48	56.4	4.20	53.5	3.93	51.1	3.63	48.6	3.78	47.2	3.36	44.8	3.10	42.4	2.86
	50.0	46.0	59.4	4.34	56.4	4.05	53.5	3.78	51.1	3.52	48.6	3.40	47.2	3.25	44.8	3.02	42.4	2.82
	55.0	51.0	59.4	4.19	56.4	3.90	53.5	3.63	51.1	3.40	48.6	3.25	47.2	3.14	44.8	2.91	42.4	2.71
60.0	56.0	59.4	4.07	56.4	3.78	53.5	3.52	51.1	3.29	48.6	3.17	47.2	3.06	44.8	2.83	42.4	2.63	
80	-4	-4.4	35.4	4.30	34.8	4.38	34.1	4.44	34.1	4.50	34.1	4.57	34.1	4.64	34.1	4.67	34.1	4.70
	0	-0.4	35.8	4.38	35.8	4.44	35.8	4.50	35.8	4.54	35.8	4.64	35.8	4.67	35.4	4.70	35.2	4.73
	5.0	4.5	39.3	4.46	39.3	4.50	39.3	4.54	38.4	4.57	38.4	4.64	38.4	4.67	38.4	4.46	38.4	4.27
	10.0	9.0	42.2	4.24	42.2	4.30	42.2	4.38	42.2	4.54	41.9	4.64	40.6	4.67	39.7	4.27	39.0	3.91
	15.0	14.0	45.3	4.14	45.3	3.97	45.3	3.91	45.4	3.84	43.3	3.77	41.9	3.74	39.7	3.71	37.7	3.68
	20.0	19.0	47.0	4.07	46.7	3.91	46.7	3.76	45.4	3.69	43.3	3.67	41.9	3.64	39.7	3.58	37.7	3.53
	25.0	23.0	50.6	4.05	48.4	3.84	47.6	3.64	45.4	3.58	43.3	3.54	41.9	3.54	39.7	3.48	37.7	3.41
	30.0	28.0	52.9	4.06	50.1	3.81	47.6	3.58	45.4	3.52	43.3	3.48	41.9	3.44	39.7	3.38	37.7	3.31
	35.0	32.0	52.9	4.02	50.1	3.77	47.6	3.54	45.4	3.41	43.3	3.38	41.9	3.38	39.7	3.31	37.7	3.25
	40.0	36.0	52.9	3.98	50.1	3.74	47.6	3.52	45.4	3.38	43.3	3.34	41.9	3.31	39.7	3.25	37.7	3.17
	45.0	41.0	52.9	3.96	50.1	3.71	47.6	3.48	45.4	3.34	43.3	3.33	41.9	3.25	39.7	3.21	37.7	3.17
	47.0	43.0	52.9	3.92	50.1	3.68	47.6	3.44	45.4	3.17	43.3	3.31	41.9	2.98	39.7	2.74	37.7	2.53
	50.0	46.0	52.9	3.79	50.1	3.54	47.6	3.31	45.4	3.07	43.3	2.98	41.9	2.88	39.7	2.64	37.7	2.44
	55.0	51.0	52.9	3.62	50.1	3.41	47.6	3.21	45.4	2.98	43.3	2.88	41.9	2.78	39.7	2.58	37.7	2.40
60.0	56.0	52.9	3.57	50.1	3.31	47.6	3.07	45.4	2.88	43.3	2.78	41.9	2.68	39.7	2.48	37.7	2.30	

Capacity rated using ISO 5151—Test Rating Standard for Non-Ducted Heat Pumps.
 Heating mode stable operation is ensured when the outdoor ambient wet-bulb temperature is between -4°F and 60°F.
 Power Input (PI) in kW and includes compressor(s) and outdoor fan motor(s).
 Rated with an equivalent piping length of 24.6 ft. and no change in elevation between the indoor and outdoor unit.
 MBh = Net Capacity
 R410A, 60 Hz

Due to differences in test method and procedures, capacity data values provided in these tables may differ from certified performance information published by AHRI or other standardized testing agencies. AHRI testing protocol sets the volume of air flowing over the coil at 444 CFM/ton and limits the number of indoor units connected to the system being tested. LG conducts capacity tests using airflow rates and limits the number of indoor units per system as stated in Table 4 (a and b) on pages 17–18, Table 5 on page 19, and Table 14 on page 56.

MULTI V
MINI
HEAT PUMP CONDENSING UNIT ENGINEERING MANUAL

PERFORMANCE DATA



Heating Capacity—4.0 Ton

Table 16c: ARUN047GS2 Heat Pump—Nominal Heating Capacity

Combination Ratio (%)	Outdoor Air Temp (°F) DB		Indoor Air Temperature (°F) DB															
			59		61		64		67		70		73		76		80	
	DB	WB	MBh	PI	MBh	PI	MBh	PI	MBh	PI	MBh	PI	MBh	PI	MBh	PI	MBh	PI
70	-4	-4.4	33.6	4.29	33.6	4.29	33.3	4.33	33.3	4.38	33.3	4.33	33.3	4.29	32.1	4.36	29.8	4.25
	0	-0.4	34.8	4.35	34.8	4.33	34.8	4.38	34.4	4.41	34.4	4.41	34.4	4.33	32.5	4.43	30.2	4.27
	5.0	4.5	39.0	4.35	39.0	4.26	38.6	4.44	37.4	4.38	37.1	4.38	35.5	4.33	34.0	4.09	32.6	3.87
	10.0	9.0	41.6	4.21	42.2	3.95	40.5	3.95	39.7	4.26	37.8	4.26	36.7	4.19	34.8	3.84	33.0	3.53
	15.0	14.0	44.6	4.09	43.5	3.90	41.6	3.90	39.7	4.01	37.8	3.98	36.7	3.83	34.8	3.53	33.0	3.25
	20.0	19.0	46.3	4.03	43.9	3.86	41.6	3.86	39.7	3.88	37.8	3.74	36.7	3.59	34.8	3.31	33.0	3.06
	25.0	23.0	46.3	4.01	43.9	3.83	41.6	3.74	39.7	3.52	37.8	3.40	36.7	3.29	34.8	3.02	33.0	2.78
	30.0	28.0	46.3	3.97	43.9	3.77	41.6	3.54	39.7	3.29	37.8	3.17	36.7	3.05	34.8	2.82	33.0	2.61
	35.0	32.0	46.2	3.74	43.9	3.54	41.6	3.34	39.7	3.11	37.8	3.09	36.7	2.88	34.8	2.68	33.0	2.49
	40.0	36.0	46.3	3.68	43.9	3.43	41.6	3.20	39.7	3.00	37.8	2.97	36.7	2.77	34.8	2.57	33.0	2.38
	45.0	41.0	46.3	3.50	43.9	3.29	41.6	3.09	39.7	2.97	37.8	2.91	36.7	2.68	34.8	2.48	33.0	2.29
	60	47.0	43.0	46.3	3.39	43.9	3.17	41.6	2.97	39.7	2.80	37.8	2.88	36.7	2.59	34.8	2.42	33.0
50.0		46.0	46.3	3.30	43.9	3.09	41.6	2.88	39.7	2.71	37.8	2.59	36.7	2.50	34.8	2.34	33.0	2.18
55.0		51.0	46.3	3.15	43.9	2.97	41.6	2.80	39.7	2.62	37.8	2.50	36.7	2.42	34.8	2.25	33.0	2.09
60.0		56.0	46.3	3.06	43.9	2.88	41.6	2.71	39.7	2.53	37.8	2.45	36.7	2.37	34.8	2.19	33.0	2.02
-4		-4.4	33.4	3.90	33.4	3.92	33.0	3.95	33.6	3.97	32.4	4.00	31.5	4.41	29.8	4.06	28.3	3.73
0		-0.4	34.7	4.26	34.7	4.29	34.4	4.31	34.0	4.00	32.4	4.02	31.5	4.26	29.8	3.91	28.3	3.59
5.0		4.5	38.8	4.31	37.6	4.53	35.7	4.34	34.0	4.02	32.4	3.87	31.5	3.72	29.8	3.43	28.3	3.16
10.0		9.0	39.6	4.19	37.6	4.36	35.7	4.07	34.0	3.78	32.4	3.64	31.5	3.50	29.8	3.24	28.3	2.98
15.0		14.0	39.6	4.07	37.6	4.00	35.7	3.73	34.0	3.48	32.4	3.35	31.5	3.23	29.8	2.98	28.3	2.74
20.0		19.0	39.6	4.01	37.6	3.74	35.7	3.50	34.0	3.26	32.4	3.15	31.5	3.04	29.8	2.81	28.3	2.59
25.0		23.0	39.6	3.64	37.6	3.40	35.7	3.19	34.0	2.98	32.4	2.87	31.5	2.77	29.8	2.57	28.3	2.39
30.0		28.0	39.6	3.39	37.6	3.19	35.7	2.98	34.0	2.80	32.4	2.69	31.5	2.59	29.8	2.40	28.3	2.23
35.0	32.0	39.6	3.17	37.6	2.98	35.7	2.82	34.0	2.62	32.4	2.59	31.5	2.45	29.8	2.28	28.3	2.12	
40.0	36.0	39.6	3.07	37.6	2.90	35.7	2.72	34.0	2.55	32.4	2.53	31.5	2.38	29.8	2.20	28.3	2.05	
45.0	41.0	39.6	2.97	37.6	2.80	35.7	2.62	34.0	2.50	32.4	2.48	31.5	2.28	29.8	2.14	28.3	2.00	
50.0	46.0	39.6	2.88	37.6	2.69	35.7	2.53	34.0	2.35	32.4	2.45	31.5	2.20	29.8	2.06	28.3	1.92	
55.0	51.0	39.6	2.76	37.6	2.59	35.7	2.45	34.0	2.30	32.4	2.23	31.5	2.16	29.8	2.01	28.3	1.87	
60.0	56.0	39.6	2.61	37.6	2.45	35.7	2.30	34.0	2.16	32.4	2.09	31.5	2.01	29.8	1.88	28.3	1.77	
50	-4	-4.4	33.0	3.84	31.4	3.84	29.7	3.82	28.3	3.82	27.1	3.68	26.2	3.54	24.8	3.26	23.5	3.01
	0	-0.4	33.0	4.05	31.4	4.25	29.7	3.97	28.3	3.69	27.1	3.55	26.2	3.41	24.8	3.15	23.5	2.91
	5.0	4.5	33.0	3.97	31.4	3.72	29.7	3.48	28.3	3.24	27.1	3.12	26.2	3.01	24.8	2.78	23.5	2.57
	10.0	9.0	33.0	3.74	31.4	3.50	29.7	3.28	28.3	3.06	27.1	2.95	26.2	2.85	24.8	2.63	23.5	2.43
	15.0	14.0	33.0	3.44	31.4	3.23	29.7	3.02	28.3	2.82	27.1	2.72	26.2	2.62	24.8	2.43	23.5	2.25
	20.0	19.0	33.0	2.96	31.4	3.02	29.7	2.85	28.3	2.66	27.1	2.57	26.2	2.48	24.8	2.30	23.5	2.14
	25.0	23.0	33.0	2.96	31.4	2.77	29.7	2.59	28.3	2.43	27.1	2.34	26.2	2.26	24.8	2.10	23.5	1.95
	30.0	28.0	33.0	2.73	31.4	2.59	29.7	2.44	28.3	2.29	27.1	2.20	26.2	2.14	24.8	1.99	23.5	1.83
	35.0	32.0	33.0	2.59	31.4	2.44	29.7	2.30	28.3	2.16	27.1	2.12	26.2	2.02	24.8	1.88	23.5	1.75
	40.0	36.0	33.0	2.52	31.4	2.37	29.7	2.23	28.3	2.09	27.1	2.06	26.2	1.96	24.8	1.82	23.5	1.68
	45.0	41.0	33.0	2.43	31.4	2.29	29.7	2.14	28.3	2.04	27.1	2.04	26.2	1.90	24.8	1.78	23.5	1.67
	47.0	43.0	33.0	2.33	31.4	2.20	29.7	2.09	28.3	1.96	27.1	2.02	26.2	1.83	24.8	1.72	23.5	1.61
50.0	46.0	33.0	2.28	31.4	2.14	29.7	2.02	28.3	1.90	27.1	1.83	26.2	1.78	24.8	1.68	23.5	1.58	
55.0	51.0	33.0	2.21	31.4	2.09	29.7	1.96	28.3	1.83	27.1	1.80	26.2	1.73	24.8	1.62	23.5	1.51	
60.0	56.0	33.0	2.15	31.4	2.02	29.7	1.90	28.3	1.80	27.1	1.73	26.2	1.68	24.8	1.58	23.5	1.48	

Capacity rated using ISO 5151—Test Rating Standard for Non-Ducted Heat Pumps.
 Heating mode stable operation is ensured when the outdoor ambient wet-bulb temperature is between -4°F and 60°F.
 Power Input (PI) in kW and includes compressor(s) and outdoor fan motor(s).
 Rated with an equivalent piping length of 24.6 ft. and no change in elevation between the indoor and outdoor unit.
 MBh = Net Capacity
 R410A, 60 Hz

Due to differences in test method and procedures, capacity data values provided in these tables may differ from certified performance information published by AHRI or other standardized testing agencies. AHRI testing protocol sets the volume of air flowing over the coil at 444 CFM/ton and limits the number of indoor units connected to the system being tested. LG conducts capacity tests using airflow rates and limits the number of indoor units per system as stated in Table 4 (a and b) on pages 17–18, Table 5 on page 19, and Table 14 on page 56.



Table 17a: ARUN053GS2 Heat Pump—Nominal Heating Capacity

Combination Ratio (%)	Outdoor Air Temp (°F) DB		Indoor Air Temperature (°F) DB															
			59		61		64		67		70		73		76		80	
	DB	WB	MBh	PI	MBh	PI	MBh	PI	MBh	PI	MBh	PI	MBh	PI	MBh	PI	MBh	PI
130	-4	-4.4	45.0	6.24	45.0	6.28	45.0	6.32	45.0	6.39	45.0	6.39	45.0	6.39	45.0	6.44	45.0	6.51
	0	-0.4	47.3	6.34	46.6	6.34	45.7	6.34	45.7	6.39	45.7	6.39	45.7	6.44	45.7	6.44	45.7	6.44
	5.0	4.5	51.1	6.34	51.1	6.39	51.1	6.44	51.1	6.44	51.1	6.51	51.1	6.51	51.1	6.56	51.1	6.60
	10.0	9.0	53.4	6.44	53.4	6.44	53.4	6.44	53.4	6.51	53.4	6.51	53.4	6.56	53.4	6.56	53.4	6.56
	15.0	14.0	58.0	6.51	58.0	6.51	58.0	6.51	57.1	6.56	57.1	6.56	57.1	6.60	57.1	6.60	57.1	6.60
	20.0	19.0	60.3	6.56	60.3	6.56	60.3	6.56	60.3	6.60	60.3	6.60	60.3	6.60	60.3	6.60	60.3	6.67
	25.0	23.0	64.9	6.59	64.9	6.59	64.9	6.59	64.9	6.65	64.9	6.65	64.9	6.72	64.9	6.72	64.9	6.72
	30.0	28.0	66.3	6.65	66.3	6.65	66.3	6.65	66.3	6.72	66.3	6.72	66.3	6.79	66.3	6.79	66.3	6.79
	35.0	32.0	69.4	6.72	69.4	6.72	69.4	6.72	69.4	6.79	69.4	6.79	69.4	6.85	69.4	6.72	69.4	6.59
	40.0	36.0	72.4	6.65	72.4	6.72	72.4	6.79	72.4	6.85	72.4	6.85	72.4	6.72	72.4	6.52	72.4	6.32
	45.0	41.0	76.3	6.72	75.4	6.79	74.7	6.85	74.7	6.69	74.7	6.65	74.7	6.52	74.7	6.24	74.7	6.00
	47.0	43.0	78.6	6.98	77.7	6.92	77.0	6.85	77.0	6.79	76.3	6.72	77.0	6.24	76.3	6.04	75.4	5.85
50.0	46.0	80.0	6.93	80.0	6.72	80.0	6.52	80.0	6.24	80.0	6.18	80.0	6.04	76.3	5.78	72.6	5.52	
55.0	51.0	82.3	6.80	82.3	6.52	82.3	6.24	82.3	6.04	82.3	5.98	80.9	5.78	76.3	5.58	72.0	5.39	
60.0	56.0	87.7	6.46	86.9	6.24	86.1	6.04	86.1	5.78	83.9	5.72	80.9	5.58	76.3	5.37	72.0	5.19	
120	-4	-4.4	43.9	6.19	43.9	6.23	43.9	6.26	43.9	6.32	43.9	6.32	43.9	6.34	43.9	6.39	43.9	6.44
	0	-0.4	46.1	6.29	44.6	6.29	43.1	6.29	43.1	6.34	43.1	6.34	43.1	6.39	43.1	6.39	43.1	6.39
	5.0	4.5	50.4	6.29	49.0	6.34	48.3	6.39	48.3	6.39	48.3	6.44	48.3	6.44	47.6	6.51	46.9	6.56
	10.0	9.0	53.3	6.39	51.9	6.39	50.4	6.39	50.4	6.44	50.4	6.44	50.4	6.51	50.4	6.51	50.4	6.51
	15.0	14.0	54.0	6.39	54.0	6.46	54.0	6.46	54.0	6.46	54.0	6.54	54.0	6.54	54.0	6.54	54.0	6.54
	20.0	19.0	56.9	6.39	56.9	6.44	56.9	6.51	56.9	6.51	56.9	6.56	56.9	6.56	56.9	6.60	56.9	6.67
	25.0	23.0	61.1	6.54	61.1	6.54	61.1	6.54	61.1	6.60	61.1	6.60	61.1	6.67	61.1	6.67	61.1	6.67
	30.0	28.0	62.6	6.60	62.6	6.60	62.6	6.60	62.6	6.67	62.6	6.67	62.6	6.74	62.6	6.74	62.6	6.74
	35.0	32.0	65.6	6.67	65.6	6.67	65.6	6.67	65.6	6.74	65.6	6.74	65.6	6.80	65.6	6.67	65.6	6.54
	40.0	36.0	68.4	6.60	68.4	6.67	68.4	6.74	68.4	6.80	68.4	6.80	68.4	6.67	68.4	6.46	68.4	6.28
	45.0	41.0	72.0	6.67	71.3	6.74	70.6	6.80	70.6	6.87	70.6	6.74	70.6	6.46	70.6	6.19	70.6	5.95
	47.0	43.0	74.1	6.93	73.4	6.80	72.7	6.67	72.7	6.46	72.0	6.67	72.7	6.19	72.0	6.00	71.3	5.80
50.0	46.0	75.6	6.87	75.6	6.67	75.6	6.46	75.6	6.19	75.6	6.13	75.6	6.00	72.0	5.73	68.6	5.47	
55.0	51.0	77.7	6.74	77.7	6.46	77.7	6.19	77.7	6.00	77.7	5.93	76.3	5.73	72.0	5.53	67.9	5.34	
60.0	56.0	82.7	6.41	82.0	6.19	81.3	6.00	81.3	5.73	79.1	5.67	76.3	5.53	72.0	5.34	67.9	5.14	
110	-4	-4.4	42.3	5.83	41.6	5.86	41.0	5.90	41.0	5.96	41.0	5.96	41.0	5.96	41.0	6.01	41.0	6.06
	0	-0.4	42.3	5.91	42.3	5.91	42.3	5.91	42.3	5.96	42.3	5.96	42.3	6.01	41.6	6.01	41.0	6.01
	5.0	4.5	47.0	5.91	47.0	5.96	47.0	6.01	47.0	6.01	47.0	6.06	47.0	6.06	47.0	6.13	47.0	6.18
	10.0	9.0	49.7	6.01	49.7	6.01	49.7	6.01	49.7	6.06	49.7	6.06	49.7	6.13	49.0	6.13	48.3	6.13
	15.0	14.0	53.0	6.06	53.0	6.06	53.0	6.06	53.0	6.13	53.0	6.08	53.0	6.18	53.0	6.18	53.0	6.18
	20.0	19.0	55.7	6.13	55.7	6.13	55.7	6.13	55.7	6.18	55.7	6.03	55.7	6.18	55.7	6.23	55.7	6.28
	25.0	23.0	58.4	6.14	58.4	6.14	58.4	6.14	58.4	6.14	58.4	6.21	58.4	6.28	58.4	6.28	58.4	6.28
	30.0	28.0	59.7	6.21	59.7	6.21	59.7	6.21	59.7	6.28	59.7	6.28	59.7	6.34	59.7	6.34	59.7	6.34
	35.0	32.0	61.0	6.28	61.0	6.28	61.0	6.28	61.0	6.34	61.0	6.34	61.0	6.39	60.4	6.28	59.7	6.14
	40.0	36.0	63.7	6.21	63.7	6.28	63.7	6.34	63.7	6.39	63.1	6.39	63.1	6.28	61.7	6.08	60.4	5.90
	45.0	41.0	67.1	6.28	66.4	6.34	65.7	6.39	65.7	6.34	65.7	6.34	65.1	6.08	61.7	5.83	58.6	5.60
	47.0	43.0	67.7	6.52	67.7	6.39	67.7	6.28	67.7	6.08	67.1	6.28	65.1	5.83	61.7	5.65	58.6	5.47
50.0	46.0	70.4	6.47	70.4	6.28	70.4	6.08	70.4	5.83	67.7	5.76	65.1	5.65	61.7	5.39	58.6	5.16	
55.0	51.0	72.4	6.34	72.4	6.08	72.4	5.83	70.4	5.65	67.7	5.58	65.1	5.39	61.7	5.20	58.6	5.02	
60.0	56.0	79.3	6.03	76.4	5.83	73.9	5.65	70.4	5.39	69.1	5.34	65.1	5.22	61.7	5.02	58.6	4.83	

Capacity rated using ISO 5151—Test Rating Standard for Non-Ducted Heat Pumps.
 Heating mode stable operation is ensured when the outdoor ambient wet-bulb temperature is between -4°F and 60°F.
 Power Input (PI) in kW and includes compressor(s) and outdoor fan motor(s).
 Rated with an equivalent piping length of 24.6 ft. and no change in elevation between the indoor and outdoor unit.
 MBh = Net Capacity
 R410A, 60 Hz

Due to differences in test method and procedures, capacity data values provided in these tables may differ from certified performance information published by AHRI or other standardized testing agencies. AHRI testing protocol sets the volume of air flowing over the coil at 444 CFM/ton and limits the number of indoor units connected to the system being tested. LG conducts capacity tests using airflow rates and limits the number of indoor units per system as stated in Table 4 (a and b) on pages 17–18, Table 5 on page 19, and Table 14 on page 56.

PERFORMANCE DATA



Heating Capacity—4.4 Ton

Table 17b: ARUN053GS2 Heat Pump—Nominal Heating Capacity

Combination Ratio (%)	Outdoor Air Temp (°F)		Indoor Air Temperature (°F) DB															
			59		61		64		67		70		73		76		80	
	DB	WB	MBh	PI	MBh	PI	MBh	PI	MBh	PI	MBh	PI	MBh	PI	MBh	PI	MBh	PI
100	-4	-4.4	40.9	6.56	40.9	6.72	40.9	6.88	40.9	6.95	40.3	7.00	40.3	7.00	40.3	7.00	40.3	7.00
	0	-0.4	42.1	6.84	42.1	6.88	42.1	6.95	42.1	7.00	42.1	7.05	41.4	7.05	41.4	7.05	41.4	7.05
	5.0	4.5	47.6	6.95	47.0	7.00	46.4	7.05	46.4	7.12	46.4	7.16	46.4	7.16	46.4	7.23	46.4	7.28
	10.0	9.0	49.4	7.05	49.4	7.12	49.4	7.16	48.9	7.16	48.9	7.23	48.9	7.23	48.9	7.00	48.9	6.79
	15.0	14.0	52.4	7.23	52.4	7.16	52.4	7.12	52.4	7.12	52.4	7.05	52.4	6.95	51.9	6.67	51.3	6.39
	20.0	19.0	55.6	7.23	55.6	7.12	55.6	7.00	55.6	6.84	54.1	6.67	54.1	6.44	53.4	6.39	52.6	6.32
	25.0	23.0	58.0	7.30	58.0	6.95	58.0	6.60	58.0	6.39	58.0	6.21	56.7	6.11	56.1	6.04	55.6	6.00
	30.0	28.0	59.1	6.79	59.1	6.60	59.1	6.44	59.1	6.16	59.1	6.11	58.0	6.04	56.1	6.00	54.3	5.93
	35.0	32.0	61.0	6.79	61.0	6.49	61.0	6.21	61.0	6.00	60.4	6.00	59.1	5.93	56.1	5.60	53.3	5.29
	40.0	36.0	63.4	6.62	63.4	6.39	63.4	6.16	63.4	5.88	61.0	5.72	59.1	5.60	56.1	5.27	53.3	4.94
	45.0	41.0	65.9	6.51	65.9	6.28	65.9	6.04	64.0	5.60	61.0	5.37	59.1	5.20	56.1	4.76	53.3	4.35
	47.0	43.0	68.3	6.52	67.7	6.16	67.1	5.83	64.0	5.37	61.0	5.60	59.1	4.99	56.1	4.60	53.3	4.23
	50.0	46.0	73.3	6.18	70.1	5.88	67.1	5.60	64.0	5.04	61.0	4.99	59.1	4.81	56.1	4.43	53.3	4.07
	55.0	51.0	74.6	5.83	70.7	5.60	67.1	5.37	64.0	4.76	61.0	4.81	59.1	4.64	56.1	4.32	53.3	4.00
60.0	56.0	74.6	5.78	70.7	5.48	67.1	5.20	64.0	4.60	61.0	4.64	59.1	4.48	56.1	4.15	53.3	3.84	
90	-4	-4.4	40.0	6.36	39.7	6.46	39.3	6.56	39.3	6.65	39.3	6.80	39.3	6.90	39.3	6.95	39.3	6.95
	0	-0.4	41.1	6.46	40.9	6.56	40.4	6.65	40.4	6.70	40.4	6.85	40.4	6.92	40.4	7.05	40.4	7.00
	5.0	4.5	45.4	6.56	45.4	6.65	45.4	6.75	45.4	6.80	45.4	6.90	45.0	6.95	45.0	7.10	45.0	7.25
	10.0	9.0	48.4	6.70	48.0	6.75	47.7	6.80	47.7	6.85	47.7	6.95	47.7	7.00	47.3	6.80	46.9	6.60
	15.0	14.0	51.4	6.41	51.4	6.26	51.4	6.11	51.1	6.01	51.1	5.81	51.1	5.72	48.0	6.16	45.1	6.64
	20.0	19.0	54.1	6.01	54.1	5.91	54.1	5.81	54.1	5.72	53.0	5.47	52.1	5.42	50.0	5.42	47.9	5.42
	25.0	23.0	57.7	6.03	57.7	5.72	57.7	5.42	56.6	5.32	54.9	5.27	53.3	5.27	50.6	5.12	47.9	4.97
	30.0	28.0	60.4	6.09	60.4	5.67	60.4	5.27	57.7	5.17	54.9	5.12	53.3	5.12	50.6	5.02	47.9	4.92
	35.0	32.0	61.4	6.16	61.0	5.62	60.4	5.12	57.7	5.07	54.9	5.02	53.3	5.02	50.6	4.92	47.9	4.83
	40.0	36.0	66.0	6.11	63.1	5.57	60.4	5.07	57.7	5.02	54.9	4.97	53.3	4.92	50.6	4.88	47.9	4.83
	45.0	41.0	67.1	6.06	63.7	5.52	60.4	5.02	57.7	4.97	54.9	4.96	53.3	4.88	50.6	4.78	47.9	4.68
	47.0	43.0	67.1	5.83	63.7	5.47	60.4	5.12	57.7	4.73	54.9	4.92	53.3	4.38	50.6	4.04	47.9	3.72
	50.0	46.0	67.1	5.65	63.7	5.27	60.4	4.92	57.7	4.58	54.9	4.43	53.3	4.23	50.6	3.94	47.9	3.67
	55.0	51.0	67.1	5.45	63.7	5.07	60.4	4.73	57.7	4.43	54.9	4.23	53.3	4.08	50.6	3.79	47.9	3.52
60.0	56.0	67.1	5.30	63.7	4.92	60.4	4.58	57.7	4.28	54.9	4.13	53.3	3.99	50.6	3.69	47.9	3.43	
80	-4	-4.4	40.0	5.60	39.3	5.70	38.6	5.78	38.6	5.86	38.6	5.95	38.6	6.04	38.6	6.08	38.6	6.13
	0	-0.4	40.4	5.70	40.4	5.78	40.4	5.86	40.4	5.91	40.4	6.04	40.4	6.08	40.0	6.13	39.7	6.16
	5.0	4.5	44.4	5.81	44.4	5.86	44.4	5.91	43.4	5.95	43.4	6.04	43.4	6.08	43.4	5.81	43.4	5.57
	10.0	9.0	47.7	5.52	47.7	5.60	47.7	5.70	47.7	5.91	47.3	6.04	45.9	6.08	44.9	5.57	44.0	5.09
	15.0	14.0	51.1	5.39	51.1	5.17	51.1	5.09	51.3	5.01	48.9	4.91	47.3	4.88	44.9	4.83	42.6	4.79
	20.0	19.0	53.1	5.30	52.7	5.09	52.7	4.89	51.3	4.81	48.9	4.78	47.3	4.74	44.9	4.66	42.6	4.60
	25.0	23.0	57.1	5.27	54.7	5.01	53.7	4.74	51.3	4.66	48.9	4.61	47.3	4.61	44.9	4.53	42.6	4.45
	30.0	28.0	59.7	5.29	56.6	4.96	53.7	4.66	51.3	4.58	48.9	4.53	47.3	4.48	44.9	4.40	42.6	4.32
	35.0	32.0	59.7	5.24	56.6	4.91	53.7	4.61	51.3	4.45	48.9	4.40	47.3	4.40	44.9	4.32	42.6	4.23
	40.0	36.0	59.7	5.19	56.6	4.88	53.7	4.58	51.3	4.40	48.9	4.35	47.3	4.32	44.9	4.23	42.6	4.13
	45.0	41.0	59.7	5.16	56.6	4.83	53.7	4.53	51.3	4.35	48.9	4.33	47.3	4.23	44.9	4.18	42.6	4.13
	47.0	43.0	59.7	5.11	56.6	4.79	53.7	4.48	51.3	4.13	48.9	4.32	47.3	3.89	44.9	3.57	42.6	3.29
	50.0	46.0	59.7	4.94	56.6	4.61	53.7	4.32	51.3	4.00	48.9	3.89	47.3	3.76	44.9	3.44	42.6	3.18
	55.0	51.0	59.7	4.71	56.6	4.45	53.7	4.18	51.3	3.89	48.9	3.76	47.3	3.62	44.9	3.36	42.6	3.13
60.0	56.0	59.7	4.64	56.6	4.32	53.7	4.00	51.3	3.76	48.9	3.62	47.3	3.49	44.9	3.23	42.6	3.00	

Capacity rated using ISO 5151—Test Rating Standard for Non-Ducted Heat Pumps.
 Heating mode stable operation is ensured when the outdoor ambient wet-bulb temperature is between -4°F and 60°F.
 Power Input (PI) in kW and includes compressor(s) and outdoor fan motor(s).
 Rated with an equivalent piping length of 24.6 ft. and no change in elevation between the indoor and outdoor unit.
 MBh = Net Capacity
 R410A, 60 Hz

Due to differences in test method and procedures, capacity data values provided in these tables may differ from certified performance information published by AHRI or other standardized testing agencies. AHRI testing protocol sets the volume of air flowing over the coil at 444 CFM/ton and limits the number of indoor units connected to the system being tested. LG conducts capacity tests using airflow rates and limits the number of indoor units per system as stated in Table 4 (a and b) on pages 17–18, Table 5 on page 19, and Table 14 on page 56.



Table 17c: ARUN053GS2 Heat Pump—Nominal Heating Capacity

Combination Ratio (%)	Outdoor Air Temp (°F)		Indoor Air Temperature (°F) DB															
			59		61		64		67		70		73		76		80	
	DB	WB	MBh	PI	MBh	PI	MBh	PI	MBh	PI	MBh	PI	MBh	PI	MBh	PI	MBh	PI
70	-4	-4.4	38.0	5.58	38.0	5.58	37.6	5.63	37.6	5.70	37.6	5.63	37.6	5.58	36.3	5.68	33.7	5.53
	0	-0.4	39.3	5.67	39.3	5.63	39.3	5.70	38.9	5.75	38.9	5.75	38.9	5.63	36.7	5.76	34.1	5.57
	5.0	4.5	44.0	5.67	44.0	5.55	43.6	5.78	42.3	5.70	41.9	5.70	40.1	5.63	38.4	5.32	36.9	5.04
	10.0	9.0	47.0	5.48	47.7	5.14	45.7	5.14	44.9	5.55	42.7	5.55	41.4	5.45	39.3	5.01	37.3	4.60
	15.0	14.0	50.4	5.32	49.1	5.07	47.0	5.07	44.9	5.22	42.7	5.19	41.4	4.99	39.3	4.60	37.3	4.23
	20.0	19.0	52.3	5.25	49.6	5.02	47.0	5.02	44.9	5.06	42.7	4.88	41.4	4.68	39.3	4.32	37.3	3.99
	25.0	23.0	52.3	5.22	49.6	4.99	47.0	4.88	44.9	4.58	42.7	4.43	41.4	4.28	39.3	3.94	37.3	3.62
	30.0	28.0	52.3	5.17	49.6	4.91	47.0	4.61	44.9	4.28	42.7	4.13	41.4	3.97	39.3	3.67	37.3	3.39
	35.0	32.0	52.1	4.88	49.6	4.61	47.0	4.35	44.9	4.05	42.7	4.02	41.4	3.76	39.3	3.49	37.3	3.24
	40.0	36.0	52.3	4.79	49.6	4.46	47.0	4.17	44.9	3.90	42.7	3.87	41.4	3.61	39.3	3.34	37.3	3.10
	45.0	41.0	52.3	4.56	49.6	4.28	47.0	4.02	44.9	3.87	42.7	3.79	41.4	3.49	39.3	3.23	37.3	2.98
	47.0	43.0	52.3	4.41	49.6	4.13	47.0	3.87	44.9	3.64	42.7	3.76	41.4	3.38	39.3	3.15	37.3	2.95
	50.0	46.0	52.3	4.30	49.6	4.02	47.0	3.76	44.9	3.52	42.7	3.38	41.4	3.26	39.3	3.05	37.3	2.83
	55.0	51.0	52.3	4.10	49.6	3.87	47.0	3.64	44.9	3.41	42.7	3.26	41.4	3.15	39.3	2.93	37.3	2.72
60.0	56.0	52.3	3.99	49.6	3.76	47.0	3.52	44.9	3.29	42.7	3.20	41.4	3.08	39.3	2.85	37.3	2.64	
60	-4	-4.4	37.7	5.07	37.7	5.11	37.3	5.14	38.0	5.17	36.6	5.20	35.6	5.75	33.7	5.29	32.0	4.86
	0	-0.4	39.1	5.55	39.1	5.58	38.9	5.62	38.4	5.20	36.6	5.24	35.6	5.55	33.7	5.09	32.0	4.68
	5.0	4.5	43.9	5.62	42.4	5.90	40.3	5.65	38.4	5.24	36.6	5.04	35.6	4.84	33.7	4.46	32.0	4.12
	10.0	9.0	44.7	5.45	42.4	5.68	40.3	5.30	38.4	4.92	36.6	4.74	35.6	4.56	33.7	4.22	32.0	3.89
	15.0	14.0	44.7	5.30	42.4	5.20	40.3	4.86	38.4	4.53	36.6	4.36	35.6	4.20	33.7	3.89	32.0	3.57
	20.0	19.0	44.7	5.22	42.4	4.88	40.3	4.56	38.4	4.25	36.6	4.10	35.6	3.95	33.7	3.66	32.0	3.38
	25.0	23.0	44.7	4.74	42.4	4.43	40.3	4.15	38.4	3.89	36.6	3.74	35.6	3.61	33.7	3.34	32.0	3.11
	30.0	28.0	44.7	4.41	42.4	4.15	40.3	3.89	38.4	3.64	36.6	3.51	35.6	3.38	33.7	3.13	32.0	2.90
	35.0	32.0	44.7	4.13	42.4	3.89	40.3	3.67	38.4	3.41	36.6	3.38	35.6	3.20	33.7	2.96	32.0	2.77
	40.0	36.0	44.7	4.00	42.4	3.77	40.3	3.54	38.4	3.33	36.6	3.29	35.6	3.10	33.7	2.87	32.0	2.67
	45.0	41.0	44.7	3.87	42.4	3.64	40.3	3.41	38.4	3.26	36.6	3.23	35.6	2.96	33.7	2.78	32.0	2.60
	47.0	43.0	44.7	3.76	42.4	3.51	40.3	3.29	38.4	3.06	36.6	3.20	35.6	2.87	33.7	2.68	32.0	2.50
	50.0	46.0	44.7	3.59	42.4	3.38	40.3	3.20	38.4	3.00	36.6	2.90	35.6	2.82	33.7	2.62	32.0	2.44
	55.0	51.0	44.7	3.49	42.4	3.29	40.3	3.10	38.4	2.90	36.6	2.82	35.6	2.72	33.7	2.52	32.0	2.34
60.0	56.0	44.7	3.39	42.4	3.20	40.3	3.00	38.4	2.82	36.6	2.72	35.6	2.62	33.7	2.45	32.0	2.31	
50	-4	-4.4	37.3	5.01	35.4	5.01	33.6	4.97	32.0	4.97	30.6	4.79	29.6	4.61	28.0	4.25	26.6	3.92
	0	-0.4	37.3	5.27	35.4	5.53	33.6	5.17	32.0	4.81	30.6	4.63	29.6	4.45	28.0	4.10	26.6	3.79
	5.0	4.5	37.3	5.17	35.4	4.84	33.6	4.53	32.0	4.22	30.6	4.07	29.6	3.92	28.0	3.62	26.6	3.34
	10.0	9.0	37.3	4.88	35.4	4.56	33.6	4.27	32.0	3.99	30.6	3.84	29.6	3.71	28.0	3.43	26.6	3.16
	15.0	14.0	37.3	4.48	35.4	4.20	33.6	3.94	32.0	3.67	30.6	3.54	29.6	3.41	28.0	3.16	26.6	2.93
	20.0	19.0	37.3	3.85	35.4	3.94	33.6	3.71	32.0	3.46	30.6	3.34	29.6	3.23	28.0	3.00	26.6	2.78
	25.0	23.0	37.3	3.85	35.4	3.61	33.6	3.38	32.0	3.16	30.6	3.05	29.6	2.95	28.0	2.73	26.6	2.54
	30.0	28.0	37.3	3.56	35.4	3.38	33.6	3.18	32.0	2.98	30.6	2.87	29.6	2.78	28.0	2.59	26.6	2.39
	35.0	32.0	37.3	3.38	35.4	3.18	33.6	3.00	32.0	2.82	30.6	2.77	29.6	2.64	28.0	2.45	26.6	2.27
	40.0	36.0	37.3	3.28	35.4	3.08	33.6	2.90	32.0	2.72	30.6	2.68	29.6	2.55	28.0	2.37	26.6	2.19
	45.0	41.0	37.3	3.16	35.4	2.98	33.6	2.78	32.0	2.65	30.6	2.65	29.6	2.47	28.0	2.32	26.6	2.17
	47.0	43.0	37.3	3.03	35.4	2.87	33.6	2.72	32.0	2.55	30.6	2.64	29.6	2.39	28.0	2.24	26.6	2.09
	50.0	46.0	37.3	2.96	35.4	2.78	33.6	2.64	32.0	2.47	30.6	2.39	29.6	2.32	28.0	2.19	26.6	2.06
	55.0	51.0	37.3	2.88	35.4	2.72	33.6	2.55	32.0	2.39	30.6	2.34	29.6	2.26	28.0	2.11	26.6	1.96
60.0	56.0	37.3	2.80	35.4	2.64	33.6	2.47	32.0	2.34	30.6	2.26	29.6	2.19	28.0	2.06	26.6	1.93	

Capacity rated using ISO 5151—Test Rating Standard for Non-Ducted Heat Pumps.

Heating mode stable operation is ensured when the outdoor ambient wet-bulb temperature is between -4°F and 60°F. Power Input (PI) in kW and includes compressor(s) and outdoor fan motor(s).

Rated with an equivalent piping length of 24.6 ft. and no change in elevation between the indoor and outdoor unit.

MBh = Net Capacity

R410A, 60 Hz

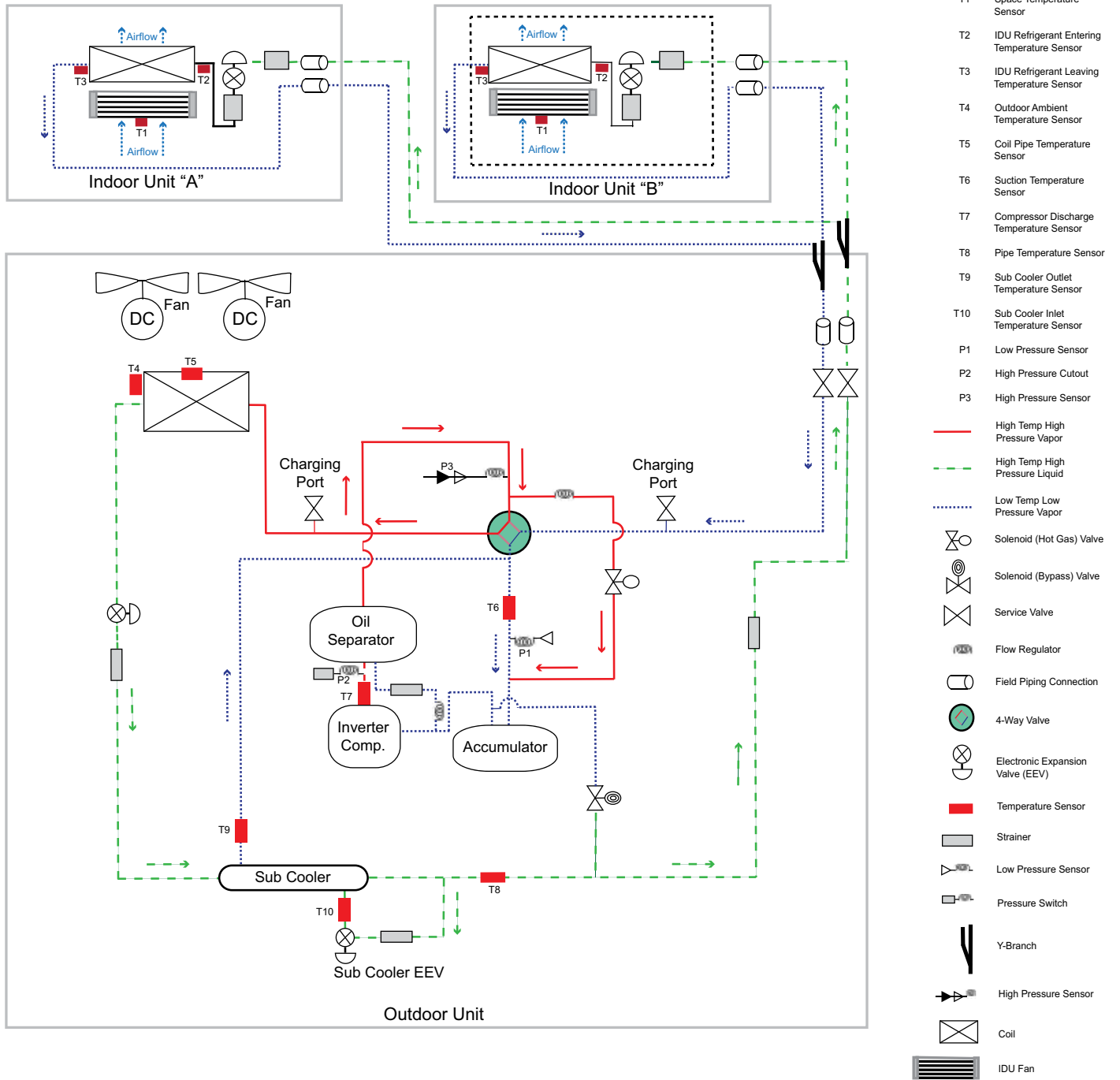
Due to differences in test method and procedures, capacity data values provided in these tables may differ from certified performance information published by AHRI or other standardized testing agencies. AHRI testing protocol sets the volume of air flowing over the coil at 444 CFM/ton and limits the number of indoor units connected to the system being tested. LG conducts capacity tests using airflow rates and limits the number of indoor units per system as stated in Table 4 (a and b) on pages 17–18, Table 5 on page 19, and Table 14 on page 56.

UNIT REFRIGERANT FLOW DIAGRAMS



Cooling Cycle Diagram

Figure 7: Cooling Cycle Flow Diagram—ARUN 036, 047, 053

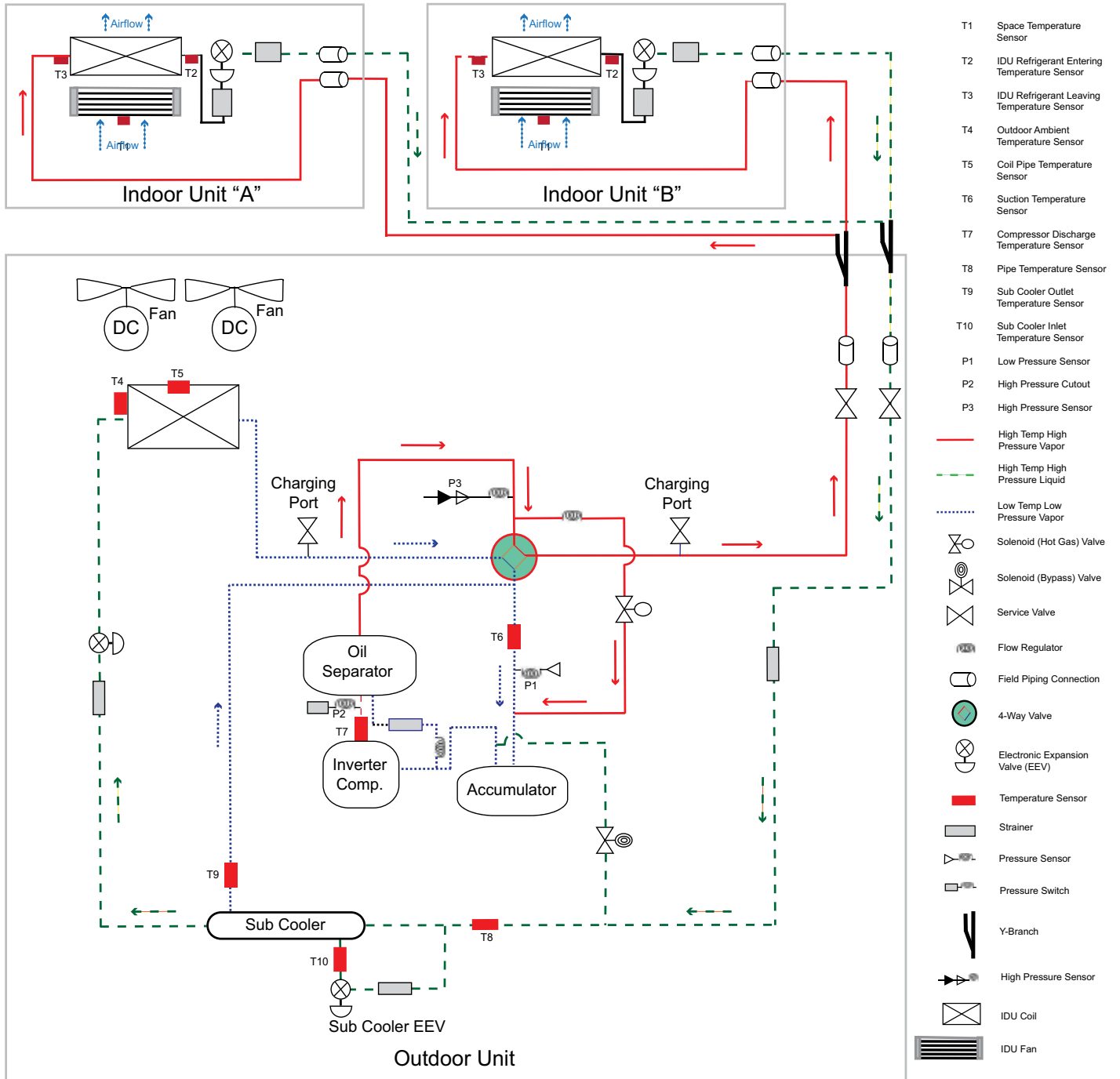


Performance Data

- T1 Space Temperature Sensor
- T2 IDU Refrigerant Entering Temperature Sensor
- T3 IDU Refrigerant Leaving Temperature Sensor
- T4 Outdoor Ambient Temperature Sensor
- T5 Coil Pipe Temperature Sensor
- T6 Suction Temperature Sensor
- T7 Compressor Discharge Temperature Sensor
- T8 Pipe Temperature Sensor
- T9 Sub Cooler Outlet Temperature Sensor
- T10 Sub Cooler Inlet Temperature Sensor
- P1 Low Pressure Sensor
- P2 High Pressure Cutout
- P3 High Pressure Sensor
- High Temp High Pressure Vapor
- - - High Temp High Pressure Liquid
- · · Low Temp Low Pressure Vapor
- ⊗ Solenoid (Hot Gas) Valve
- ⊗ Solenoid (Bypass) Valve
- ⊗ Service Valve
- ⊗ Flow Regulator
- ⊗ Field Piping Connection
- ⊗ 4-Way Valve
- ⊗ Electronic Expansion Valve (EEV)
- Temperature Sensor
- ▭ Strainer
- ▭ Low Pressure Sensor
- ▭ Pressure Switch
- ⊗ Y-Branch
- ▭ High Pressure Sensor
- ⊗ Coil
- ▭ IDU Fan

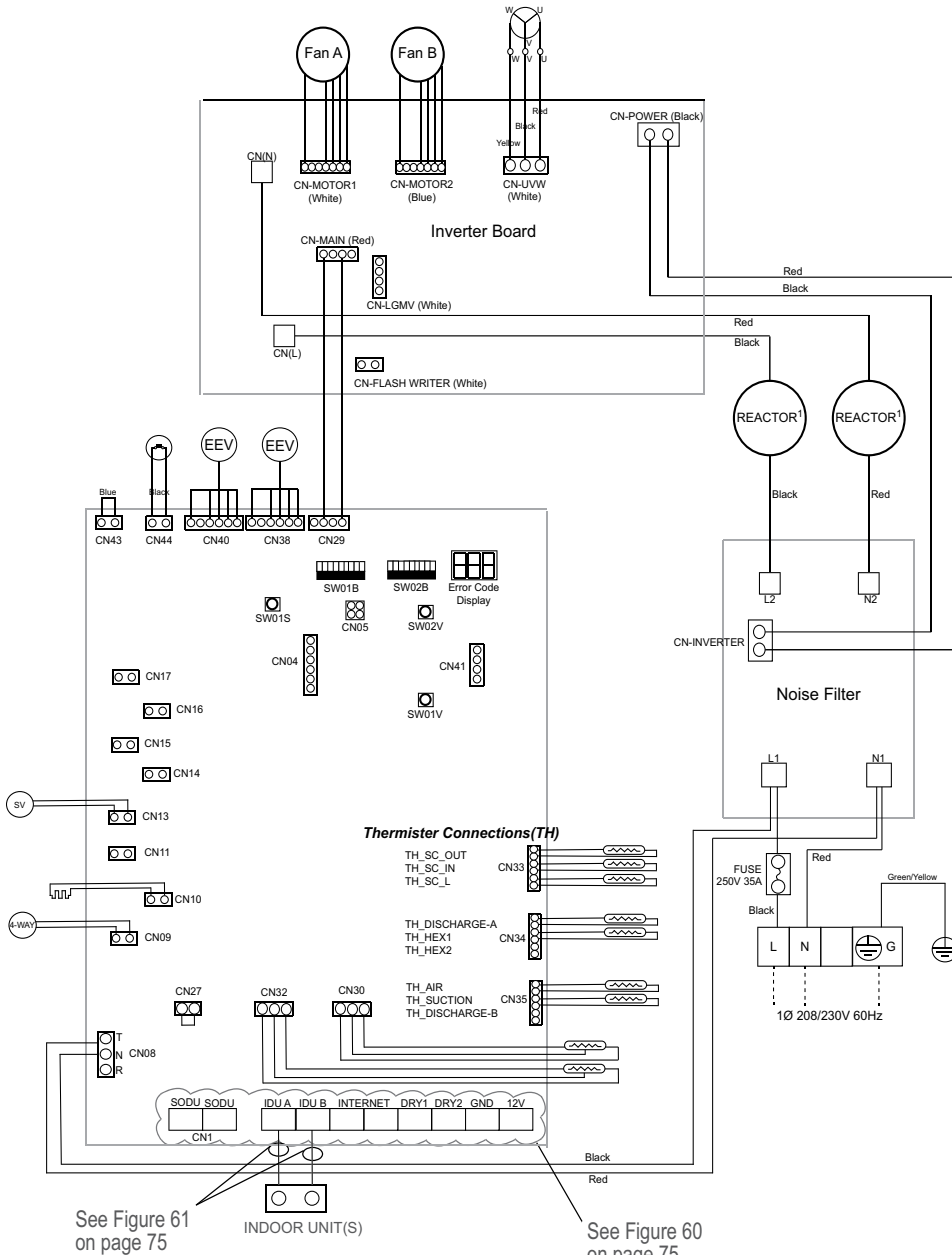


Figure 8: Heating Cycle Flow Diagram—ARUN 036, 047, 053



OUTDOOR WIRING DIAGRAM

Figure 9: Outdoor Unit Wiring Diagram



See Figure 61 on page 75

See Figure 60 on page 75

Color Legend	
Parentthesis ()	Socket Color
No Parenthesis	Wire Color

Symbol	Description
CN04	Connection for flashing system EPROM
CN05	Connection for LGMV Service Tool
CN08	Power to main board
CN09	4-way reversing valve
CN10	Inverter compressor crank case heater-A
CN11	Not Used
CN13	Hot gas bypass valve solenoid
CN14	Not Used
CN15	Not Used
CN16	Not Used
CN17	Not Used
CN27	Not Used
CN29	Communication with inverter board
CN30	High pressure sensor
CN32	Low pressure sensor
CN33	Subcooler outlet pipe thermistor (TH-SC_OUT)
CN33	Subcooler inlet pipe thermistor (SC_IN)
CN33	Subcooler liquid pipe thermistor (SC_L)
CN34	Compressor pipe thermistor (DISCHARGE-A)
CN34	Outdoor unit pipe thermistor 1 (HEX1)
CN34	Outdoor unit pipe thermistor 2 (HEX2)
CN35	Outdoor air thermistor (AIR)
CN35	Suction pipe thermistor (SUCTION)
CN35	High pressure sensor (DISCHARGE-B)
CN38	Electric expansion valve (Outdoor Coil)
CN40	Electric expansion valve (Subcooler)
CN41	Terminal for PI45 card connection
CN43	Not Used
CN44	Inverter compressor head pressure switch
CN-FLASH-WRITER	Connection for flashing inverter board EPROM
CN-INVERTER	AC power to inverter
CN-LGMV	Connection for LGMV service tool
CN-MAIN	Communication with main microprocessor
CN-MOTOR1	Communication/power connection for motor1
CN-MOTOR2	Communication/power connection for motor2
CN-POWER	AC power from noise filter
CN-UWV	Power to Inverter Compressor
SW01S	Control system reset button
SW02V	Auto Address button
SW01V	DATACONFIRM
	Line (+) power connection 208–230/60/1
	Neutral (-) power connection 208–230/60/1
	Ground

¹ Reactor—Power conditioner to minimize transient noise from the power source from entering the outdoor unit.

SYSTEM ENGINEERING

"Building Ventilation" on page 48

"Equipment Selection Procedure" on page 51

"Placement Considerations" on page 58

"Clearance Requirements" on page 59

"LATS Multi V Pipe System Design Tool" on page 61

"Pipe Design Parameters" on page 62

"Pipe Layout Procedure" on page 63

"Piping Design Guide" on page 66

"Jobsite Connections" on page 77

"Mini Refrigerant Charge" on page 79

ASHRAE 62.1 and local codes specify the minimum volume of outdoor air that must be provided to an occupied space. Outdoor air is required to minimize adverse health effects, and it provides acceptable indoor air quality for human occupants. The five methods that can be used with Multi V systems to meet the requirements are summarized here.

▲ Note:

Although we believe that building these ventilation methods have been portrayed accurately, none of the methods have been tested, verified, or evaluated by LG Electronics, USA, Inc. In all cases, the designer, installer, and contractor should understand if the suggested method is used, it is used at their own risk. LG Electronics USA, Inc. takes no responsibility and offers no warranty, expressed or implied, of merchantability or fitness of purpose if this method fails to perform as stated or intended.

For a complete copy of Standard 62.1-2010, refer to the American Standard of Heating and Air Conditioning Engineers (ASHRAE) website at www.ashrae.org.

For more information on how to properly size a ventilation air pretreatment system, refer to the article, "Selecting DOAS Equipment with Reserve Capacity" by John Murphy, published in the ASHRAE Journal, April 2010.

Method 1: Decoupled Dedicated Outdoor Air (DDOAS)

Provide a separate, dedicated outdoor-air system designed to filter, condition, and dehumidify ventilation air and deliver it directly to the conditioned space through a separate register or grille. This approach requires a separate independent ventilation duct system not associated with the Multi V system.

▲ Note:

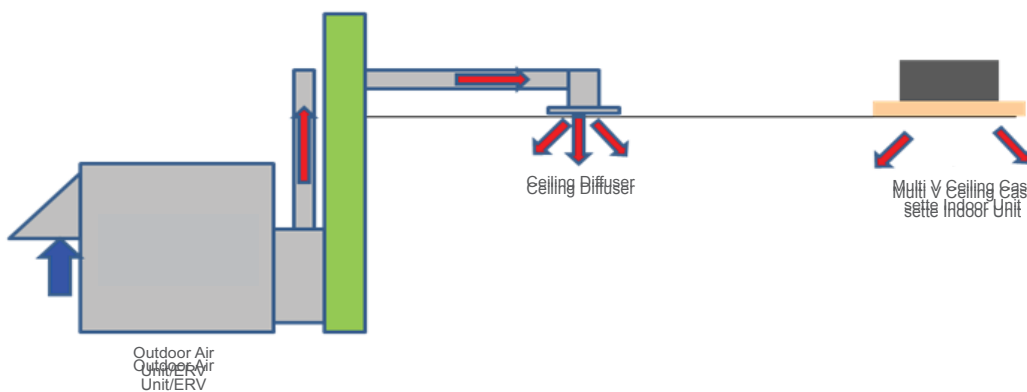
In all installations, LG recommends using the DDOAS method.

Advantages:

- Does not add additional heating or cooling loads to indoor units.
- May be used with a full lineup of the indoor units.
- If the outdoor air unit fails, the resulting untreated air will be readily noticed by the occupants.
- The outdoor air unit may supply neutral air to the occupied space even when the Multi V indoor unit fan changes speed or cycles on and off. DDOAS controls do not have to be interlocked with the Multi V system.
- In lieu of installing localized smaller outside air treatment equipment throughout the building, this method centralizes the ventilation outside air source making service and filter changes easier and less disruptive for the building occupants.
- Indoor unit operation and performance will not be affected by the condition of outdoor air.
- Third-party demand control ventilation controls are more readily accommodated.

Disadvantages:

- Ceiling space is required to accommodate ductwork between the centralized outdoor air unit and ceiling diffusers.



Method 2: Unconditioned Outdoor Air (Non-Ducted, Natural Ventilation)

Natural ventilation devices, such as operable windows or louvers may be used to ventilate the building when local code permits. The open area of a window or the free area of a louver must meet the minimum percentage of the net occupied floor area.

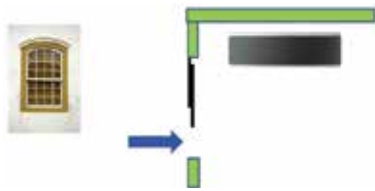
Note:
None

Advantages:

Occupants control the volume of the ventilation air manually.
Useful for historic buildings that have no ceiling space available for outdoor air ductwork.
May be used with the full lineup of Multi V indoor units.

Disadvantages:

In some locations, it may be difficult to control humidity levels when windows are open.
Thermal comfort levels may be substandard when windows are open.
Indoor units may have to be oversized to account for the added heating and cooling loads when windows are open.
Provides outdoor air to perimeter spaces only. Additional mechanical ventilation system may be required to satisfy requirements for interior spaces.
Outdoor air loads may be difficult to calculate since the quantity of outdoor air is not regulated.
May affect indoor unit proper operation when open.



Method 3: Unconditioned Outdoor Air Ducted to Indoor Units

Untreated outdoor air is channeled through a duct system that is piped to the return air duct on concealed indoor units or to the chassis of 1-way and 4-way cassettes.

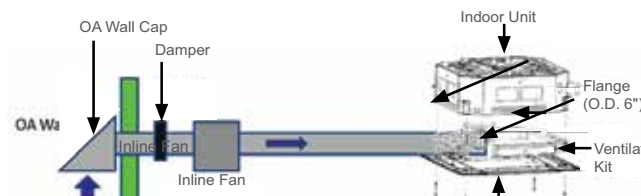
Note:
Outside air may flow backward through the return air-filter grille when the indoor unit fan speed slows or stops in response to changes in the space load. This may result in captured particulate on the filter media being blown back into the conditioned space.

Advantages:

May require less ductwork if indoor units are placed near outdoor walls or roof deck.
Controls must be interlocked to shut off the outdoor air supply fan when the space is unoccupied.
Third-party demand-control ventilation controls may be installed in order to regulate outdoor intake based on the CO₂ levels of the occupied space.

Disadvantages:

Fan(s) will be required to push outdoor air to the indoor unit. Indoor units are engineered for low sound levels and are not designed to overcome the added static pressure caused by the outdoor air source ductwork.
Ventilation air must be pre-filtered before mixing with the return air stream. LG indoor cassette models are configured to introduce the ventilation air downstream of the return air filter media.
Ducted, 1-way and 4-way cassette models are the only indoor units that accept the connection of an outdoor air duct to the unit case.
Mixed air conditions must be between a minimum of 59°F DB while operating in Heating mode and a maximum of 76°F WB while operating in Cooling mode. Depending on the ventilation air volume requirement, the location choices are limited where untreated outside air may be introduced to the building using this method.
Larger indoor units may be required to satisfy for additional outdoor air.
Motorized dampers may be required to prevent outdoor air flow through the indoor unit when the indoor unit is not operating.
An LG Dry Contact adapter may be necessary to interlock the motorized damper with the indoor unit.
While operating in Heating mode, the untreated outdoor air may delay the start of the indoor unit fan impacting building comfort.
In most cases, in lieu of using the factory mounted return-air thermistor on indoor units, a remote wall temperature sensor or zone controller will be needed for each indoor unit to provide an accurate reading of the conditioned area temperature.



Method 4: Unconditioned Outdoor Air (Non-Ducted, Fan Assisted Ventilation)

When approved by local codes, the fan assisted ventilation method uses exhaust fans to remove air from the building, and outdoor air is drawn into occupied spaces through a wall louver or gravity roof intake hood. Supply fans can also be used to push the outdoor air into the space and building positive pressure will vent the exhaust air through louvers or roof-mounted exhaust hoods. Outdoor air is neither cooled nor heated before entering the building.

⚠ Note:

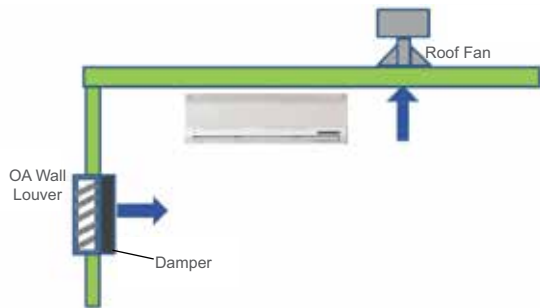
This may result in loss of building pressurization control, increasing infiltration loads with adverse effects.

Advantages:

Outdoor air may be manually controlled by the occupant or automatic controls may be installed to open/close outdoor air dampers or to turn on/off ventilation fans.
Useful for large open spaces like warehouses, garages, and workshops.
Outdoor air volume is a known quantity. Air loads may be easier to calculate since fans will regulate the amount of outdoor air.
May be used with a full lineup of Multi V indoor units.

Disadvantages:

In some locations of the country, it may be difficult to control humidity levels while outdoor air louvers/hoods are opened.
Thermal comfort levels may be substandard when louvers/hoods are opened.
Indoor units may have to be oversized to account for the added heating/cooling loads when louvers/hoods are open.
Hot, cold, and/or humid areas may be present if the outdoor air is not evenly distributed to the different spaces.



Method 5: Coupled Dedicated Outdoor Air (CDOAS)

A separate, dedicated outdoor air system delivers air directly to a Multi V indoor unit or to the return air duct system. After mixing with the return air stream, ventilation air passes through the indoor unit and into the conditioned space. The pretreatment system is capable of filtering, conditioning, and dehumidifying outdoor air to room neutral conditions.

⚠ Note:

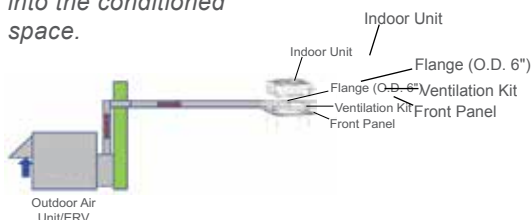
Outside air may flow backward through the return air-filter grille when the indoor unit fan speed is reduced or stops when the space load is satisfied. This may result in captured particulate on the filter media being blown back into the conditioned space.

Advantage:

Separate ceiling registers or grilles for introduction of the outside air to the conditioned space may be avoided.

Disadvantages:

Ducted, 1-way and 4-way cassette indoor units are the only models designed for direct connection of an outside air duct.
The building occupant may not notice the outdoor air pretreatment system has malfunctioned until the unconditioned outdoor air exceeds the indoor unit mixed air limits of 59°F DB for heating and 76°F WB for cooling.
If the coil entering air condition limitation is exceeded, the indoor unit may malfunction and prevent the indoor unit from operating.
If the outdoor air unit cooling or heating system fails, the malfunction may be masked by the indoor unit ramping up operating parameters to compensate for the failure.
Motorized dampers may be required to prevent outdoor air from entering the indoor unit while the indoor unit has cycled off.
An LG Dry Contact adapter is necessary to interlock the motorized damper with the indoor unit fan operation.
In lieu of using the factory mounted return-air thermistor, a remote wall temperature sensor or zone controller may be required to provide an accurate conditioned space temperature reading.



Always use LATS Multi V Software

To properly select and size Multi V system components, follow these guidelines:

- Zone the building
- Determine the ventilation method
- Select the indoor unit(s)
- Select the outdoor unit
- System sizing checks
 - Calculate the Corrected Capacity Ratio (CCR)
 - Determine the system Combination Ratio (CR)
 - Determine the Running (indoor) Unit Ratio (RUR)

The following procedure should not replace LG's LATS Multi V complimentary selection software, but should instead be used in conjunction with it. Contact your LG representative to obtain a copy of the software and the user's manual.

When using the LATS Multi V software, the default indoor design day conditions of 80.6°F DB / 67°F WB in cooling mode and 68°F DB / 56.7°F WB in heating mode may be adjusted to reflect the designer's preferred indoor room design temperature. These indoor room temperature values are the room thermostat setpoints and should not be confused with entering coil conditions.

▲ Note: Data provided in the LATS tree mode diagram or report file is not valid unless the Auto-Piping and System Check routines are run without errors. Errors will be reported immediately in pop-up dialog boxes or red lines surrounding indoor unit(s) and/or along pipe segments. If errors are indicated, modify the pipe system design and re-run LATS.

Zone the Building

Multi V Mini Heat Pump is a two-pipe heat pump system that can cool or heat, but not both simultaneously. Therefore, the designer should combine spaces with similar load profiles located near or adjacent to each other into "thermal zones." Calculate the peak cooling and heating loads for each thermal zone.

Determine the Ventilation Method

Decide how ventilation air will be introduced to each space. Add ventilation load(s) to the appropriate indoor unit(s) design cooling and heating loads only if the ventilation air treatment system does not provide room neutral air. Some models of Multi V indoor units are factory provided with or have accessories available that accommodate the direct connection of ventilation ductwork to the unit. However, there are product limitations and additional considerations that may need to be understood when using direct connection accessories. For more information, contact your LG applied equipment representative. Go to www.LG-VRF.com to find your representative and technical product information.

▲ Note: In all cases, LG recommends ducting pretreated, room neutral, ventilation air directly to the space. When pretreated, ventilation air is provided, remember to deduct the ventilation airload(s) from the total load before sizing the indoor unit(s). Local codes or other professional design guidelines, such as ASHRAE 62.1, will dictate the volume of ventilation air required.

It may be prudent to oversize the dedicated outdoor air system considering there will be a few days of the year when weather conditions exceed the design day conditions. This will minimize the possibility of ventilation air conditions causing the indoor unit's entering air temperature to fall outside the approved design temperature range. For more information on how to properly size a ventilation air pretreatment system, refer to the article, "Selecting DOAS Equipment with Reserve Capacity" by John Murphy, published in the ASHRAE Journal, April 2010.

Select the Indoor Unit(s)

Determine how many indoor units will be required. Refer to Table 1a to obtain the maximum number of indoor units allowed on a system. If an indoor unit will serve more than one space (i.e. ducted indoor unit or cassette equipped with up to two side branch ducts), combine the space and ventilation loads for all rooms served. If the quantity of indoor units exceeds the maximum allowed for the outdoor model selected, consider increasing the size of the outdoor unit or split the indoor units into two groups served by separate outdoor units.

Calculate the entering mixed air conditions for each indoor unit. The mixed-air temperature must be between 57°F and 76°F WB in Cooling mode and between 59°F and 80°F DB in Heating mode.

▲ Note: When the indoor unit entering air temperature is outside the cataloged operational limits, the system may continue to operate properly; however, operational abnormalities may occur. These include coil frosting, low or high suction temperature, low or high head pressure, low heating discharge temperature, or complete system shutdown.

To calculate the indoor unit entering mixed air temperature:

$$MAT = \frac{(RAT \times \%RA) + (OAT \times \%OA)}{100}$$

Where

- MAT = Mixed air temperature
- RAT = Return air temperature
- OAT = Outdoor air temperature
- %RA = Percentage of return air
- %OA = Percentage of outdoor air

EQUIPMENT SELECTION PROCEDURE

ARUN 036, 047, 053

▲ Note: Avoid over-sizing indoor units in an attempt to increase the room air recirculation rate. VRF systems are designed for minimum airflow over the coil to maximize latent capacity while cooling, maintain a comfortable, consistent discharge air temperature while heating, and minimize fan motor power consumption.

To properly size indoor unit(s), begin by referring to the output report provided by LG's LATS Multi V software and note the appropriate corrected cooling and heating capacity for each indoor unit for the cooling and heating design days.

In LATS, the corrected cooling capacity is different from the *nominal* cooling capacity because the corrected capacity includes changes in unit performance after considering refrigerant line pressure drop, the system's Combination Ratio (CR), and the effect design ambient operating conditions has on the indoor unit's cooling capability.

The building sensible cooling load is typically the critical load to satisfy. In coastal areas or humid applications, such as high occupancy spaces, both the latent and sensible cooling loads should be considered. In areas where the cooling and heating loads are similar or the heating load may exceed the total cooling load, the designer should verify the indoor unit selection satisfies both the heating and cooling requirements.

Check the indoor unit's cooling capacity. If the system is installed at a significant elevation above sea level, it may be appropriate to adjust the cooling capacity for changes in air density. Apply the appropriate altitude correction factor for the building's location to the outdoor and indoor units.

After applying the factor, verify the sensible (and total) corrected cooling capacity for each indoor unit is at least equal to the sum of the appropriate cooling design day space load(s) (plus ventilation load(s) if applicable) for the space(s) served by the indoor unit.

Next, check the indoor unit heating capacity. Begin by finding the corrected heating capacity detailed in the LATS report for each indoor unit. The corrected heating capacity is again different from the *nominal* heating capacity because the corrected capacity includes changes in unit performance after considering refrigerant line pressure drop and design ambient operating conditions on the indoor unit's heating capability. If the system is installed at a significant elevation above sea level, adjust the heating capacity for changes in air density. Apply the appropriate altitude correction factor for the building's location. Multiply the corrected heating capacity detailed in the LATS report for each indoor unit by the altitude correction factor selected.

Verify that the actual corrected heating capacity for each indoor unit is at least equal to the sum of the appropriate heating design day building load (plus the ventilation loads if applicable) for all spaces served by the indoor unit.

Select the Outdoor Unit

Table 18: Cataloged Ambient Air Operating Temperature Range

	Cooling Mode (°F DB)	Heating Mode (°F WB)
Multi V Mini	23 – 115	(-4) – 60

Note: Multi V Mini outdoor unit(s) may have to operate in weather conditions more extreme than a typical design day.

▲ Design days are the days of the year that either cooling or heating capacity is needed the most. In light of this, it may be prudent to size the outdoor unit considering the anticipated worst weather day conditions to ensure adequate capacity year round.

Begin the selection of the outdoor unit by selecting a size that meets the cooling capacity requirement. Then verify the selected unit meets the heating capacity requirement. Find the appropriate capacity table on pages 26–39 for the outdoor unit chosen. Locate the outdoor unit cooling and heating capacity values at the specified ambient design conditions.

When design outdoor ambient conditions are outside the cataloged air-cooled outdoor unit operating range, the net refrigeration effect (capacity) delivered to the indoor units cannot be guaranteed. Under these conditions, the possibility exists that the liquid injection valve or hot gas bypass valve in the outdoor unit may be open. When open, the outdoor unit will sacrifice capacity to maintain operational stability. As a result, the outdoor unit's net refrigeration effect available for use by the indoor units will be slightly reduced under certain extreme ambient air conditions.

Additionally, when the designer provides the LATS software with outdoor ambient air design conditions that are above or below the cataloged operational temperature range, the software will override the designers specified conditions and size the indoor and outdoor units and pipe system using the maximum or minimum cataloged ambient air operating temperature.

Also, it is important to know that the report generated by LATS (.xls format) will reflect the outdoor ambient air conditions the designer provides, but the indoor and outdoor unit(s) cooling and heating corrected capacities calculated and shown in the report will be based on the cataloged ambient air operating temperature limits of -4°F for the heating design day and 115°F for the cooling design day. On these projects, the designer must manually estimate the corrected cooling and heating capacity of the outdoor unit when specified ambient conditions are outside the cataloged range.

Note: To roughly estimate outdoor unit capacity at conditions outside the cataloged ambient air operating temperature range, manually extrapolate performance information provided in the appropriate outdoor unit engineering manual.

In lieu of designing for extreme weather conditions beyond the cataloged temperature range, consider limiting the maximum and/or minimum temperature of the air around the Multi V Mini outdoor

unit or consider a Multi V water-cooled alternative. These strategies are common on air-cooled projects in northern climates to eliminate “extreme” over-sizing of the outdoor unit(s).

Limit the surrounding outdoor unit air temperature by providing a ventilated equipment enclosure equipped with an auxiliary heat source. On heating days, the auxiliary heat source will provide the building engineer the ability to temper and control the minimum air temperature surrounding the outdoor unit(s). On extremely cold days, it may be more advantageous to operate the auxiliary heating equipment and limit the minimum ambient temperature in the enclosure in lieu of investing additional capital to install an extremely over-sized and de-rated Multi V outdoor unit. The enclosure also eliminates the potential operational problems caused by snow and ice. During the cooling season, the outdoor unit(s) will be protected from the adverse effects of direct sunlight.

After selecting an outdoor unit model and the outdoor unit's corrected cooling and heating capacity has been determined, there may be additional capacity correction factors to consider.

In Cooling mode, two correction factors may apply—one for the elevation difference between the outdoor unit and the indoor unit(s) and a second for the altitude above sea level. If the corrected cooling capacity was manually calculated, apply the appropriate elevation difference factor found in either Table 15 or Table 16 on page 56 (choice of table depends on the architecture of the system design). Multiply the manually calculated outdoor unit corrected cooling capacity by the elevation difference correction factor. If the corrected cooling capacity was derived from the LATS report, this elevation difference correction factor was already applied to the system design by LATS and no action will need to be taken.

If the system is installed at a significant elevation above sea level, the outdoor unit capacity will be affected by air density. Apply the appropriate altitude correction factor for the building's location to the outdoor unit capacity. The result is the actual corrected cooling capacity of the outdoor unit after all potential correction factors are considered.

After applying the appropriate cooling correction factors to the outdoor unit, verify the actual cooling capacity is at least equal to the total building load (considering building diversity, if applicable).

Next, determine the outdoor unit's actual corrected heating capacity. Two correction factors may apply—one for operating the outdoor unit with frost on the coil, and one for altitude above sea level. The impact of frost accumulation on the outdoor unit coil can be calculated by LATS or manually by the system designer. In certain weather conditions, frost may form and accumulate on the air-cooled outdoor unit coil at design day conditions. If design day conditions are below the dew-point of the surrounding air, frost is less likely to form on the coil and a frost accumulation correction factor may not need to be

considered.

When frost does accumulate on the outdoor unit coil, the outdoor unit capacity is affected and a defrost algorithm will start automatically. The timing between defrost periods is determined by the system's ability to achieve a target head pressure value. If frost accumulation is expected to occur at or near the winter design day conditions, LATS will automatically apply a frost accumulation factor if the check box labeled “Defrost Factor” in the outdoor unit selection dialog box is marked. The dialog box can be accessed by double-clicking on the outdoor unit image. If checked, the corrected outdoor unit capacity provided by the LATS report and displayed on the tree mode piping diagram will be automatically adjusted for outdoor unit coil frost accumulation.

To manually apply the frost accumulation factor, multiply the outdoor unit's manually calculated heating capacity or corrected heating capacity reported in LATS (verify the “Defrost Factor” check box was not marked) by the appropriate frost accumulation factor found in Table 21.

If the Multi V Mini system will be installed at a significant elevation above sea level, apply the frost accumulation factor (if necessary) to the corrected Heating capacity, and then multiply the resultant by the appropriate altitude correction factor.

After applying the appropriate heating correction factors, verify the outdoor unit actual corrected heating capacity is at least equal to the sum of the peak heating loads for all spaces and/or thermal zones served by the system.

System Sizing Checks

Calculate the Corrected Capacity Ratio (CCR)

The system's CCR is defined as the building total load divided by the outdoor unit corrected capacity after all applicable correction factors are applied. Calculate this ratio for both the cooling and heating design days.

$$CCR\%_{(Cg)} = \left(\frac{\text{Total Cooling Block Load}}{\text{Actual Corrected Outdoor Unit Cooling Capacity}} \right) \times 100 \leq 100\%$$

$$CCR\%_{(Htg)} = \left(\frac{\text{Heating Peak Load}}{\text{Actual Corrected Outdoor Unit Heating Capacity}} \right) \times 100 \leq 100\%$$

The outdoor unit selected should be large enough to offset the total cooling block load for all spaces served by the VRF system during the peak cooling load hour on the cooling design day (account for the ventilation air's cooling total load if ventilation air is not pretreated to room neutral conditions). Therefore, the corrected cooling capacity ratio ($CCR\%_{(clg)}$) should never exceed 100%. If the corrected cooling capacity ratio exceeds 100% (plus building diversity if considered), increase the size of the outdoor unit or change the system design by moving some of the building load and associated indoor unit(s) to another Multi V system.

The outdoor unit should also be large enough to offset the sum of the building's space heating loads without considering building diversity. In the heating season, it is typical that all spaces served by the system will peak simultaneously in the early morning, thus building diversity should never be considered. If the corrected heating capacity ratio ($CCR\%_{(htg)}$) exceeds 100%, increase the size of the outdoor unit, enclose the outdoor unit and provide control of the surrounding air conditions, or change the system design by moving some of the building load to another Multi V system.

Understanding the Combination Ratio (CR)

When first introduced to Variable Refrigerant Flow (VRF) technology, the designer often compares the system components with those of a traditional split-system. The VRF outdoor unit(s) is compared to a commercial split-system condensing units. Indoor units are compared with traditional fan coils and other forms of commercial and/or residential air moving products. The significant difference being a traditional heat pump system is comprised of a single air handler with a single condensing unit in a "one to one" relationship. A VRF system typically is comprised of a single frame unit (or multi-frame outdoor unit operating as a single unit) piped to numerous indoor units forming a "one to many" relationship between the outdoor and indoor units. With the introduction of the one to many relationship between VRF system ODU and IDU's, VRF manufacturer's introduced a new component relationship concept known as Combination Ratio (CR) to the industry.

Calculating the operating saturated suction temperature of a traditional split-system serves the same purpose as calculating the CR. Both calculations prevent mismatching system components.

Properly Matching Traditional Commercial Split-System Components

To properly match a traditional split-system (or split-system heat pump) condensing unit with an air handler equipped with a direct expansion coil, the designer would generate a refrigeration system cross plot diagram to reveal the system's balance point.

To generate a refrigeration system cross plot diagram, the manufacturer's computerized evaporator coil selection program is used to generate a graphical representation of the evaporator performance at indoor design conditions. To generate the graph, the physical

characteristics of the evaporator coil design are entered into the selection program and frozen. The designer will typically run the program a minimum of three times, each time making a selection with a different specified evaporator coil capacity. One selection condition will be done using the engineer's outdoor unit scheduled capacity, one at a higher and finally one at a lower capacity value.

The program will return the corresponding evaporator saturated suction temperature (SST) for each capacity specification. Each evaporator performance data point (MBh vs. SST) is subsequently plotted on the outdoor unit's capacity performance chart. A line is drawn between the plotted points. The drawn line depicts the evaporator coils capacity at various saturated suction temperatures. The condensing unit's capacity performance lines are provided by the outdoor unit manufacturer and are graphical representations of the unit's performance at various ambient air temperatures. The system's balance point and operating saturated suction temperature is where the evaporator capacity performance line crosses the appropriate condensing unit capacity performance line. The designer then identifies the system capacity and operating saturated suction temperatures at the balance point.

If the evaporator coil is too large or the condensing unit is too small, the system's operating saturated suction temperature will be too high to adequately cool the compressor. If the evaporator coil is too small or the condensing unit is too large, the system's operating saturated suction temperature will be too low and the possibility of slugging the compressor with liquid refrigerant exists. Therefore, if a split system is designed using mismatched components where there is an excessive difference in the heat transfer surface area of the evaporator coil relative to the condenser coil, the longevity of the system's compressor will be at risk.

Properly Matching VRF System Components

The same refrigeration theory and component matching verification applies to VRF systems. However, instead of the designer calculating the system's saturated suction operating temperature to verify a proper size match between the evaporator and condenser coils, VRF system designers must calculate and check the system's CR. If the system's CR is greater than 130%, the combined heat transfer surface area of all connected indoor units will be greater than the heat transfer surface of the outdoor unit(s), which under certain operating conditions, may raise the saturated suction operating temperature to an unacceptable level and result in a VRF system malfunction. If the system's CR is less than 50%, the combined heat transfer surface area of all connected indoor units is much less than the heat transfer surface of the outdoor unit(s). Under certain operating conditions, this may lower the saturated suction operating temperature to an unacceptable level, and result in a VRF system malfunction.

Compressor technology, system operational limitations, and the physical characteristics of R-410a refrigerant are very similar for

all VRF systems. Manufacturers of VRF equipment set acceptable system design CR parameters. LG limits the CR of a Multi V system to be between 50% and 130%. Even though a VRF manufacturer designs a system with what could be perceived as an excessive CR, the system's operating saturated suction temperature must be maintained in a similar operating temperature range as a VRF system designed with a CR between 50% and 130%. In general, compressor failures caused by excessive component mismatch are typically not revealed until the VRF system has operated for a substantial period of time. If a failure occurs, it will likely occur at peak load conditions.

How to Determine the System CR

The system's CR is determined by comparing the nominal capacity of all connected indoor units with the nominal capacity of the outdoor unit serving them. Locate nominal capacity information for indoor and outdoor units in the General Data tables of their respective engineering manuals.

For example,

If a VRF system has an outdoor unit with a nominal capacity of C and four indoor units having nominal capacity ratings of W, X, Y, and Z respectively, the CR would be determined as follows:

$$CR\% = \left(\frac{W + X + Y + Z}{C} \right) \times 100$$

▲ Note: Multi V systems will not start, operate, nor can they be commissioned if the CR is outside the allowable 50% to 130% range.

If the CR is over 100%, the designer is under-sizing the outdoor unit relative to the combined nominal capacity of the connected indoor units. In some applications, under-sizing of the outdoor unit is prudent as it reduces the initial equipment investment and will properly perform as long as the designer:

1. Knows the indoor unit(s) is oversized relative to the actual load(s) in the spaces served.
2. Knows the space loads will peak at different times of the day (i.e. building has "load diversity").

In some designs, over-sized indoor units may be unavoidable in cases where the smallest size indoor unit available from LG is larger than what is necessary to satisfy the space load. This scenario may occur when an indoor unit selection one size down from the selected unit is slightly short of fulfilling the design load requirements and the designer must choose the next largest size unit.

▲ Note: If the outdoor unit is properly sized to offset the building's total cooling block load and the system's CR is above 130%, indoor units are likely oversized. In applications where all indoor units are "right-sized" and there is no building diversity, the system's CR will likely be ≤100%.

If the CR is above 130%, review the indoor unit choices and down-size indoor units, or select a larger outdoor unit. Consider moving indoor units to another Multi V, Flex-Multi, or single-split system if the

outdoor unit size cannot be increased.

If the CR falls below 50%, select a smaller outdoor unit or consider adding more or larger indoor unit(s) to the system. This situation is common on multi-phase projects where the design calls for the majority of indoor units to be added to the system at a later date. To raise the CR above the minimum 50% requirement:

1. Consider adding additional indoor units on the first phase.
2. Design two smaller systems in lieu of a single larger system. Connect all "first phase" indoor units to the outdoor unit being installed on the first phase and delay the installation of the additional outdoor unit until a later date.

To avoid the potential of designing a system that may operate with an excessively high (or low) saturated suction temperature leading to premature compressor failure, do the following:

1. Design conservatively.
2. Verify the system's CR is between 50% and 130%.

EQUIPMENT SELECTION PROCEDURE



ARUN 036, 047, 053

Table 19: Outdoor Unit Cooling Capacity Correction Factor - Indoor Units above Outdoor Unit

Elevation Differences (ft)	Equivalent Pipe Length in Feet (ELF)*											
	25	33	66	98	131	164	197	230	263	295	328	≥ 361
0	1.00	0.99	0.97	0.95	0.93	0.91	0.88	0.87	0.85	0.83	0.83	0.82
25	1.00	0.99	0.97	0.95	0.93	0.91	0.88	0.87	0.85	0.83	0.83	0.82
33		0.99	0.97	0.95	0.93	0.91	0.88	0.86	0.85	0.83	0.82	0.82
66			0.96	0.95	0.93	0.9	0.88	0.86	0.85	0.83	0.82	0.82
98				0.94	0.92	0.9	0.88	0.86	0.84	0.83	0.82	0.82
131					0.92	0.9	0.88	0.86	0.84	0.83	0.82	0.82
164						0.9	0.88	0.86	0.84	0.83	0.82	0.82

* ELF = Equivalent Pipe Length in Feet—Sum of the actual pipe length plus allocations for pressure drop through elbows, valves, and other fittings in equivalent length.

Table 20: Outdoor Unit Cooling Correction Factor - Outdoor Unit above Indoor Units

Elevation Differences (ft)	Equivalent Pipe Length in Feet (ELF)*											
	25	33	66	98	131	164	197	230	263	295	328	≥ 361
0	1.00	0.99	0.97	0.95	0.93	0.91	0.9	0.87	0.88	0.84	0.86	0.84
25	1.00	0.99	0.97	0.95	0.93	0.91	0.9	0.87	0.88	0.84	0.86	0.84
33		0.99	0.98	0.95	0.93	0.91	0.9	0.88	0.88	0.84	0.86	0.84
66			0.98	0.95	0.93	0.91	0.9	0.88	0.88	0.84	0.86	0.84
98				0.96	0.93	0.91	0.9	0.88	0.89	0.84	0.86	0.84
131					0.93	0.91	0.9	0.88	0.89	0.84	0.86	0.84

* ELF = Equivalent Pipe Length in Feet—Sum of the actual pipe length plus allocations for pressure drop through elbows, valves, and other fittings in equivalent length.

Table 21: Outdoor Unit Frost Accumulation Factor (Heating)

Entering DB (°F)	19.4	23.0	26.6	32.0	37.4	41.0	44.6
De-rate Factor	0.98	0.95	0.93	0.86	0.93	0.96	1.0

At 85% outdoor air relative humidity.

The frost accumulation factor does not account for effects of snow accumulation restricting airflow through the outdoor unit coil.

General Mounting

Securely attach the outdoor unit to a condenser pad, base rails, or other approved mounting platform that has been securely anchored to the ground or building structure. Refer to Figures 10 through 13, and follow the applicable local code for clearance, mounting, anchor, and vibration attenuation requirements set fourth by the structural engineer.

Figure 10: Outdoor Unit—Mounting and Service Clearances (Plan View)¹

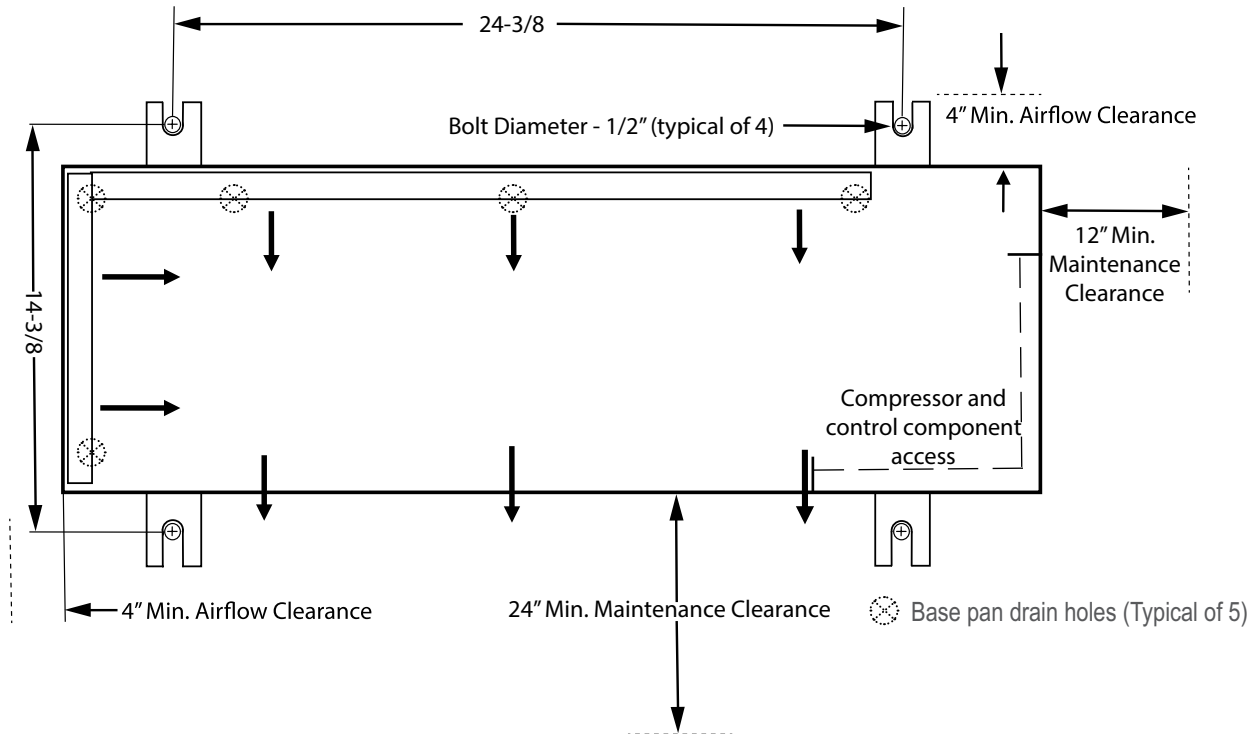


Figure 11: Outdoor Unit—Mounting and Service Clearances (Elevation View)

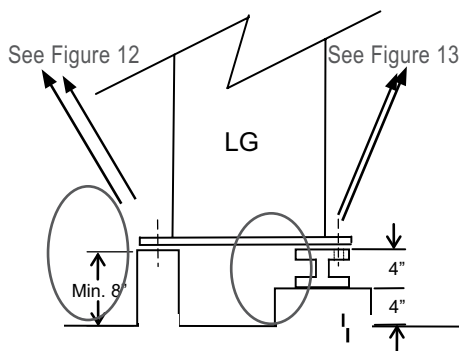


Figure 12: Mounting Method #1²

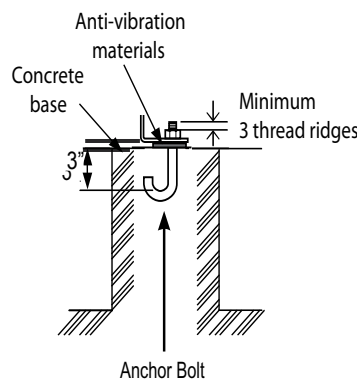
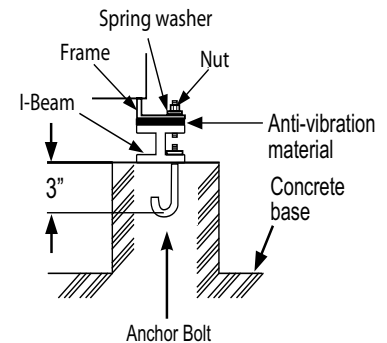


Figure 13: Mounting Method #2²



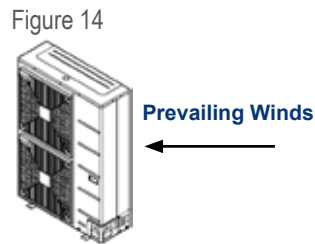
▲ Note:

1. Minimum airflow clearance specifications are based on a single unit installation without obstructions. Refer to "Clearance Requirements" on page 59 for specific airflow clearance requirements when obstructions are present.
2. All referenced materials are to be field-supplied.
3. Images are not to scale. All dimensions ±0.25 inches.

The Multi V Mini outdoor unit is designed to operate properly in a wide range of environmental conditions, but correct placement of the outdoor unit is essential for maximizing unit performance. Consider the following factors.

Wind Protection

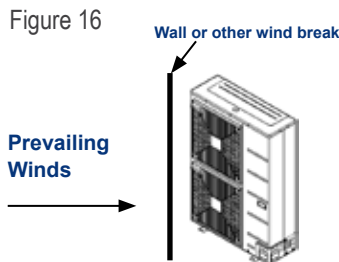
If the outdoor unit is located on a roof, position it with the compressor end (no coil surface) in the direction of the prevailing wind as shown in Figure 14. In cooler climates, it may be beneficial to position the unit in direct sunlight to assist with defrost operations.



If the outdoor unit is not located on a roof, it would be best to place it on the leeward side of the building or in a location where the unit will not be exposed to constant wind as shown in Figure 15.



If placement exposes the unit to constant wind activity, construct a wind break in front of the unit as shown in Figure 16. Follow the placement guidelines set forth in "Clearance Requirements" on page 59.



Mounting Platform

The underlying structure or foundation must be designed to support the weight of the unit. Unit weight is listed on the "Cut-sheet" on page 82. Avoid placing the unit in a low lying area where water may accumulate.

Tie-Downs and Wind Restraints

The strength of the Multi V Mini chassis is adequate to be used with field-provided wind restraint tie-downs. The overall tie-down configuration must be approved by a local professional engineer. Always refer to local code when designing a wind restraint system.

Dealing with Snow and Ice

In climates that experience snow buildup, place the unit on a raised platform to ensure proper outdoor unit coil airflow. The raised support platform must be high enough to allow the unit to remain above the anticipated snow accumulation level (consider snow drifts). Design the mounting base to prevent snow accumulation on the platform in front or back of the unit case. If necessary, use inlet and discharge duct or a snow hood to prevent snow or ice from accumulating on the coil, fan blades, and fan guards. Best practice prevents snow from accumulating on top of the unit as well. When the system is commissioned, adjust the DIP switch for "snow throw" operation if a snow hood is not used. In all cases, the outdoor unit supply and/or discharge duct work or hood must be designed to have a combined air pressure drop rating that does not exceed 0.16 in-wg.

Note: Snow throw mode does not prevent ice from forming on the fan blade or discharge grille.

Ambient Air Conditions

Do not place the unit in a corrosive environment. Avoid exposing the outdoor unit to steam, combustible gases, chimneys, steam relief ports, other air conditioning units, kitchen vents, plumbing vents, discharge from boiler stacks, and other sources of extreme temperature, gases, or substances that may degrade performance or cause damage to the unit. When installing multiple outdoor units, avoid placing the units where discharge air from the front of one outdoor unit is blown into the back side of an adjacent unit.

Electromagnetic Waves

Do not expose the unit to electromagnetic waves from equipment including, but not limited to generators, MRI equipment, or other equipment that emits electromagnetic waves.

The control system may be affected by electromagnetic waves, which may result in abnormal system operation. Also, the inverter components in these units may generate electromagnetic noise. Therefore, ensure that there is enough distance between the outdoor unit and any computer, stereo, and other electronic equipment. In weak electrical wave areas, ensure there is at least 9.8 feet between indoor unit remote controllers and other electrical devices. Insert power cables and other wires into separate conduits.

Handling Outdoor Unit Condensate

While operating in the Heating mode, the surface temperature of the outdoor coil may drop below the dew-point of the surrounding air. Moisture may condense on the coil fins and subsequently drain onto the surface of the surrounding area from the bottom of the unit case. If the designer chooses to control the flow of condensate from the outdoor unit, install a field-provided drain pan under the unit and pipe the condensate to a nearby drain. Mount the unit in the pan on rails or isolation pads. If the unit will be operating near or below freezing with a condensate drain pan installed, consider installing heat tape in the bottom of the outdoor unit drain pan and along the condensate drain line.

Clearance Requirements—General

Proper airflow through the outdoor unit coil is critical for proper unit operation. Figures 17 through 32 illustrate minimum space requirements for various installation scenarios for the ARUN036GS2 (3.0 ton), ARUN047GS2 (4.0 ton), and ARUN053GS2 (4.4 ton). Use the hot isle/cold isle (back to back or face to face) approach when placing multiple units in close proximity to each other. Outdoor unit fans draw air from the back of the unit and discharges out the front.

Legend:

LR = Rear wall height
LF = Front wall height
H = Unit height

Note:

Installation clearances must comply with local building codes.

All figures not to scale.

Never place multiple units facing back to front or front to back as shown below.

High and low system pressure problems may occur.



Figure 19: Single Unit—high rear wall with or without high side walls

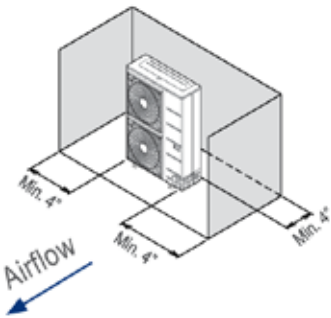


Figure 22: Single Unit—high rear and side walls with building overhang

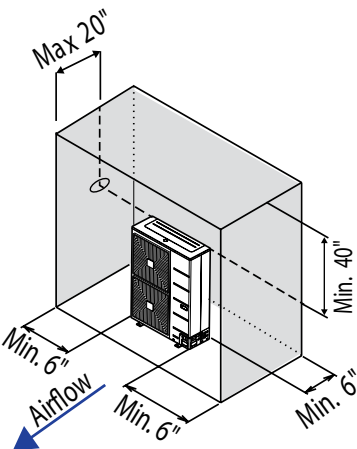


Figure 17: Single Unit—high front wall with building overhang and no side walls

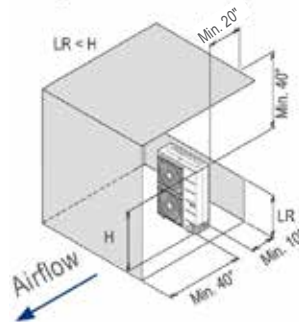


Figure 20: Single Unit—high rear and front walls with no side walls

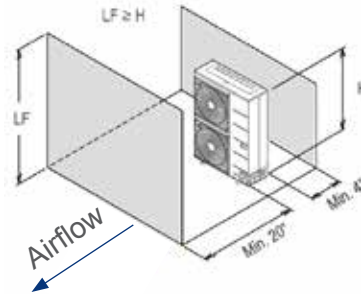


Figure 23: Single Unit—high front and rear walls with building overhang and no side walls

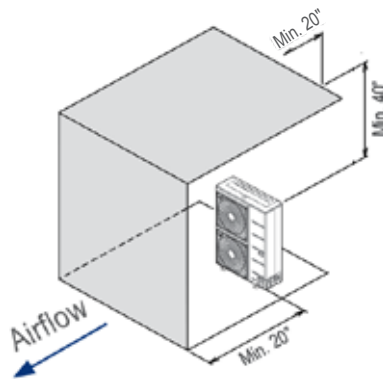


Figure 18: Single Unit—high rear wall and low front wall with no side walls

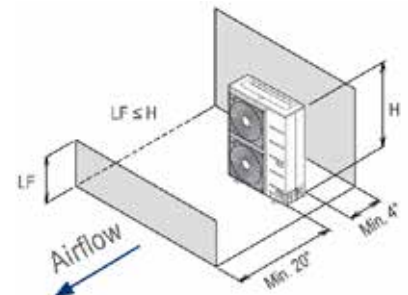


Figure 21: Side by Side—high rear and side walls

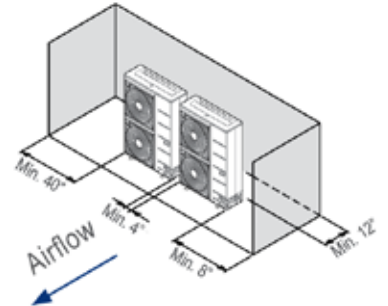
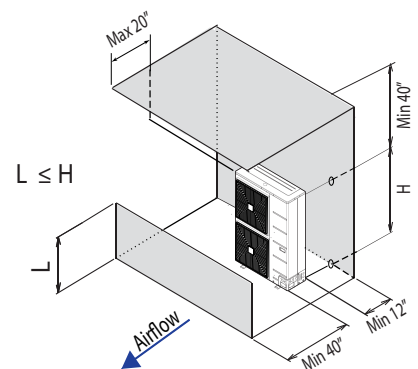


Figure 24: Single Unit—high rear wall and low front wall with building overhang and no side walls



CLEARANCE REQUIREMENTS

Outdoor Unit Minimum Clearance

Legend:

LR = Rear wall height
LF = Front wall height
H = Unit height

Note:
Installation clearances must comply with local building codes.
All figures not to scale.

Figure 25: Side by Side—high rear and side walls with building overhang

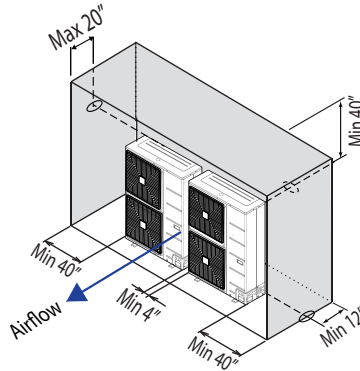


Figure 26: Side by Side—high rear and front walls with building overhang

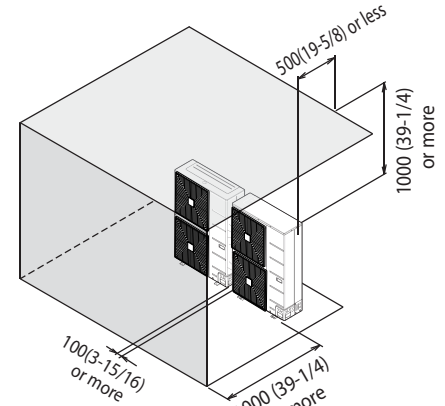


Figure 27: Single Row Units—high rear wall and low front wall with no side walls or overhang

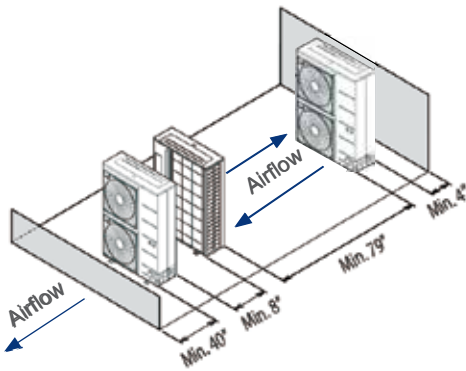


Figure 28: Side by Side—high front wall with building overhang and no side or rear walls

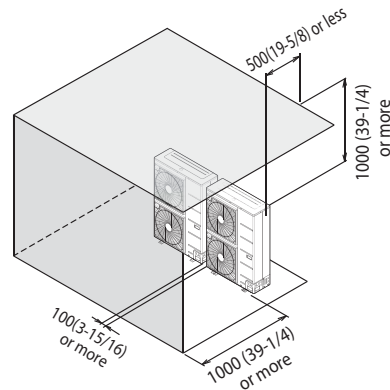


Figure 29: Side by Side—high rear wall and low front wall with no side walls

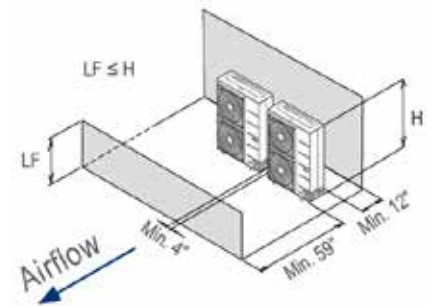


Figure 30: Double Row Units—low rear and front walls with no side walls or overhang

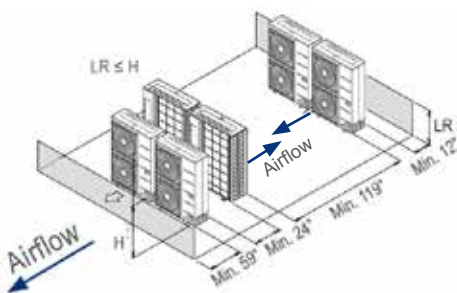


Figure 31: Side by Side—high front and rear walls with no side walls

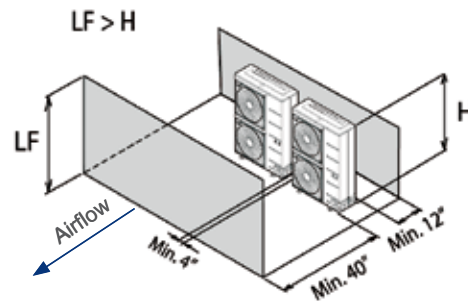
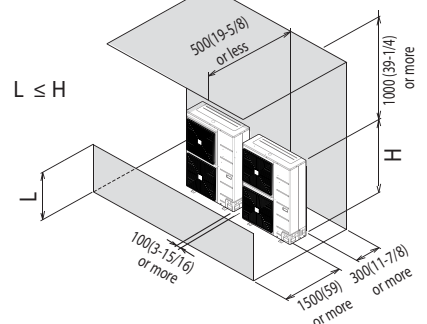


Figure 32: Side by Side—high rear wall and low front wall with building overhang and no side walls



When installed in predominately cold climates:

- Install a field-provided snow hood to keep out snow and rain.
- Ensure the outdoor unit is installed to avoid direct contact with snow. If the unit is installed in a snowy area, attach a field-provided snow hood over the coil inlet and/or outlet. If snow accumulated and freezes on the fan inlet and/or outlet, the system may malfunction.
- Install the outdoor unit at least 19-3/4 inches higher than the average annual snowfall.
- The height of the mounting base must be more than 2 times the average annual snowfall.
- The width of the mounting base must not exceed the width of the unit. Snow may accumulate if the width of the frame is wider than that of the unit.
- Make sure the fan inlet and the fan discharge of the outdoor unit are facing away from the seasonal wind.

LATS Multi V

The proper design and installation of the refrigerant piping system is a critical element of the Multi V system. Multi V Mini requires two pipes between system components—a liquid line and a vapor line. A properly designed refrigerant piping system ensures that refrigerant is delivered to the evaporator coil's electronic expansion valve (EEV) in a pure liquid state free of gas bubbles. A proper design also ensures a sufficient refrigerant gas flow rate in the vapor line that eliminates the possibility of refrigeration oil from collecting in the vapor line. The piping system can be engineered manually using the procedure outlined in the "Pipe Layout Procedure" on page 63; however, the preferred method is to design the system using LG's LATS Multi V software.

LATS Multi V is a Windows-based application that assists the engineer in the design of the refrigeration distribution pipe system, verifies the design complies with most pipe design limitations, applies selected capacity correction factors, and calculates the system refrigerant charge.

Adjusting LATS Multi V Output for Altitude

When a system is installed at elevations significantly above sea level, the designer must also consider the impact air density has on the capacity of the indoor and outdoor units. An altitude correction factor must be manually applied to the indoor and outdoor unit data provided in the LATS report or tree diagram. Refer to the "Select the Outdoor Unit" procedure on page 52 for more information.

Design Choices

LATS Multi V is flexible, offering the HVAC system engineer a choice of two design methods:

- Using the CAD mode, the refrigerant pipe design and layout work is performed concurrently. Simply import a copy of a plan view drawing (.dwg format) for each floor of the structure into LATS Multi V. Select and place system components on the floor plan drawing(s), and draft interconnecting pipe between system components and riser pipe segments between floors. Once the layout is complete, use the export feature to create a file (.dxf format) that can subsequently be imported into the building design drawings.
- Using the TREE mode, the engineer can quickly create a one-line schematic drawing of the Multi V system and create an export file of the tree diagram in .dxf format. Integration of the engineered pipe system layout into the building drawings is done at a later date by the drafts person using standard drafting software tools.

Note: On multiple story buildings, all floor drawings must have the same reference point relative to each other.

In either case, LATS Multi V generates a report file (.xls format) containing project design parameters, cooling and heating design day system component performance, and capacity data. The report calculates the system CR, calculates the system refrigerant charge, and provides detailed bill of material information including a list of Multi V outdoor units, indoor units, control devices, accessories, and refrigerant pipe sizes segregated by building, by system, by pipe size, and by pipe segments.

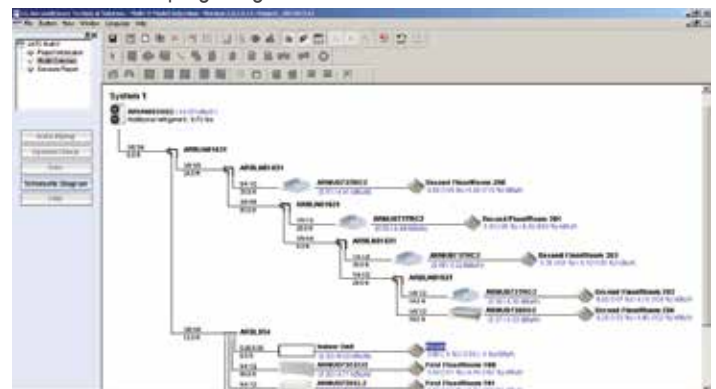
CAD mode

- Imports the building's architectural CAD drawing (.dwg format)
- Imports building loads from an external file (.xls format)
- Lays out refrigerant piping directly onto an overlay of the building drawing
- Assigns room loads to indoor units
- Automatically calculates pipe segment lengths based on drawing layout
- Creates an export image file for import to the building drawing set (.dxf format)
- Generates a system engineering report (.xls format)

Tree mode

- Imports building loads from an external file (.xls format)
- Selects system component using an easy drag and drop process
- Automatically analyzes and checks the design complies with most piping design limitations
- Assigns room loads to indoor units
- Sizes refrigerant piping
- Generates a system engineering report (.xls format)
- Generates a picture of the piping tree diagram (.dxf format)

Figure 33: Screenshot of LATS Pipe System Design Tool Displaying a Tree Mode Piping Diagram



Liquid Line Pipe Design Parameters

Device Connection Limitations

- Minimum number of connected indoor units per system = 1.
- Minimum number of operating indoor units per system = 1.
- Maximum number of indoor units on a system is:

ARUN036 = 6
 ARUN047 = 8
 ARUN053 = 9

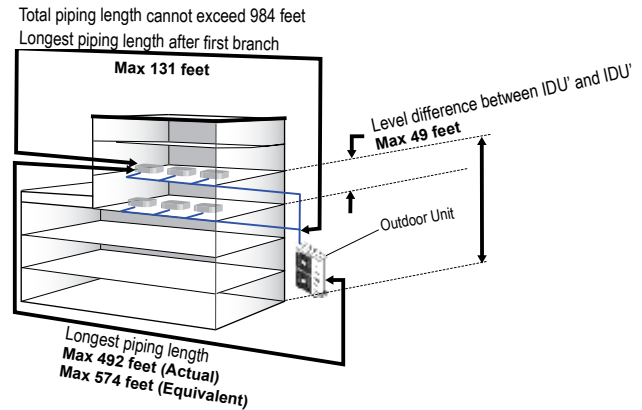
Table 22: Multi V Mini Liquid-Line Pipe-Design Parameters

Pipe Length*	Total System	984 ELF
	Longest distance from ODU to IDU	492 feet (Actual) 574 feet (Equivalent)
	Distance between fittings and IDUs	≥ 20" ELF
	Minimum distance between IDU to any Y-Branch	≤ 131 ELF
	Maximum distance between first Y-Branch to farthest IDU	131 feet
	Minimum distance from IDU to Y-Branch	3 feet
Elevation	If ODU is above IDU	164 feet
	If ODU is below IDU	131 feet
	Between any two IDUs	49 feet

IDU = Indoor Unit
 ODU = Outdoor Unit
 All elevation limitations are measured in actual feet
 ELF = Equivalent length of pipe in feet
 * Limitations refer to the liquid line length (not the sum of the liquid and vapor)

Figure 34: Multi V Mini Pipe Configuration Limitations

a. If the outdoor unit is mounted below the indoor unit(s)



b. If the outdoor unit is mounted above the indoor unit(s)

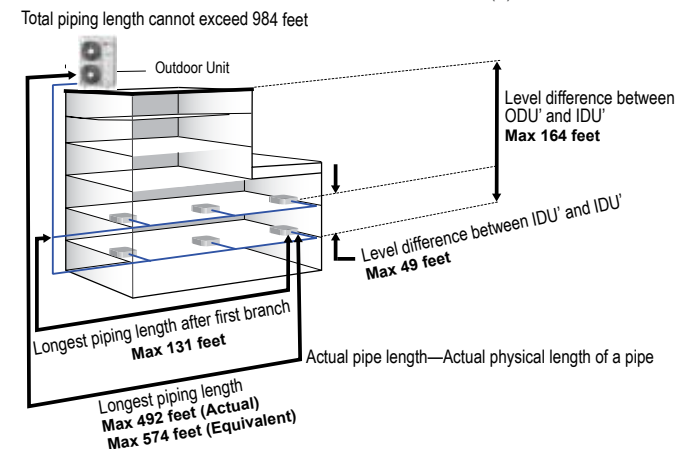


Table 23: Field-Supplied Refrigerant Fittings—Liquid Line Equivalent Pipe Length

Copper Tubing Size (OD)	Equivalent Pipe Length*					
	3/8	1/2	5/8	3/4	7/8	1-1/8
Standard 90° Elbow	0.6	0.9	1.3	1.6	1.9	2.5
Long Radius 90° Elbow	0.4	0.6	0.8	1.0	1.3	1.7
Street 90° Elbow	1.0	1.6	2.1	2.6	3.1	4.2
Standard 45° Elbow	0.3	0.5	0.7	0.8	1.0	1.3
Street 45° Elbow	0.5	0.8	1.1	1.4	1.6	2.2
Y-Branch	1.6	1.6	1.6	1.6	1.6	1.6
Header	3.3	3.3	3.3	3.3	3.3	3.3
Ball Valve	The equivalent length of a FULL port ball valve is the physical length of the valve. Ignore the valves and treat as straight pipe. A full port ball has the same bore diameter as the connected pipe.					

* Equivalent pipe length in feet—The sum of the actual pipe length plus allocations for pressure drop through elbows and valves located in the liquid line.

Values are calculated based on formula and factors from www.sporlanonline.com.

LG supplied Y-Branch and Header fittings must be used. Field-built Y-Branch and Header fittings are not permitted.

Creating a Balanced Piping System

Balancing dampers, ball valves, orifices, circuit setters, or other flow control devices cannot be used to modify or balance the flow of refrigerant in a VRF piping system. Therefore, variable refrigerant flow systems must be designed to be "self balanced." Pipe sizing considerations include pipe length, pipe segment pressure drop relative to other pipe segments in the system, type and quantity of elbows, bends present, fitting installation orientation, and indoor unit elevation differences. Balanced liquid refrigerant distribution is solely dependent on the designer choosing the correct pipe size for each segment.

It is imperative the designer avoids creating excessive pressure drop. In the liquid line, the pipe system must be designed in a manner that avoids the creation of unwanted vapor. When liquid refrigerant is subjected to excessive pressure drop, the refrigerant will change state and "flash" to vapor. If vapor bubbles form in a stream of liquid refrigerant before reaching the electronic expansion valve (EEV), loss of system temperature control and EEV valve damage may occur.

Handling Field Piping Changes

Any field changes, such as rerouting, shortening or lengthening a pipe segment, adding or eliminating elbows and/or fittings, re-sizing, adding, or eliminating indoor units, changing the mounting height, or moving the location of a device or fitting during installation should be done with caution and always verified in LATS Multi V before piping supplies are purchased or installed. Doing so may have a positive effect on job profit, eliminate rework, and may avoid unexpected necessary pipe changes before commissioning.

Layout Procedure

When this procedure is complete, the liquid line working drawing should contain the information for each pipe segment and others entities depicted in Figure 35 on page 65.

1. Choose the location of the indoor units and draw them on the building drawing.
2. Choose the location of all Y-Branch and Header fittings and add them to the drawings. Verify that all fittings are positioned per the guideline limitations set forth in "Y-Branch Kits" on page 66 and "Header Kits" on page 67.
3. Plan the route for interconnecting piping. Draw a one-line depiction of the pipe route chosen on the building drawings.
4. Calculate the actual length of each pipe segment and note it on the drawing next to each segment.
5. Using the data obtained while selecting the system components from the "Equipment Selection Procedure" on page 51, list the *nominal* cooling capacity next to each indoor unit on the drawing.
6. Starting at the runout segment servicing the indoor unit located farthest from the outdoor unit, note the connected *nominal* capacity of the indoor unit served by the pipe segment. Record these values next to each segment on the drawing.
7. At the branch or pipe segment upstream of the farthest Y-Branch or Header fitting from the outdoor unit, note the downstream connected *nominal* capacity of all indoor units served by the pipe segment. Record these values next to the segment on the drawing. Repeat the same procedure for each branch and main pipe segment working your way up the liquid line back toward the outdoor unit for each leg of the piping system. When completed, all segments will be noted with the *nominal* capacity of the downstream indoor units served by each segment.
8. Use Table 24 to select the correct pipe size for both the liquid and vapor lines. Note the chosen line sizes next to each segment.
9. Size Y-Branch and Header fittings. Refer to Cut-Sheets for "Y-Branch Kits" on page 4 and "Header Kits" on page 5 to determine the part number of each LG Y-Branch and/or Header based on the connected downstream *nominal* capacity served. Record the part number next to each fitting.
10. Calculate the equivalent pipe length in feet of the branch and main pipe segments. Y-Branch and Header equivalent lengths should be included with the upstream segment only. Use equivalent pipe length data provided with purchased fittings. If unavailable, use the data provided in Table 24. Y-Branch and Header equivalent lengths are found in the Cut-Sheets on pages 4 and 85. Equivalent length values will be used to calculate the system refrigerant charge.
11. Verify the actual and/or equivalent pipe length complies with the limitations listed in Table 23. If the limitations are exceeded, either reroute the pipe or change the location of selected Y-Branch fittings, Header fittings, and/or indoor unit locations so the design conforms with all limitations.
12. Verify the manually sized pipe design is acceptable using LATS Multi V. Using the LATS tree mode modeling option, enter the actual pipe length of each pipe segment. Account for the additional pressure drop created by elbows by double-clicking on the segment length text in LATS Multi V. In the dialog box, enter the elbow count.
13. After entering all necessary information into LATS, click on the "Auto Pipe" button on the left followed by the "System Check" button located under the "Auto Pipe" button. If no dialog boxes pop up indicating an error and none of the entities on the tree mode diagram have a red box around or along them, the pipe design is acceptable and the layout work is complete. If errors were indicated, modify the pipe design as needed. For assistance, contact the applied product representative in your area.

Table 24: Pipe Segment Sizing— All pipe dimensions are inches OD

Model	Main Pipe Segment ¹				Branch and Run-Out Segments ^{2,3}					
	< 295 feet equivalent		≥ 295 feet equivalent		≤ 19.1 MBh downstream capacity		> 19.1 MBh < 54.6 MBh downstream capacity		≥ 54.6 MBh ≤ 68.9 MBh downstream capacity	
	Liquid	Vapor	Liquid	Vapor	Liquid	Vapor	Liquid	Vapor	Liquid	Vapor
ARUN036GS2	3/8	5/8	3/8	3/4	1/4	1/2	3/8	5/8	–	–
ARUN047GS2	3/8	5/8	3/8	3/4	1/4	1/2	3/8	5/8	–	–
ARUN053GS2	3/8	3/4	3/8	3/4	3/8	3/4	3/8	3/4	3/8	3/4

1. Select the equivalent length of the longest pipe run between the outdoor unit and the furthest indoor unit.
2. Capacity (MBh) = The sum of the *nominal* capacity of all connected indoor units served by the pipe segment.
3. If the sum of the *nominal* cooling capacity of all connected indoor units served by a branch or run-out segment is greater than the capacity of the outdoor unit, size the pipe segment based on the outdoor unit *nominal* capacity.

Figure 35: Typical System Drawing Showing a Liquid Line Layout

Main—The pipe segment between the outdoor unit and the first Y-Branch or Header kit

Branch—A segment of pipe between two Y-Branched or a Y-Branch and a Header kit

Run-out—The segment of pipe connecting an indoor unit to a Y-Branch or Header kit

●—Full Port Ball Valve
(Install on both liquid and vapor lines)

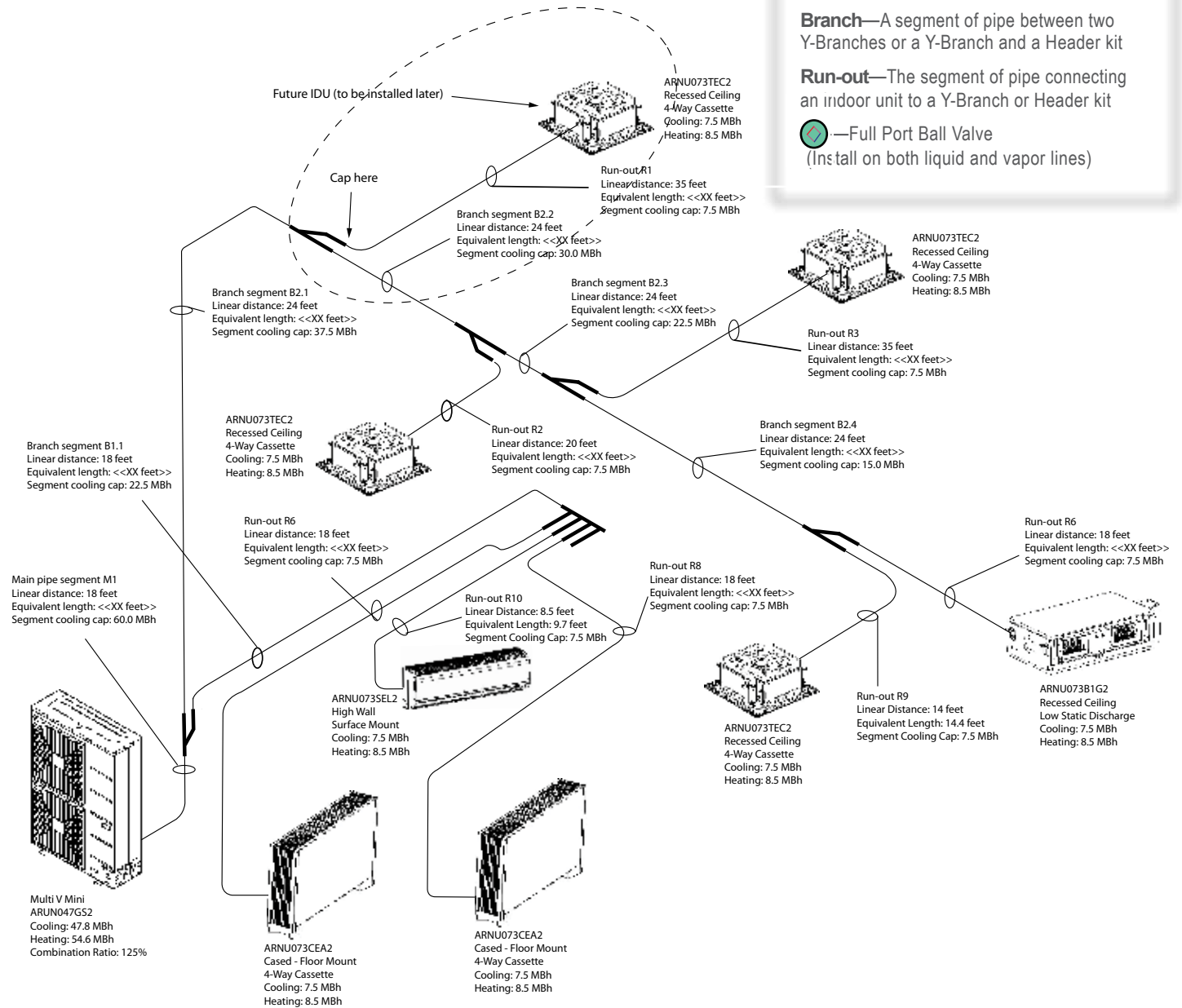


Table 25: Pipe Segment Sizes

Segment Tag	M1	B1.1	B2.1	B2.2	B2.3	B2.4	R1	R2	R3	R4	R5	R6	R7	R8	R9	R10
Liquid Line Dia. OD (in)	3/8	3/8	3/8	3/8	3/8	1/4	1/4	1/4	1/4	1/4	1/4	1/4	1/4	1/4	1/4	1/4
Vapor Line Dia. OD (in)	3/4	5/8	5/8	5/8	5/8	1/2	1/2	1/2	1/2	1/2	1/2	1/2	1/2	1/2	1/2	1/2

All sizes are internal diameter in inches.

M = Main pipe segment, B = Branch pipe segment, R = Run-out pipe segment

General:

The Y-Branch and Header kits are used to join one pipe segment to two or more segments. See Cut-Sheets: "Y-Branch Kits" on page 80 and "Header Kits" on page 81 for sizes and dimensions.

LG Y-Branch kits consists of:

- Two Y-Branched (one liquid line, one vapor line)
- Reducer fittings as applicable
- Molded clam-shell type insulation covers

LG Header kits consists of:

- Two Headers (one liquid line, one vapor line)
- Reducer fittings as applicable
- Molded clam-shell type insulation covers

Y-Branch Kits

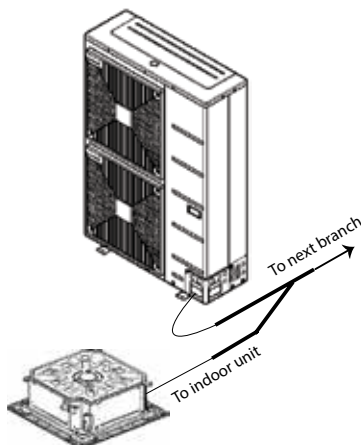
▲ Note: Only LG supplied Y-Branch and Header fittings can be used to join one pipe segment to two or more segments.

LG Y-Branch and Header kits are precision engineered devices designed to evenly divide the flow of refrigerant. Third-party or field fabricated Tee's, Y-fittings, Headers, or other branch fittings are not qualified for use with LG Multi V systems. The only field-provided fittings allowed in a Multi V piping system are 45° and 90° elbows and full-port ball valves.

There is no limitation on the number of Y-Branched that can be installed, but there is a limitation on the number of indoor units connected to a single outdoor unit. See Table 1a on page 14.

Avoid installing Y-Branched backwards as shown in Figure 36. Refrigerant flow cannot make U-turns through Y-Branched.

Figure 36: Connecting Y-Branch Kits



The pipe coming from the outdoor unit should always connect to the single port end of the Y-Branch as shown in Figure 37.

Y-Branched may be installed in a horizontal or vertical configuration. When installed in the horizontal configuration, position the fitting so the take-off leg shares the same horizontal plane as the straight-thru leg $\pm 10^\circ$ as shown in Figure 38c. When installed in a vertical configuration, position the fitting so the straight-thru leg is $\pm 3^\circ$ of plum. See Figure 38 (a and b).

The first Y-Branch kit must be located at least 3 feet from the outdoor unit. Provide a minimum of 20 inches between a branch fitting and any other fitting or indoor unit piped in series to avoid generating refrigerant flow noise into the system.

It is recommended that when a Y-Branch is located in a pipe chase or other concealed space, access doors should be provided for access and inspection.

See "Refrigerant Pipe System Insulation" on page 76 for pipe system insulation information.

Y-Branch Insulation

Each Y-Branch kit comes with two clam-shell type peel and stick insulation jackets molded to fit the Y-Branch fittings as shown in Figure 39—one for the liquid line, one for the vapor line.

1. Check the fit of the Y-Branch clam-shell insulation jacket after the Y-Branch is installed.
2. Verify there will be no exposed pipe between the end of the Y-Branch, jacket, and adjacent pipe insulation.
3. Mark the pipe where the insulation jacket ends.
4. Remove the jacket.

5. Install field-provided insulation on the 3 pipes first.
6. Peel the adhesive glue protector slip and install the clam-shell jacket over the fitting.

Figure 37: Y-Branch Connections

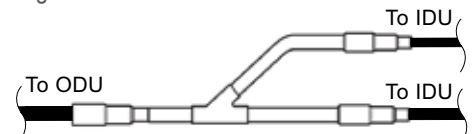


Figure 38: Y-Branch insulation alignment specification

a. Vertical Up Configuration



b. Vertical Down Configuration



c. Horizontal Configuration End View

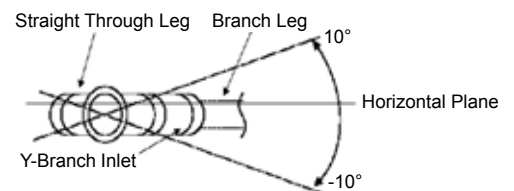
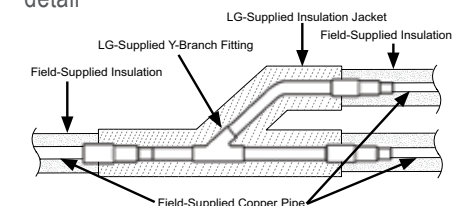


Figure 39: Y-Branch insulation and pipe detail



Header Kits

⚠ Note: Y-Branches can be installed upstream between the Header and the outdoor unit, but a Y-Branch cannot be installed between a Header and an indoor unit.

To avoid the potential of uneven refrigerant distribution through a Header fitting, minimize the difference in equivalent pipe length between the Header fitting port and each connected indoor unit.

Header kits are intended for use where multiple indoor units are in close proximity to each other or where it would be more economical to “home-run” the run-out pipe segments back to a centralized location. If connecting multiple indoor units that are far apart, Y-Branches may be more economical. See Tables 38 and 39 on page 4 for Header kit specifications and capacity.

Install Headers in a horizontal and level position with the distribution ports of the fitting in the same horizontal plane as the straight-thru branch as shown in Figure 41.

When connecting indoor units to a Header, it is best practice to connect the unit with the largest nominal capacity to the port closest to the outdoor unit. Then install the next largest indoor unit to the next port working down to the smallest indoor unit. Avoid skipping ports. See Figure 40.

All indoor units must be mounted at an elevation below the Header fitting. All indoor units connected to a single Header fitting should be located with an elevation difference between connected indoor units that does not exceed 49 feet. If indoor units are located at an elevation the same as or above the Header fitting, do not use a Header. Instead install a Y-Branch fitting between the outdoor unit and the Header fitting and connect the elevated indoor unit to the Y-Branch.

Figure 40: Header Kit

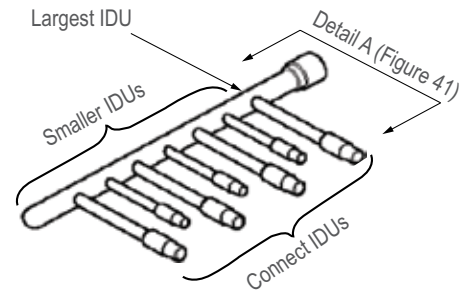
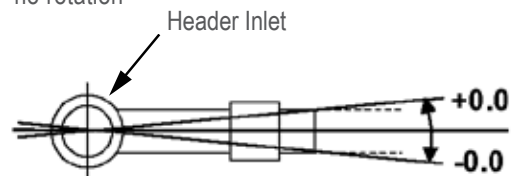


Figure 41: Header Kit—Must be installed level with no rotation

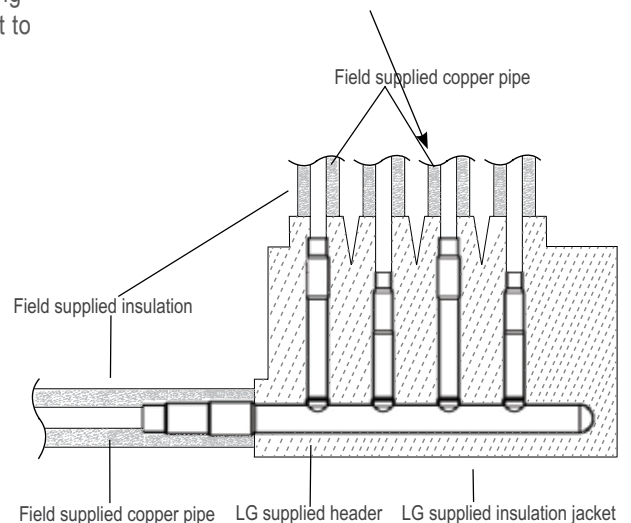


Detail A—Figure 40—Header Fitting Installation End View

Header Insulation

Each Header kit comes with two clam-shell type peel and stick insulation jackets molded to fit each Header fitting—one for the liquid line and one for the vapor line as shown in Figure 42. See "Refrigerant Pipe System Insulation" on page 76 for pipe system insulation information.

Figure 42: Header Insulation and Pipe Detail



Engineering for Future Indoor Units

Commissioning in Stages

Begin with the end in mind to avoid system downtime, unnecessary costs, and the replacement of installed pipe segments when adding subsequent indoor units and/or changing the location or size of existing units after the system is initially designed and commissioned. Complete the following at the same time the initially installed portion of the system is complete:

- Placement decisions for all future indoor units
- Piping plan for future piping
- Sizing of future pipe segments

In these applications, the future pipe design must be verified using LG's LATS Multi V software to confirm the pipe design complies with LG's design limitations after all future indoor unit additions and planned pipe system changes are made. Install isolation ball valves on the liquid and vapor lines near the Y-Branch or Header on each leg where the future run-out piping and unit will be connected. If possible, avoid installing the pipe segment between the ball valve and the location of the future indoor unit during the initial phase of the project. Cap the future pipe segment 3 to 6 inches from the ball valve discharge and open the valve before system evacuation and charging. Close the valve after charging the system. Doing so ensures that refrigeration oil will return to the compressor sump and not be trapped in future-use pipe segments. For example, refer to Figure 35 and review the drawing of the run-out segment tagged R1. It is very important to verify the system's CR is at least 50% initially and that it does not exceed 130% after all future indoor unit changes and/or additions are completed. See "How to Determine the System Combination Ratio (CR)" on page 55 for more information. Verify the anticipated RUR is within the limitations listed on page 55.

Using Elbows

Third-party elbows are allowed as long as they are designed for use with R410A refrigerant. The designer and installer should use a minimum number of fittings since they must consider the pressure drop each creates measured in equivalent length of pipe in feet. When using the LATS Multi V software or when performing manual calculations, the additional equivalent pipe length of all fittings must be accounted for in the respective segments. See Table 23 on page 62.

Field-Provided Isolation Valves

LG neither provides nor requires isolation ball valves on indoor units for proper system operation. If isolation is desired, full-port isolation ball valves with Schrader ports (positioned between valve and indoor unit) rated for use with R410A refrigerant should be used on the liquid and vapor lines. Position the valves so they are easily accessible for service. If necessary, install drywall access doors or removable ceiling panels. Position valves with 3 to 6 inches of pipe on either side. Position valves with adequate clearance for applying field insulation. If valves are not installed and a single indoor unit needs to be removed or repaired, the entire system must be shut down and evacuated. If isolation ball valves are installed, the unaffected indoor units may be operated after the control system is rebooted if the system CR (excluding the disconnected unit) remains between 50% and 130%. See "How to Determine the System Combination Ratio (CR)" on page 55.

Refrigerant Specialties

In-line refrigeration components, such as solenoid valves, filter-dryers, sight glasses, tee fittings, and after-market refrigerant pipe system accessories are prohibited and cannot be used with the Multi V Mini. Sight-glasses, solenoid valves, and tee fittings may cause gas bubbles to form in the liquid line. Over time, dryers may deteriorate and introduce debris into the system.

Oil Traps

Oil traps are not permitted. The Multi V system is engineered with redundant systems that ensure oil is properly returned to the compressor. The designer and installer should verify that the refrigerant piping system is free of oil traps. For instructions on routing a pipe segment around an obstacle, see "Handling Obstacles" on page 74.

Selecting Copper Tubing

Copper is the only approved refrigerant pipe material for use with LG Multi V commercial air conditioning products. Hard-drawn or annealed copper tubing is acceptable, and the designer chooses which one to use.

- Drawn temper ACR copper tubing is available in sizes 3/8 thru 1-1/8 inches (ASTM B 280, clean, dry, and capped).
- Annealed temper ACR copper tubing is available in sizes 1/4 thru 1-1/8 inches (ASTM B 280, clean, dry, and capped).

Choose the tube wall thickness to meet local codes, UL standards, and it must be approved for an operating pressure of 551 psig. If local codes do not specify wall thickness, LG suggests using tubing sizes as specified in Table 26. When bending soft copper tubing, use the largest radius bends wherever possible to reduce the equivalent length of installed pipe. Be sure no traps or sags are present when rolling out and installing soft copper tubing.

Table 26: ACR Copper Tubing Material

Type	Seamless Phosphorous Deoxidized
Class	UNS C12200 DHP
Straight Lengths	H58 Temper
Coils	O60 Temper

Table 27: ACR Copper Tubing Dimensions/Physical Characteristics

Nominal Pipe OD (in)	Actual OD (in)	Drawn Temper			Annealed Temper		
		Nominal Wall Thickness (in)	Weight (lb/ft)	Cubic ft. per Linear ft.	Nominal Wall Thickness (in)	Weight (lb/ft)	Cubic ft. per Linear ft.
1/4	0.250	-	-	-	0.030	0.081	.00020
3/8	0.375	0.030	0.126	.00054	0.032	0.134	.00053
1/2	0.500	0.035	0.198	.00101	0.032	0.182	.00103
5/8	0.625	0.040	0.285	.00162	0.035	0.251	.00168
3/4	0.750	0.042	0.362	.00242	0.042	0.362	.00242
7/8	0.875	0.045	0.455	.00336	0.045	0.455	.00336
1-1/8	1.125	0.050	0.655	.00573	0.050	0.655	.00573

All dimensions provided are in accordance with ASTM B280.
 Design pressure = 551 psig.
 Annealed (soft) and drawn temper tubing is suitable for use with flared and brazed fittings.
 Annealed tubing is available in 50 ft. coils.

The type of tubing selected for use in a particular application is determined by the internal fluid pressure of the R410A refrigerant at the highest operating condition.
 Source: The Copper Tube Handbook, 2010, Copper Development Association Inc., 260 Madison Avenue, New York, NY 10016.

Copper Expansion and Contraction

Under normal operating conditions, the vapor pipe temperature of a Multi V Mini system can vary as much as 280°F. With this large variance in pipe temperature combined with a potential straight run pipe of up to 492 feet and a segment length between fittings of up to 131 feet, the designer must consider pipe expansion and contraction to avoid potential pipe and fitting fatigue failures.

Refrigerant pipe along with the insulation jacket form a cohesive unit that expands and contracts together. During system operation, thermal heat transfer occurs between the pipe and the surrounding insulation.

If the pipe is mounted in free air space, no natural restriction to movement is present if mounting clamps are properly spaced and installed. When the refrigerant pipe is mounted underground in a utility duct stacked among other pipes, natural restriction to linear movement is present. In extreme cases, the restrictive force of surface friction between insulating jackets could become so great that natural expansion ceases and the pipe is “fixed” in place. In this situation, opposing force caused by the change in refrigerant fluid/vapor temperature can lead to pipe/fitting stress failure.

The refrigerant pipe support system must be engineered to allow free expansion to occur. When a segment of pipe is mounted between two fixed points, provisions must be provided to allow pipe expansion to naturally occur. The most common method is the inclusion of expansion Loop or U-bends. See Figure 43 on page 72. Each segment of pipe has a natural fixed point where no movement occurs. This fixed point is located at the center point of the segment assuming the entire pipe is insulated in a similar fashion. The natural fixed point of the pipe segment is typically where the expansion Loop or U-bend should be placed. Linear pipe expansion can be calculated using the following formula:

$$LE = C \times L \times (T_r - T_a) \times 12$$

Where

- LE = Anticipated linear tubing expansion (in.)
- C = Constant (For copper = 9.2×10^{-6} in./in.°F)
- L = Length of pipe (ft.)
- T_r = Refrigerant pipe temperature (°F)
- T_a = Ambient air temperature (°F)
- 12 = Inches to feet conversion (12 in/ft.)

Refer to Table 28 and 29 for anticipated expansion distances for copper pipe.

1. From Table 28, find the row corresponding with the actual length of the straight pipe segment.
2. Estimate the minimum and maximum temperature of the pipe.
3. In the column showing the minimum pipe temperature, look up the anticipated expansion distance. Do the same for the maximum pipe temperature.
4. Calculate the difference in the two expansion distance values. The resultant will be the anticipated change in pipe length.

For example,

A Multi V Mini heat pump system is installed and the design shows that there is a 260 feet straight segment of tubing between a Y-Branch and an indoor unit. In Heating mode, this pipe transports hot gas vapor to the indoor units at 120°F. In Cooling mode, the same tube is a suction line returning refrigerant vapor to the outdoor unit at 40°F. Look up the copper tubing expansion at each temperature and calculate the difference.

Vapor Line

Transporting Hot Vapor: 260 ft. pipe at 120°F = 3.64 in.
 Transporting Suction Vapor: 260 ft. pipe at 40°F = 1.04 in.
 Anticipated change in length: 3.64 in. – 1.04 in. = 2.60 in.

Liquid Line

The liquid pipe temperature will not vary significantly. Only the direction of flow will change.

Creating an Expansion Joint

When creating an expansion joint, the joint height should be a minimum of two times the joint width. Although different types of expansion arrangements are available, the data for correctly sizing an expansion loop is provided. Use soft copper with long radius bends on longer runs or long radius elbows for shorter pipe segments. Use the anticipated linear expansion (LE) distance calculated, and look up the Loop or U-bend minimum design dimensions. If you choose other types of expansion joints, design per ASTM B-88 standards.

Table 28: Linear Thermal Expansion of Copper Tubing in Inches

Pipe Length	Fluid Temperature °F																			
	35°	40°	45°	50°	55°	60°	65°	70°	75°	80°	85°	90°	95°	100°	105°	110°	115°	120°	125°	130°
10	0.04	0.04	0.05	0.06	0.06	0.07	0.08	0.08	0.09	0.09	0.10	0.10	0.11	0.11	0.11	0.12	0.13	0.14	0.15	0.15
20	0.08	0.08	0.10	0.12	0.13	0.14	0.15	0.16	0.17	0.18	0.19	0.20	0.21	0.22	0.22	0.23	0.26	0.28	0.29	0.30
30	0.12	0.12	0.15	0.18	0.20	0.21	0.23	0.24	0.26	0.27	0.29	0.30	0.32	0.33	0.32	0.35	0.39	0.42	0.44	0.45
40	0.16	0.16	0.20	0.24	0.26	0.28	0.30	0.32	0.34	0.36	0.38	0.40	0.42	0.44	0.43	0.46	0.52	0.56	0.58	0.60
50	0.20	0.20	0.25	0.30	0.33	0.35	0.38	0.40	0.43	0.45	0.48	0.50	0.53	0.55	0.54	0.58	0.65	0.70	0.73	0.75
60	0.24	0.24	0.30	0.36	0.39	0.42	0.45	0.48	0.51	0.54	0.57	0.60	0.63	0.66	0.65	0.69	0.78	0.84	0.87	0.90
70	0.28	0.28	0.35	0.42	0.46	0.49	0.53	0.56	0.60	0.63	0.67	0.70	0.74	0.77	0.76	0.81	0.91	0.98	1.02	1.05
80	0.32	0.32	0.40	0.48	0.52	0.56	0.60	0.64	0.68	0.72	0.76	0.80	0.84	0.88	0.86	0.92	1.04	1.12	1.16	1.20
90	0.36	0.36	0.45	0.54	0.59	0.63	0.68	0.72	0.77	0.81	0.86	0.90	0.95	0.99	0.97	1.04	1.17	1.26	1.31	1.35
100	0.40	0.40	0.50	0.60	0.65	0.70	0.75	0.80	0.85	0.90	0.95	1.00	1.05	1.10	1.08	1.15	1.30	1.40	1.45	1.50
120	0.48	0.48	0.60	0.72	0.78	0.84	0.90	0.96	1.02	1.08	1.14	1.20	1.26	1.32	1.30	1.38	1.56	1.68	1.74	1.80
140	0.56	0.56	0.70	0.84	0.91	0.98	1.05	1.12	1.19	1.26	1.33	1.40	1.47	1.54	1.51	1.61	1.82	1.96	2.03	2.10
160	0.64	0.64	0.80	0.96	1.04	1.12	1.20	1.28	1.36	1.44	1.52	1.60	1.68	1.76	1.73	1.84	2.08	2.24	2.32	2.40
180	0.72	0.72	0.90	1.08	1.17	1.26	1.35	1.44	1.53	1.62	1.71	1.80	1.89	1.98	1.94	2.07	2.34	2.52	2.61	2.70
200	0.80	0.80	1.00	1.20	1.30	1.40	1.50	1.60	1.70	1.80	1.90	2.00	2.10	2.20	2.16	2.30	2.60	2.80	2.90	3.00
220	0.88	0.88	1.10	1.32	1.43	1.54	1.65	1.76	1.87	1.98	2.09	2.20	2.31	2.42	2.38	2.53	2.86	3.08	3.19	3.30
240	0.96	0.96	1.20	1.44	1.56	1.68	1.80	1.92	2.04	2.16	2.28	2.40	2.52	2.64	2.59	2.76	3.12	3.36	3.48	3.60
260	1.04	1.04	1.30	1.56	1.69	1.82	1.95	2.08	2.21	2.34	2.47	2.60	2.73	2.86	2.81	2.99	3.38	3.64	3.77	3.90
280	1.12	1.12	1.40	1.68	1.82	1.96	2.10	2.24	2.38	2.52	2.66	2.80	2.94	3.08	3.02	3.22	3.64	3.92	4.06	4.20
300	1.20	1.20	1.50	1.80	1.95	2.10	2.25	2.40	2.55	2.70	2.85	3.00	3.15	3.30	3.24	3.45	3.90	4.20	4.35	4.50
320	1.28	1.28	1.60	1.92	2.08	2.24	2.40	2.56	2.72	2.88	3.04	3.20	3.36	3.52	3.46	3.68	4.16	4.48	4.64	4.80
340	1.36	1.36	1.70	2.04	2.21	2.38	2.55	2.72	2.89	3.06	3.23	3.40	3.57	3.74	3.67	3.91	4.42	4.76	4.93	5.10
360	1.44	1.44	1.80	2.16	2.34	2.52	2.70	2.88	3.06	3.24	3.42	3.60	3.78	3.96	3.89	4.14	4.68	5.04	5.22	5.40
380	1.52	1.52	1.90	2.28	2.47	2.66	2.85	3.04	3.23	3.42	3.61	3.80	3.99	4.18	4.10	4.37	4.94	5.32	5.51	5.70
400	1.60	1.60	2.00	2.40	2.60	2.80	3.00	3.20	3.40	3.60	3.80	4.00	4.20	4.40	4.32	4.60	5.20	5.60	5.80	6.00
420	1.68	1.68	2.10	2.52	2.73	2.94	3.15	3.36	3.57	3.78	3.99	4.20	4.41	4.62	4.54	4.83	5.46	5.88	6.09	6.30
440	1.76	1.76	2.20	2.64	2.86	3.08	3.30	3.52	3.74	3.96	4.18	4.40	4.62	4.84	4.75	5.06	5.72	6.16	6.38	6.60
460	1.84	1.84	2.30	2.76	2.99	3.22	3.45	3.68	3.91	4.14	4.37	4.60	4.83	5.06	4.97	5.29	5.98	6.44	6.67	6.90
480	1.92	1.92	2.40	2.88	3.12	3.36	3.60	3.84	4.08	4.32	4.56	4.80	5.04	5.28	5.18	5.52	6.24	6.72	6.96	7.20
500	2.00	2.00	2.50	3.00	3.25	3.50	3.75	4.00	4.25	4.50	4.75	5.00	5.25	5.50	5.40	5.75	6.50	7.00	7.25	7.50

Pipe length baseline temperature = 0°F

Pipe length in feet

The Engineers Toolbox (www.engineeringtoolbox.com)—Expansion of Carbon, Copper and Stainless Steel Pipe

Figure 43: Coiled Expansion Loops and Offsets

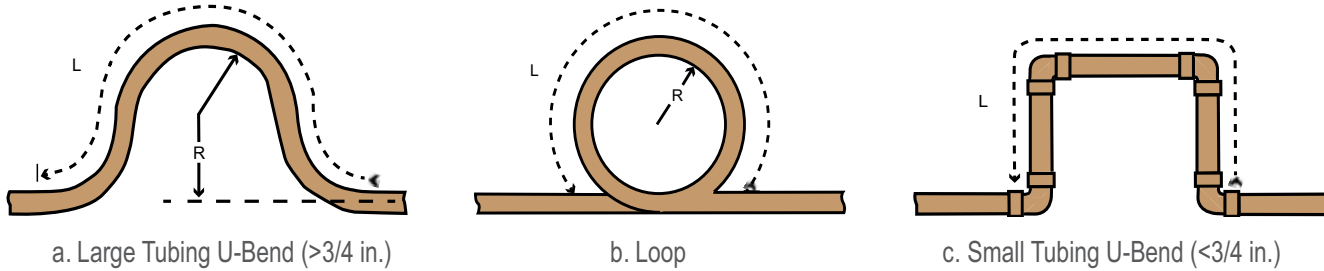


Table 29: Radii of Coiled Expansion Loops and Developed Lengths of Expansion Offsets

Anticipated Linear Expansion (LE) (in)		Nominal Tube Size (OD) inches						
		1/4	3/8	1/2	3/4	1	1-1/4	1-1/2
1/2	R ¹	6	7	8	9	11	12	13
	L ²	38	44	50	59	67	74	80
1	R ¹	9	10	11	13	15	17	18
	L ²	54	63	70	83	94	104	113
1-1/2	R ¹	11	12	14	16	18	20	22
	L ²	66	77	86	101	115	127	138
2	R ¹	12	14	16	19	21	23	25
	L ²	77	89	99	117	133	147	160
2-1/2	R ¹	14	16	18	21	24	26	29
	L ²	86	99	111	131	149	165	179
3	R ¹	15	17	19	23	26	29	31
	L ²	94	109	122	143	163	180	196
3-1/2	R ¹	16	19	21	25	28	31	34
	L ²	102	117	131	155	176	195	212
4	R ¹	17	20	22	26	30	33	36
	L ²	109	126	140	166	188	208	226

R = Centerline Minimum Radius (inches)

L = Centerline Length of Pipe

The Engineers Toolbox (www.engineeringtoolbox.com)—Expansion of Carbon, Copper and Stainless Steel Pipe

Refrigerant Pipe Connections

⚠ Note: When routing field-provided tubing inside the outdoor unit case, take care to avoid vibration damage to the tubing. Mount the tubing so it does not make contact with the compressor, unit casing, terminal cover, or mounting bolts. Allow room for field installation.

Properly insulate field-provided tubing inside the confines of the unit casing.

Refer to Figure 44 for unit pipe connection options and Table 27 for outdoor unit connection types.

Figure 44: Outdoor Unit—Refrigerant Pipe Connections Options

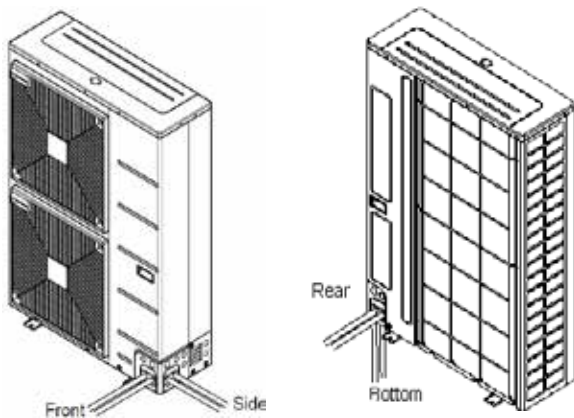


Table 30: Outdoor Unit Refrigerant Pipe Connections

Model	Liquid Conn (inches)	Type	Vapor Conn (inches)	Type
ARUN036GS2	3/8	Braze	5/8	Braze
ARUN047GS2	3/8	Braze	5/8	Braze
ARUN053GS2	3/8	Braze	3/4	Braze

Pipe Supports

A properly installed pipe system should be adequately supported to avoid pipe sagging. Sagging pipes become oil traps that could lead to equipment malfunction. Field-provided pipe supports should be designed to meet local codes. If allowed by code, use fiber straps or split-ring hangers suspended from the ceiling on all-thread rods. Supports should never touch the pipe wall. Insulate the pipe first. Place a second layer of insulation over the pipe insulation jacket to prevent chafing and compression of the primary insulation within the confines of the support pipe clamp. Pipe and insulation should be allowed to move linearly as pipe temperature changes.

- Straight segments up to 3/4 inch OD should be supported at least every 5 feet or per local codes if more stringent.
- Straight segments of 1 inch OD and larger copper pipe should be supported every 6 feet or per local codes if more stringent.
- A properly installed pipe system will have sufficient supports to keep pipes from sagging during the life of the system. As necessary, place supports closer for segments where potential sagging could occur.

Wherever the pipe changes direction, place a hanger within 12 inches on one side and within 12 to 19 inches of the bend on the other side as shown in Figure 45. Support piping at indoor units as shown in Figure 46. Support Y-Branch and Header fittings as shown in Figure 47 and Figure 48.

Figure 45: Typical Pipe Support—Change in Pipe Direction

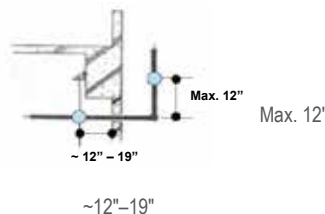


Figure 46: Pipe Support at Indoor Unit

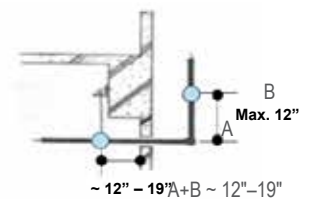


Figure 47: Pipe Support at Y-Branch Fitting

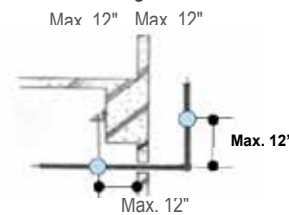
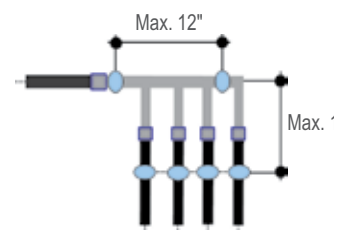


Figure 48: Pipe Support at Header



Routing / Protecting Refrigerant Pipe

▲ Note: Power cables and low voltage control wiring should be separated a minimum of 2 inches to avoid Electro-Magnetic Field (EMF) effects on communications. See Figure 49 and Figure 50.

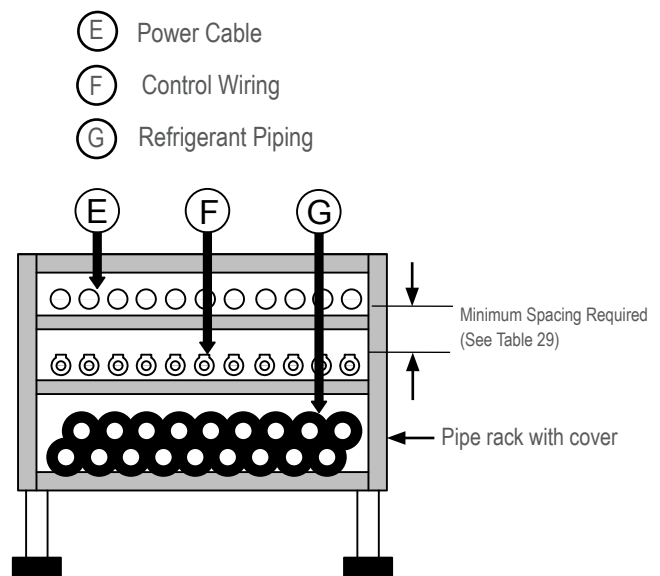
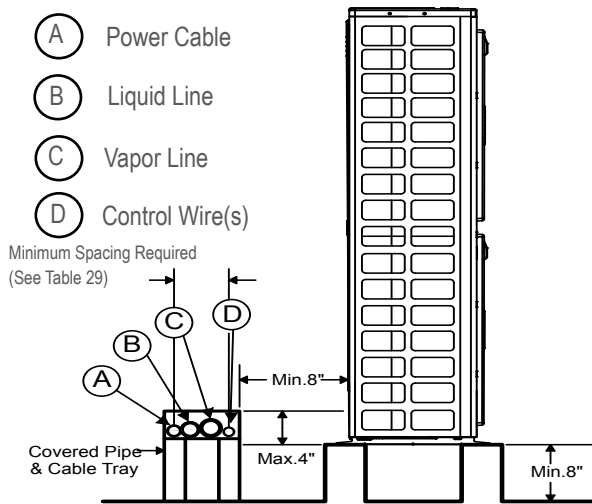
When placing multiple outdoor units in the same vicinity, a multiple tier pipe/cable tray similar to the one shown in Figure 50 may be a good option. Position refrigerant pipe, power cables, and communication cables so they do not impede walking access to the unit or the removal of service access panels. Best practice dictates that insulated piping and cables should be properly supported and protected from natural elements to prevent deterioration. Place pipes, cables, and wires in a cable/pipe tray equipped with a removable weather tight cover. Consider "Copper Expansion and Contraction" on page 70.

The minimum size wall sleeve or utility conduit should be sized using the data in Table 28, local code, and NEC regulations. Size using the most conservative data.

Figure 49: Single outdoor unit—suggested arrangement of refrigerant pipe and cable

Figure 50: Multiple outdoor unit installation—suggested arrangement of refrigerant pipe and cables using a multi-tier tray system

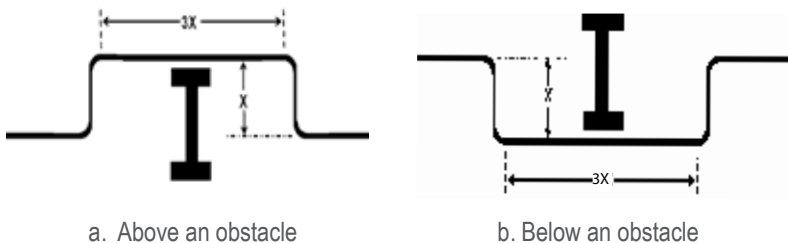
System Engineering



Handling Obstacles

When an obstacle, such as an I-Beam or Concrete T, is in the path of the planned refrigerant pipe run, it is best practice to route the pipe over the obstacle. If adequate space is not available to route the insulated pipe over the obstacle, route the pipe under the obstacle. In either case, it is imperative the horizontal section of pipe above or below the obstacle be a minimum of 3 times greater than the longest vertical rise (or fall) distance.

Figure 51: Installing piping above and below an obstacle



Underground Refrigerant Piping

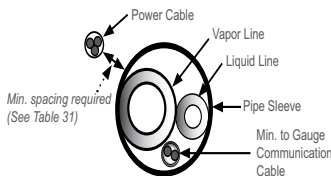
Refrigerant pipe installed underground should be routed inside a vapor tight protective sleeve to prevent insulation deterioration and water infiltration. Refrigerant pipe installed inside underground casing should be continuous without joints. Underground refrigerant pipe and conduit must be located at a level below the frost line.

Table 31: Utility Conduit Sizes

		Vapor Pipe		
		1/2" (2.0 ^{2.5})	5/8" (2-1/8 ^{2.5})	3/4" (2-1/4 ^{2.5})
Liquid Pipe	1/4" (1.0 ³)	4	4	4
	3/8" (1-1/8 ³)	4	4	5
	1/2" (1-1/2 ⁴)	5	5	5
	5/8" (1-5/8 ⁴)	5	5	5
	3/4" (1-3/4 ⁴)	5	5	5

1. OD Pipe diameter in inches.
2. Values in parenthesis () indicate OD of pipe with insulation jacket.
3. Diameter of pipe with insulation. Thickness of pipe insulation is typical. Actual required thickness may vary based on surrounding ambient conditions and should be calculated and specified by the design engineer.
4. Liquid line with 3/8" thick insulation.
5. Liquid line with 1/2" thick insulation.

Figure 52: Typical arrangement of refrigerant pipe and cable(s) in a utility conduit



If the lines are laid inside a multi-conduit chase, consider these factors when grouping various elements together:

- Power lines (including power supply to air conditioner) and communication cables must not be laid inside the same conduit.
- In the same way, when grouping, power and communication cables should not be bunched together.

Table 32: Required Separation Between Power and Control Wiring

Current capacity of power line		Spacing
100V or more	10A	11-7/8 inch
	50A	19-5/8 inch
	100A	39-1/4 inch
	Exceed 100A	59 inches

Based on a maximum 328 foot power cable. Increase spacing proportionally for cables beyond 328 feet.

If power is known to be dirty, the recommended spacing in the table should be increased.

No Pipe Size Substitutions

Use only the pipe size selected by LATS Multi V software. See "LATS Multi V" on page 61. Installing a different size than specified by LATS is prohibited and may result in a system malfunction or failure to work at all.

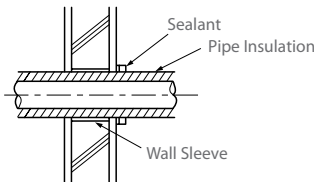
Pipe Bends

Use long radius bends when bending soft copper. Refer to Table 28 on page 72 for minimum radius specifications.

Pipe Sleeves and Wall Penetrations

LG requires that all pipe penetrations through walls and floors must be properly insulated. Route pipe through a wall using an appropriately sized wall sleeve. A properly sized sleeve prevents the compression of refrigerant pipe insulation and allows the pipe to move freely within the sleeve.

Figure 53: Typical pipe penetration



Installation of Refrigerant Pipe/Brazing Practices

1. LG indoor and outdoor units contain capillary tubes, orifices, electronic controlled expansion valves, oil separators, and heat exchangers that can easily become blocked if debris, such as copper burrs, slag, and carbon dust is introduced to the pipe system during installation. Keep the piping system free of contaminants. Filter dryers cannot be used.
 - a. Store pipe stock in a dry place.
 - b. Keep stored pipe capped and clean.
 - c. Blow all pipe sections clean with dry nitrogen prior to assembly.
 - d. De-bur and clean all cuts before assembly.
2. Proper system operation depends on the installer using best practices and the utmost care while assembling the piping system.
 - a. Use adapters to assemble different sizes of pipe.
 - b. Do not use flux, soft solder, or anti-oxidant agents.
 - c. Use a tubing cutter. Do not use a hacksaw to cut pipe.
3. When brazing, always use a dry nitrogen purge and maintain a steady flow while brazing.
4. When brazing, use a 15% silver phosphorous copper brazing alloy, such as Stay-Silv 15, to avoid overheating and produce good flow.
5. Protect heat sensitive components while brazing. Use a wet rag or a Cool Gel™ type product when located near brazing operations.

Refrigerant Pipe System Insulation

The liquid and vapor lines must be insulated separately. All refrigerant piping, including Y-Branch and Header fittings, field-provided isolation ball valves, service valves, elbows, and other specialties must be thoroughly insulated using a closed-cell insulation, such as Armaflex or equivalent. All joints must be glued with no air gaps. Insulation material must fit snugly against the refrigeration pipe with no air space between the pipe and insulation material. Insulation passing through pipe hangers, inside conduit and/or wall sleeves should not be compressed. Protect insulation inside hangers and supports with a second layer of insulation. All pipe insulation exposed to direct sun light and/or deterioration producing elements should be covered with a PVC or aluminum vapor barrier jacket, or alternatively placed in a weather resistant enclosure, such as a pipe rack with a top cover. See Figures 49 and 50 on page 74.

The design engineer should perform calculations to determine if the factory supplied insulation jackets have sufficient thickness to meet local codes and avoid sweating at jobsite conditions. Technical data on factory insulation can be found in the Cut Sheet section—"Y-Branch Kits" on page 84 and "Header Kits" on page 5. Add additional insulation if necessary. Check the fit of the insulation jacket provided with the LG Y-Branch and Header kits after all pipes are brazed to fittings. Mark all pipes at the point where the insulation jacket ends. Remove the jacket. Install field-provided insulation on pipes segments first. Then install the LG provided insulation plugs on the ends of all unused Header ports. Then apply clamshell insulation on jackets to Y-Branches and Header fittings. Peel the adhesive glue protector strips from the insulation jacket and install the clam-shell jacket over the fitting.

Figure 54: System Control Board

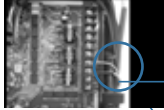
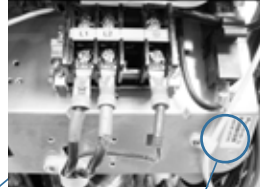


Figure 55: Communication Ground Termination²



Figure 56: Power Wire Terminations
L1 = left
L2 = center
Earth Gnd = right



Power Wiring

Route control wiring and power wiring in separate conduits. All wiring must conform to NEC and local codes. Unit disconnect and wiring is field supplied.

Communication Cables

See Figure 55, Figure 56, and Figure 57.

See page 74 for all low voltage wiring termination details.

Lightning Protection

Field-supplied where applicable. Installed per local code.

Figure 57: Communication Cable Separated from Power Wiring



Figure 58: Refrigerant Pipe Connection Point¹



Figure 59: Refrigerant Pipe and Electrical Knockouts




Fused Disconnect provided by others

▲ Note:

1. For detailed information, refer to "Dimensional Data and Weights" on page 3 and "Pipe and Electrical Connections" on page 4 for exact location of pipe and electrical connections.
2. Minimum 18 AWG, shielded, stranded, 2 conductor or size per local code (whichever is larger).
3. Refer to Table 2 on page 15 for full load ampere ratings. Size all wiring and field-provided components per local codes.

JOBSITE CONNECTIONS

Low Voltage Wiring

Figure 60: Communications Wiring Terminals

- A. Use 2-conductor stranded and shielded wire with the shield grounded at the outdoor unit.
- B. Connect the communications cable between indoor units using a daisy chain configuration only. "Star" or "home run" control wiring connections involving soldering or wire caps are not permitted.
- C. Minimum 18 AWG, 2 conductor stranded shielded copper cable only.
- D. Provide separate conduits for control wiring and power wiring.
- E. Power and communications cables must not be routed in the same conduit and must be routed in a manner that does not cause communication problems. For more information, refer to Table 29 on page 75.
- F. Connect outdoor unit terminal IDU-A to the odd numbered indoor unit terminal. Terminal "A" on the indoor units may be tagged 3(A) or 5(A).
- G. Connect outdoor unit terminal IDU-B to indoor unit terminal "B". Terminal "B" on the indoor units may be tagged 3(B) or 5(B).
- H. Maximum allowed length of indoor unit communication cable is 984 feet.

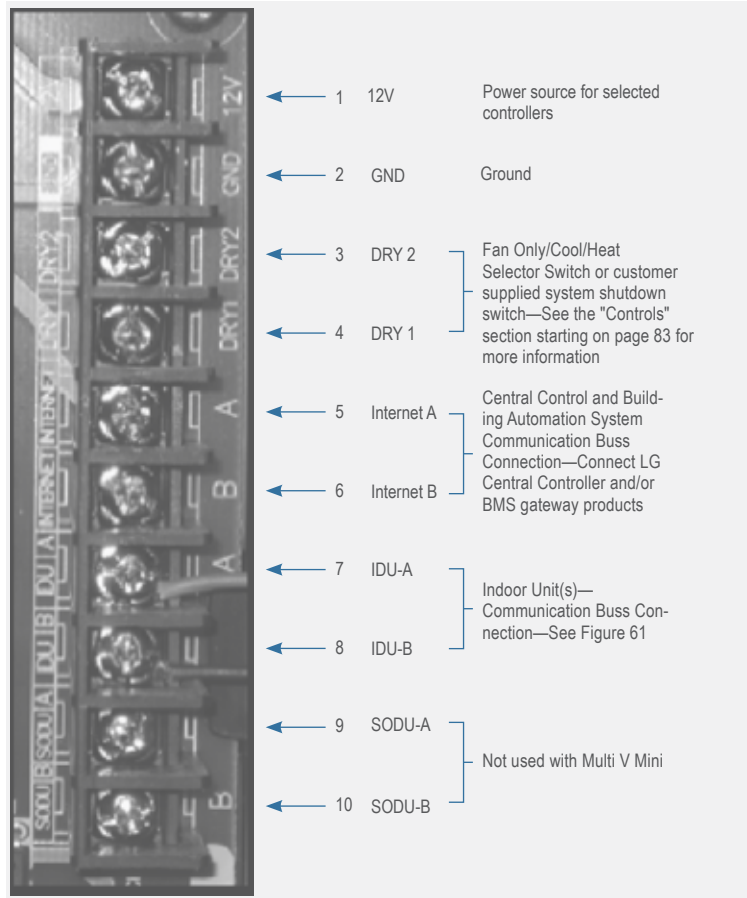
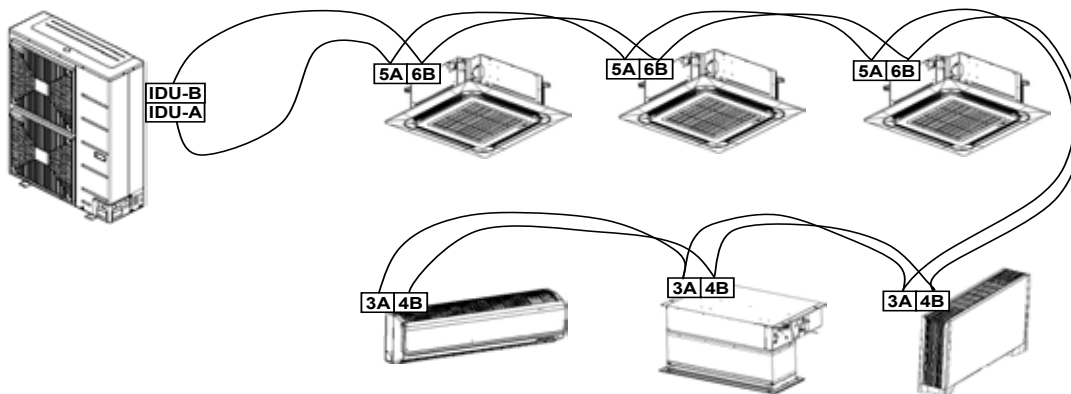


Figure 61: Multi V System—Daisy-Chain Communications Cable Wiring



▲ Note:

- 1. Communications cable shield is grounded at ODU only.
- 2. Maintain polarity throughout the communication network.

Consider refrigerant safety in all designs. Refer to "ASHRAE Standards Summary" on page 88 for information on how to meet the requirements of ASHRAE Standard 15 and 34.

To properly charge a Multi V Mini system, it is imperative to know the "as-built" physical length of each segment of the liquid line. The installer must also have an accurate count of the types and sizes of refrigerant pipe fittings used to build the system's liquid line.

1. Make a copy of Table 30.
2. Create an as-built drawing of the system's liquid line or mark up a tree mode piping diagram from LATS Multi V. Document the linear feet of straight pipe and the quantity and type of each fitting by pipe diameter.
3. Calculate the total linear feet of liquid line tubing in the system. Record the values using lines 1–3 in Table 30.

4. Count the number of indoor units. Group them by model type and *nominal* capacity.
5. Group indoor units by size as indicated in the description fields on lines 4–29 of Table 30. Record the quantity of units in each group on the appropriate lines.
6. If the outdoor unit is a *nominal* 36k, record a negative 1.1 lbs in the "Total" field on line 31.

Calculate the System Refrigerant Charge

7. Sum the Total column values on lines 1-31 and place in the field labeled System Trim Charge.
8. If the value of the trim charge is positive, add refrigerant. If negative, remove refrigerant.
9. Add the Outdoor Unit Factory Charge to the Trim Charge. This is the System Charge. Record in the appropriate field.

MINI REFRIGERANT CHARGE



Refrigerant Charge—ARUN 036, 047, 053

Table 33: System Refrigerant Charge Calculator (lbs.)

System Tag or ID _____		Job Name _____				
		Project Manager _____				
		Date _____				
Line #	Description	Chassis I.D.	Size	Quantity	CF (Ref.) ¹	Total (lbs.)
1	Linear feet of 1/4" liquid line tubing ²	—	—		0.015	
2	Linear feet of 3/8" liquid line tubing ²	—	—		0.041	
3	Linear feet of 1/2" liquid line tubing ²	—	—		0.079	
4	Wall Mounted + Art Cool Mirror	SB, SE	5k to 15k		0.53	
5	Wall Mounted + Art Cool Mirror	SC, S8	18k to 24k		0.62	
6	1-Way Cassette	TU	7k to 12k		0.44	
7	1-Way Cassette	TT	18k to 24k		0.64	
8	2-Way Cassette	TL	18k to 24k		0.35	
9	4-Way 2' x 2' Cassette	TR	5k to 7k		0.40	
10	4-Way 2' x 2' Cassette	TR	9k to 12k		0.55	
11	4-Way 2' x 2' Cassette	TQ	15k to 18k		0.71	
12	4-Way 3' x 3' Cassette	TNA	7k to 24k		0.89	
13	4-Way 3' x 3' Cassette	TPC	24k to 28k		1.06	
14	4-Way 3' x 3' Cassette	TMA	24k to 36k		1.08	
15	4-Way 3' x 3' Cassette	TNC	36k		1.41	
16	4-Way 3' x 3' Cassette	TMC	42k to 48k		1.41	
17	High Static Ducted	BG	7k to 42k		0.97	
18	High Static Ducted	BR	48k		1.34	
19	Low Static Ducted	L1	7k to 9k		0.31	
20	Low Static Ducted	L2	12k to 18k		0.42	
21	Low Static Ducted	L3	24k		0.55	
22	Low Static Ducted Bottom Return	B3	7k to 15k		0.37	
23	Low Static Ducted Bottom Return	B4	18k to 24k		0.82	
24	Vertical / Horizontal Air Handling Unit	NJ	12k to 30k		1.04	
25	Vertical / Horizontal Air Handling Unit	NJ	36k		1.57	
26	Vertical / Horizontal Air Handling Unit	NK	42k to 54k		2.00	
27	Ceiling Suspended	VJ	18k to 24k		0.77	
28	Convertible Surface Mount—Ceiling / Wall	VE	9k to 12k		0.22	
29	Floor Standing	CE (U)	7k to 15k		0.37	
30	Floor Standing	CF (U)	18k to 24k		0.82	
31	Outdoor Unit Factory Refrigerant Charge (Choose One)	ARUN 036 ODU			-1.1	
		ARUN 047 ODU			0	
		ARUN 053 ODU			0	
Trim Charge (lbs.) (sum lines 1-30)						
ODU Factory Charge ARUN 036, 047, 053						6.6
System Charge, Total of Trim and Factory Chage (lbs.)						

- For charging purposes, consider only the liquid line, ignore the vapor line.
- Maximum quantity of indoor units allowed:
ARUN 036 = 6
ARUN 047 = 8
ARUN 053 = 9
- If trim charge is negative, remove refrigerant.
- If trim charge is positive, add refrigerant.
- Take appropriate actions at the end of the equipment's useful life to recover, recycle, reclaim, or destroy R410A refrigerant according to applicable US EPA rules.

System Engineering

CUT SHEETS

"Dimensional Data and Weights" on page 82

"Pipe and Electrical Connections" on page 83

"Y-Branch Kits" on page 82

"Header Kits" on page 83

CUT-SHEET

Dimensional Data and Weights

Figure 62: Unit Dimensions

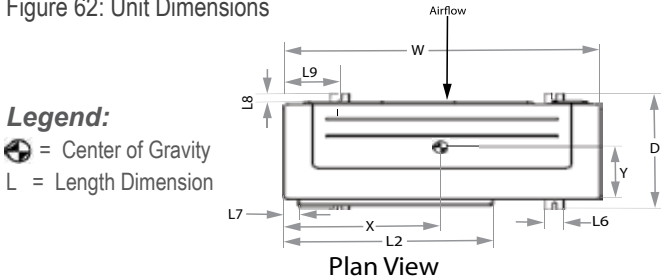
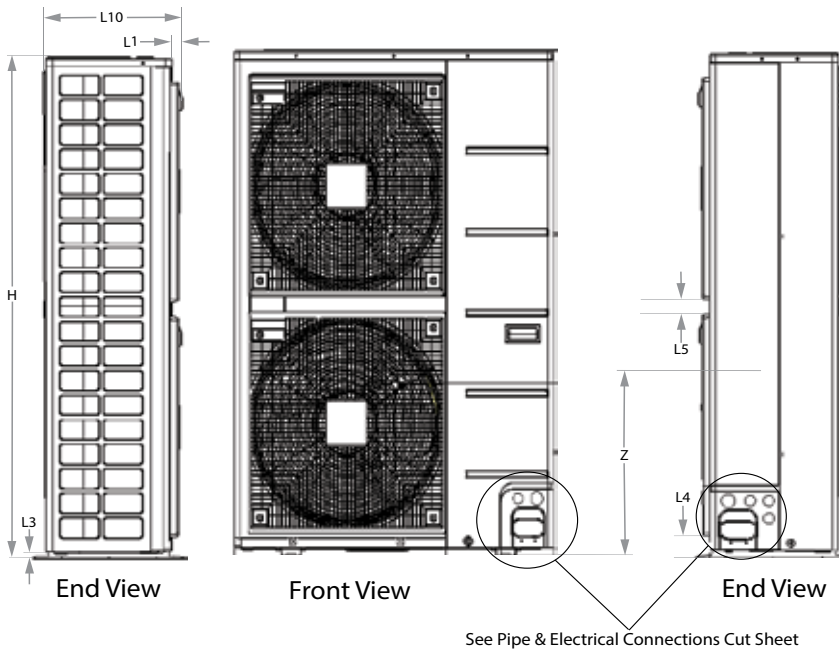


Table 34: Unit Weight Information (lbs)

Model	Operating	Shipping	Mounting Point Weights			
			1	2	3	4
ARUN036GS2	234	258	87	33	83	31
ARUN047GS2	234	258	87	33	83	31
ARUN053GS2	234	258	87	33	83	31



W (Width)	37-13/32
H (Height)	54-1/4
D (Depth)	15-11/32
L1	1-1/4
L2	24-23/32
L3	15/16
L4	1-7/16
L5	1-9/16
L6	2-7/16
L7	1-9/16
L8	1-5/16
L9	6-9/16
L10	13-1/32
Center of Gravity	
X	10-3/16
Y	6-11/16
Z	21-15/32

Figure 63: Maintenance and Air Flow Clearances

⚠ Note: The arrows show the direction of airflow.

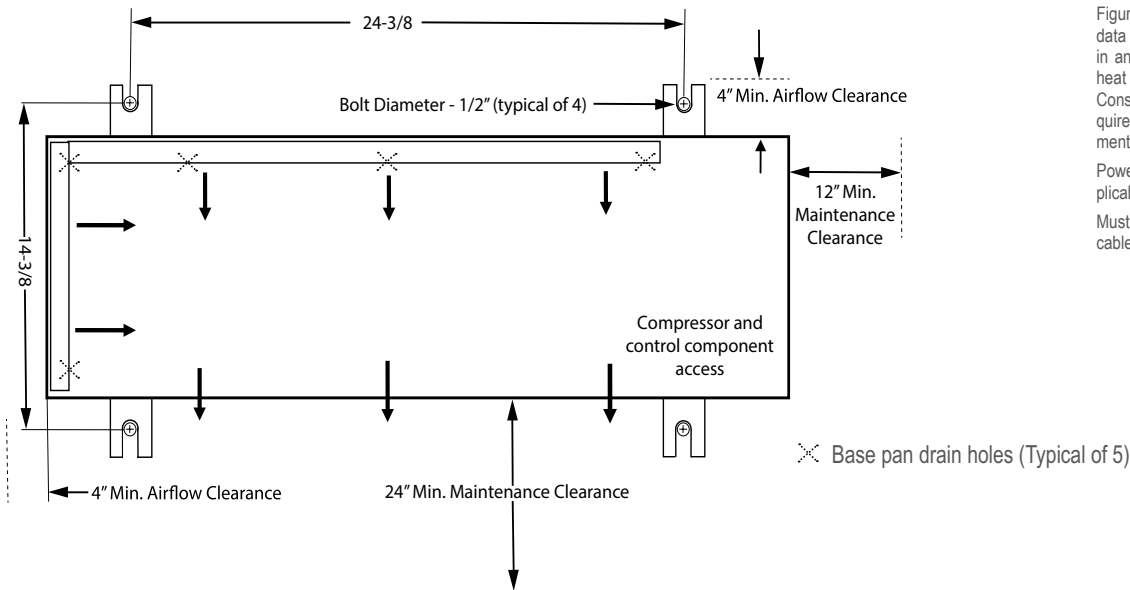


Image not to scale. All dimensions ± 0.25 inches.

Consult NEC for required electrical clearances.

Figure 63 depicts the minimum airflow clearance data provided is for a single unit installation placed in an open area without overhangs or near other heat rejecting equipment. Refer to "Placement Considerations" on page 57 or "Clearance Requirements" on page 59 for minimum requirements for complex installation scenarios.

Power wiring cable size must comply with the applicable local and national code.

Must follow installation instructions in the applicable LG installation manual.

CUT-SHEET

Pipe and Electrical Connections

Figure 64: 036, 047, 053 Piping Options—Front/Side Connections

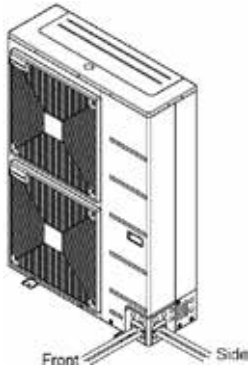


Figure 65: 036, 047, 053 Piping Options—Rear Connections

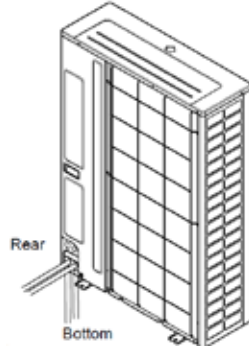


Table 35: Outdoor Unit Pipe Connections (in.)

Model	Liquid		Vapor	
	Conn	Type	Conn	Type
ARUN036GS2	3/8"	Braze	5/8"	Braze
ARUN047GS2	3/8"	Braze	5/8"	Braze
ARUN053GS2	3/8"	Braze	3/4"	Braze

Figure 66: 036, 047, 053 Front Connections

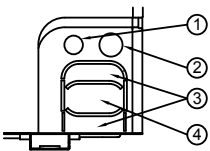


Figure 67: 036, 047, 053 Rear Connections

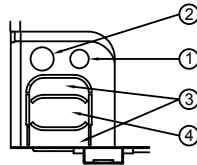


Figure 68: 036, 047, 053 Side Connections

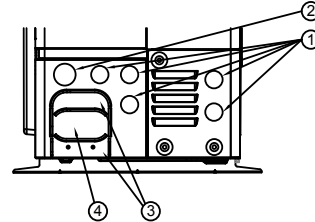


Table 36: Outdoor Unit Wiring Connections

ID	Description	Use	Notes
1	1.0" Knockout	• Power or communications conduit	Use rubber or polymeric resin grommets.
2	1-1/4" Knockout	• Liquid line connection	
3	4"x5" Cutout	• Bundled pipe connection	• Keep pests out. Fill area around pipe bundle with spray foam and suitable weather tight cover. • Gasket rough metal edges to protect pipe and wire chaffing.
4	4"x2" Cutout	• Power and communications wiring	

Figure 69: 036, 047, 053 Front Connection Detail

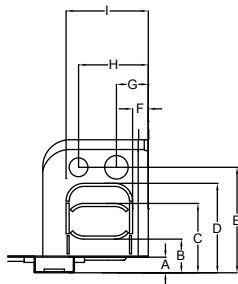


Figure 70: 036, 047, 053 Rear Connection Detail

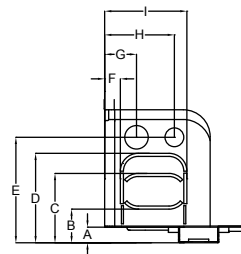


Figure 71: 036, 047, 053 Side Connection Detail

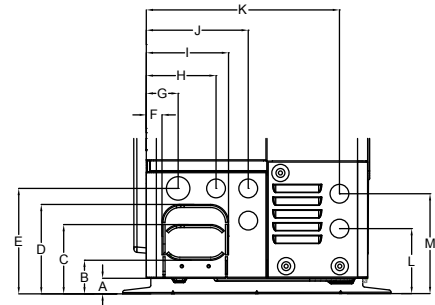


Table 37: ARUN 036, 047, and 053 Piping and Electrical Connection Dimensions (in.)

	A	B	C	D	E	F	G	H	I	J	K	L	M
Front	1.0	2-1/4	4-1/8	5-3/16	6-3/8	1.0	1-7/8	4-1/8	4-11/16	—	—	—	—
Rear	1.0	2.0	3-7/8	5-3/16	6-3/8	1.0	1-7/8	3-11/16	4-11/16	—	—	—	—
Side	1.0	2-1/4	4-1/8	5-3/16	6-3/8	1.0	1-7/8	4-1/8	4-11/16	6.0	11-7/16	3-7/8	5-7/8

CUT-SHEET

Y-Branch Kits

Figure 72: Y-Branch connectors (Table 35)

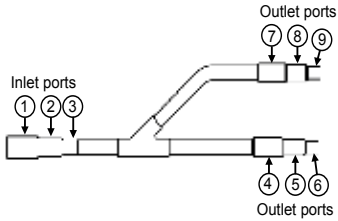
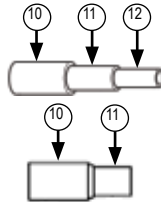


Figure 73: Reducer parts (Table 37)



Nominal Capacity Range (Values expressed in BTUs)

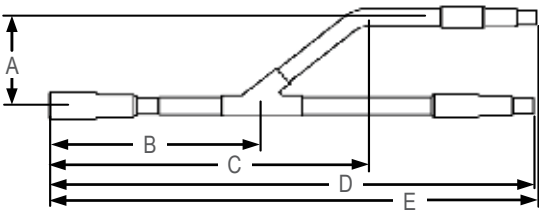
Model	Fitting Capacity
ARBLN1621	≤ 54,600 connected capacity
ARBLN03321	≤ 76,400 connected capacity

Values expressed in BTUs

Fitting Properties

Material	Copper
Design Pressure	551 psig

Figure 74: Y-Branch connection dimensions (Table 36)



Insulation Jacket Properties

Material	Polyolefin Foam
UL94 Flame Classification	HF-1
Density	1.84 lbm/ft ³
Thermal Conductivity	.0208 Btuh/ft °R
Thickness	0.5 Inches

Table 38: Y-Branch Connection Diameters (in-ID) (Reference Figure 72)

Model	Y-Branch Type	Port Identifier								
		1	2	3	4	5	6	7	8	9
ARBLN01621	Liquid	—	1/4	3/8	3/8	1/4	—	3/8	1/4	—
	Vapor	—	5/8	1/2	1/2	5/8	—	1/2	5/8	—
ARBLN03321	Liquid	—	1/2	3/8	3/8	1/2	1/4	3/8	1/2	1/4
	Vapor	1	7/8	3/4	5/8	3/4	1/2	5/8	3/4	1/2

ID = Inside Diameter

Table 39: Y-Branch Dimensions (in) (Reference Figure 74)

Model	Y-Branch Type	A	B	C	D	E
ARBLN01621	Liquid	2-29/32	6-9/16	8.0	11-1/16	11-1/2
	Vapor	2-29/32	4-1/2	8.0	11-1/16	11-1/2
ARBLN03321	Liquid	2-29/32	4-1/2	8.0	12-5/8	13-1/16
	Vapor	3-9/32	6-29/32	10-29/32	15-11/32	16-1/4

Table 40: Reducer Diameters (in) (Reference Figure 73)

Model	Qty/Kit	Reducer type	Port Identifier			
			10	11	12	Length
ARBLN01621	2	Liquid	1/2 ID	3/8 OD	—	2-3/4
		Vapor	3/4 ID	5/8 OD	—	2-3/4
ARBLN03321	3	Liquid	—	—	—	—
		Vapor	1-1/8 ID	1 OD	—	3-5/32
			7/8 ID	3/4 OD	—	2-3/4
			1 ID	7/8 ID	3/4 OD	4-11/32

The Y-Branch kits include a Polyolefin foam, clam shell, peel and stick, insulation jacket for each Y-Branch.

LG Y-Branch fittings must be used. Field-supplied branch fittings are not permitted.

Kit components must be kept free of debris and dry before installation.

ID = Internal Diameter, OD = Outside Diameter
All dimensions in inches. Tolerance ± 0.25 inch.

Images are not to scale.

Must follow installation instructions in the applicable LG installation manual.

Figure 75: 4-Port Header pipe connections (See Table 39)

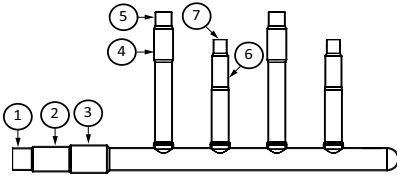


Figure 76: 4-Port Header dimensions (See Table 38)

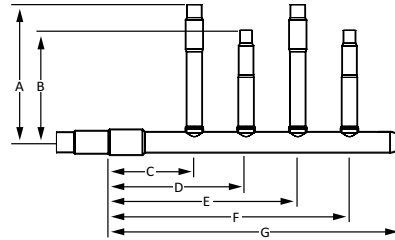


Figure 77: 7-Port Header pipe connections (See Table 39)

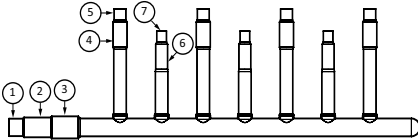
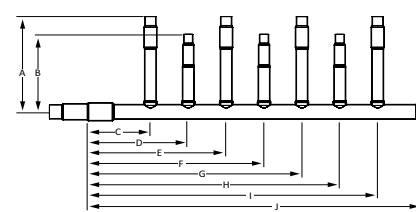


Figure 78: 7-Port Header dimensions (See Table 38)



Nominal Capacity Range

Model	Fitting Capacity	Port Capacity
ARBL054	≤ 54,600 connected capacity	≤ 54,600 per port
ARBL057	≤ 76,400 connected capacity	≤ 54,600 per port
ARBL104	≤ 160,400 connected capacity	≤ 76,400 per port
ARBL107	< 160,400 connected capacity	< 76,400 per port

Values expressed in BTUs

Fitting Properties

Material	Copper
Design Pressure	551 psig

Insulation Jacket Properties

Material	Polyolefin Foam
UL94 Flame Classification	HF-1
Density	1.84 lbm/ft ³
Thermal Conductivity	.0208 Btu/h/ft °R
Thickness	0.5 Inches

Table 41: Header Dimensions (in)

Model	Header Type	A	B	C	D	E	F	G	H	I	J
ARBL054 (4 port)	Liquid	5-29/32	4-23/32	4-3/4	7	9-1/2	11-4/5	14-5/32	—	—	—
	Vapor	5-29/32	4-23/32	4-3/4	7	9-1/2	11-4/5	14-5/32	—	—	—
ARBL057 (7 port)	Liquid	5-29/32	4-23/32	4-3/4	7	9-1/2	11-4/5	14-5/32	16-1/2	19	21-1/4
	Vapor	5-29/32	4-23/32	4-3/4	7	9-1/2	11-4/5	14-5/32	16-1/2	19	21-1/4
ARBL104 (4 port)	Liquid	5-29/32	4-23/32	4-3/4	7	9-1/2	11-4/5	14-5/32	—	—	—
	Vapor	5-29/32	4-23/32	6-3/10	8-3/5	11	13-2/5	15-23/32	—	—	—
ARBL107 (7 port)	Liquid	5-29/32	4-23/32	4-3/4	7	9-1/2	11-4/5	14-5/32	16-1/2	19	27-9/16
	Vapor	5-29/32	4-23/32	6-3/10	8-3/5	11	13-2/5	15-23/32	18-1/10	20-1/2	22-27/32

Table 42: Header Connection Diameters (in)

Model	Header Type	Port Identifier						
		1	2	3	4	5	6	7
ARBL054	Liquid	—	3/8	1/2	3/8	1/4	1/4	3/8
	Vapor	—	5/8	3/4	5/8	1/2	1/2	5/8
ARBL057	Liquid	—	3/8	1/2	3/8	1/4	1/2	5/8
	Vapor	—	5/8	3/4	5/8	1/2	1/2	5/8
ARBL104	Liquid	—	3/8	1/2	3/8	1/4	1/4	3/8
	Vapor	7/8	1	1-1/8	3/4	5/8	1/2	5/8
ARBL107	Liquid	—	3/8	1/2	3/8	1/4	1/4	3/8
	Vapor	7/8	1	1-1/8	3/4	5/8	1/2	5/8

A Header is a pipe that serves as a central connection for multiple runout pipe segments terminating at indoor units.
All dimensions in inches Internal Diameter. Tolerance ± 0.25 inch.

Shipped with plugging tubes (1/4 inch : 2 each, 1/2 inch : 2 each); Shipped with Insulation for plugging tube (4 pcs).

Shipped with plugging tubes (1/4 inch : 2 each, 1/2 inch : 2 each; 3/5 : 2 each); Shipped with Insulation for plugging tube (6 pcs).

All Headers are shipped with insulation (one each for vapor and liquid pipes).

U.S. DESIGN STANDARDS

"ASHRAE Standards Summary" on page 88

"Building Sustainability" on page 92

ASHRAE STANDARDS SUMMARY



ASHRAE Standard 15-2004 and ASHRAE Standard 34-2007

Members of the American Society of Heating, Refrigerating, and Air Conditioning Engineers (ASHRAE) have collaborated to develop voluntary standards to assist design professionals with:

- Industry best practices to safely use refrigerants
- Guidelines to properly ventilate commercial buildings using various technologies
- Proper control of building temperature and relative humidity
- Design building systems to minimize energy and water consumption

Table 43: ASHRAE Publications

Standard 15-2004	Safety Standard for Refrigeration Systems
Standard 34-2007	Designation and Safety Classification of Refrigerants
Standard 62.1-2010	Ventilation for Acceptable Indoor Air Quality

▲ Note: We are providing a summary of the standards impacting the design of the Multi V system or the safety of building occupants. Refer to the ASHRAE Standards for detailed design information.

Designing for Refrigerant Safety with Multi V—ASHRAE Standards 15 and 34

Standards 15-2004 and 34-2007 were developed to educate the design community on the safe use of refrigerants in commercial buildings and to address the classification of refrigerants. All Multi V systems use R410A refrigerant, which ASHRAE Standard 15-2004 and ASHRAE Standard 34-2007 classify in Safety Group “A1” and rate it as “neither” in the toxicity category titled “highly toxic or toxic under code classification.” These are the same ratings given to refrigerants R22, R134A, and R407C and are the safest ratings given in the standards to any refrigerant.

The displacement of oxygen in an occupied space could lead to occupant asphyxiation in the event of a catastrophic release of the entire system’s refrigerant charge. The standard allows a Refrigerant Concentration Limit (RCL) of 0.025 lbs/ft³ for R410A in most applications (refer to the standard for exceptions). The RCL rating indicates the allowable concentration (by weight) of refrigerant per cubic foot of room volume to avoid escape-impairing effects, such as oxygen deprivation, flammability, and cardiac sensitization.

▲ Note: This designation does not indicate that R410A is non-toxic. With high enough concentration levels, all refrigerants can be hazardous.

The standards are written to cover worst case scenarios and assume that the complete system charge is released into a confined space over a short period of time. If a refrigerant leak occurs, the actual concentration level in the confined space is dependent on the quantity of refrigerant in the equipment and the volume of air available for dispersion and dilution.

The total estimated charge of the refrigeration system is calculated by either LG’s LATS Multi V (see “LATS Multi V” on page 61) refrigerant piping design software or manually by following the procedure titled “Mini Refrigerant Charge” on page 76 and the “System Refrigerant Charge Calculator” worksheet on page 80. To apply the standard, the designer must first determine the occupied space with the smallest cubic volume served by the system.

*American Society of Heating, Refrigeration and Air Conditioning Engineers, Inc. (ASHRAE) Standard 15. 2007. Atlanta, GA. ASHRAE, Inc. Section 7.3.



Calculate the volume of air in each occupied space using the following guidelines to determine the dimensions of each space:

- Nonconnected Spaces** Where a refrigerating system or a part thereof is located in one or more enclosed occupied spaces that do not connect through permanent openings or HVAC ducts. Where different stories and floor levels connect through an open atrium or mezzanine arrangement, the volume used is determined by multiplying the floor area of the lowest space by 8.25 feet.*
- Ventilated Spaces** Where a refrigerating system or a part thereof is located within an air handler, an air distribution duct system, or an occupied space served by a mechanical ventilation system, the entire air distribution system shall be analyzed to determine the smallest volume area.*
- Closure** Closures in the air distribution system shall be considered. If one or more spaces of several arranged in parallel can be closed off from the source of the refrigerant leak, the volume(s) shall not be used in the calculation.*
Closure exceptions include smoke and fire dampers or combinations thereof that shut in an emergency and are not associated with a refrigerant leak, and dampers where airflow is never reduced below 10% of its maximum with the fan running.
- Plenums** The space above a suspended ceiling shall not be included in calculating the refrigerant quantity limit in the system unless such space is part of the air supply or return system.*
- Supply/Return Ducts** The volume of the supply and return ducts and plenums shall be included when calculating the refrigerant quantity limit in the system.*

Follow these steps to calculate the potential refrigerant concentration level:

1. Measure the occupied space dimensions (in feet).
2. Calculate the cubic foot volume of air in the smallest occupied space.
3. Divide the refrigerant charge of the Multi V system serving the area (lbs) by the results of step 2.
4. If the calculation indicates that the potential refrigerant concentration level is higher than the allowed RCL, increase the cubic volume of the smallest occupied space or modify the piping system design.
5. The allowable RCL limit for most applications must be equal to or less than 0.025 lbs/ft³. However, in special occupied spaces, such as hospitals and nursing homes, where occupants may have limited mobility, the allowable RCL limit is cut in half. See ASHRAE Standard 34-2007 and local code for detailed information.*

$$\text{RCL (lbs/ft}^3\text{)} = \frac{\text{System refrigerant charge (lbs)}}{\text{Volume of smallest occupied space (ft}^3\text{)}}$$

To determine the volume of an occupied space, the designer must determine which spaces are connected, not connected, or ventilated. Refer to Standard 34-2007 for help.

If the calculated RCL is above the allowable limit, there are two primary methods used to lower the RCL:

1. Increase the volume of the occupied space.
2. Decrease the size of the refrigerant charge.

Per Standard 34-2007, acceptable methods used to increase the volume of an occupied space include:*

- Install transfer ducts between rooms.
- Undercut doors.
- Include ventilation grilles in doors.
- Include the area above the ceiling as part of the return or supply air path.

* American Society of Heating, Refrigeration and Air Conditioning Engineers, Inc. (ASHRAE) 62.1-2010, sections 6.2 and 6.3

ASHRAE 62.1-2010—Ventilation for Acceptable Indoor Air Quality

Over the past twenty years, publications have documented that the occupant's well being, productivity, and comfort is significantly impacted if the building is not properly ventilated. Providing proper ventilation air directly and significantly increases a building's overall energy consumption and operating costs. In an effort to reduce medical and legal costs as well as the cost associated with personnel turnover, occupant companies and human resource personnel today consider the lease premium associated with tempering and cleaning ventilation air relatively insignificant. Standard 62.1-2010 is known as the Indoor Air Quality (IAQ) Performance Standard. The standard documents key strategies for maintaining minimum IAQ, including limiting the introduction of potential contaminants into the occupied areas originating from indoor and outdoor sources. The standard also addresses the proper introduction of ventilation (outdoor) air into the building using two methods:

1. The Ventilation Rate Procedure (VRP) is a prescriptive approach that sets minimum design requirements when sizing the building's ventilation equipment including:

- Outdoor air quality requirements
- Treatment procedures used if the outdoor air is deemed contaminated
- Volume of outdoor air that must be introduced to the occupied areas of commercial, institutional, vehicular, industrial, and residential buildings

2. The IAQ compliance procedures:

The standard, under section 6.3, allows the designer to significantly reduce the ventilation air volume required using the VRP procedure when high efficiency air filtration products designed to remove particulate and gas phase contaminants are specified. This procedure is a performance-based design approach where the indoor air quality in the occupied areas is actively monitored using sensing devices. When the IAQ falls below specified levels, the volume of outside air introduced into the building is modified.*

There are three methods used for ventilating buildings:

1. Mechanical "active" ventilation
2. Natural "passive" ventilation
3. Mixed-mode "active and passive" ventilation

The intent of this discussion is to provide guidance for the designer when applying active mechanical ventilation methods in conjunction with Multi V variable refrigerant flow equipment. Multi V indoor units are designed for quiet operation and room air recirculation. Inherently, quiet fans cannot produce a significant amount of static pressure. Thus, Multi V indoor units do not have the capability to "draw" ventilation air. Ventilation air must be "pushed" to the indoor unit. In all designs, the outside air must be introduced using a separate fan that is specifically designed for the task.

There are three methods to mechanically introduce outside air into individually occupied areas and rooms. When considering which method to use, the designer should choose a design that minimizes potential maintenance costs and operational problems.

Method 1: Decoupled Ventilation Air: This is the preferred method to use with all LG air conditioning products. From a common outside air inlet, filter and pre-treat the air temperature to room neutral conditions, and duct the ventilation air to the ceiling or wall registers in each breathing zone. Use this method when cost and operational problems are a priority. It can be used in all applications and in conjunction with any type of Multi V indoor unit. When using Method 1 and the outside air pre-treatment device experiences component failure due to filtering, heating, or cooling, the occupant will readily notice the resulting untreated air and can notify the building engineer of the problem. More importantly, the failure is less likely to impact the Multi V system.

USGBC. 2009. Green Building Design & Construction. Washington, DC. USGBC Staff. Page 535

* American Society of Heating, Refrigeration and Air Conditioning Engineers, Inc. (ASHRAE) 62.1-2010, sections 6.2 and 6.3

Method 2:

Coupled Pre-Treated Ventilation Air: From a common outside air inlet, filter and pre-treat the air temperature to room neutral conditions, and duct the ventilation air to the ceiling cassette or recessed-ducted Multi V indoor units. Multi V indoor units are designed for quiet operation and room air recirculation. Inherently, quiet fans cannot produce a significant amount of static pressure. Thus, Multi V indoor units do not have the capability to “draw” ventilation air. Ventilation air must be “pushed” to the indoor unit. Also, in the event the ventilation air is outside the indoor unit design parameters and the return and ventilation air streams fail to mix properly before entering the indoor unit coil, air stratification may occur causing erratic behavior of the Multi V indoor unit.

Operationally, the designer must consider many “what if” failure scenarios and understand the impact on building HVAC system operations. Negative building pressure conditions may impact the indoor unit fan’s ability to pass the proper amount of air over the indoor unit coil. This could occur if the ventilation system supply fan is disabled or ventilation dampers malfunction while the building exhaust fans continue to operate. In this case, the indoor unit coil may desperately need air as negative static pressure builds at the inlet of the indoor unit. On the other hand, when using non-ducted indoor unit models in conjunction with a constant flow of ventilation air and the Multi V indoor unit supply air volume is reduced below the ventilation air volume (the space temperature is satisfied), the ventilation air may flow backwards through the filter media and return air grille. Captured particulate from the filter media may discharge into the room.

Method 3:

Introduce Untreated Ventilation Air: From an outside air opening, duct filtered, untreated ventilation air to Multi V indoor units. This method can be employed in limited regions of the country where year round ambient conditions and air quality would provide the indoor unit mixed air within LG’s published acceptable conditions. Refer to the "Building Ventilation" on page 48 for more information.

BUILDING SUSTAINABILITY



USGBC—LEED Green Building Rating System

For decades, commercial building financial performance criteria influenced architects and engineers to focus on lowering the cost of construction. The trade-off for lower first-cost was higher energy consumption and poor indoor air quality. In recent years, with the advent of exploding fossil fuel costs and record litigation settlements related to poor indoor air quality, many designers have responded by adopting a new, more balanced design approach recognizing that designing with a long-term, sustainable perspective emphasizing first-cost, life-cycle cost, and the impact the development has on the environment will increase the building's value.

The American Society of Heating, Refrigerating, and Air Conditioning Engineers (ASHRAE) and the U.S. Green Building Council (USGBC) have been instrumental in developing and documenting voluntary best practice standards that provide the construction industry an all encompassing balanced approach for developing sustainable “green” buildings.



USGBC, a private organization, has developed holistic design standards for developing new and retrofitting existing buildings known as LEED® — Leadership in Energy and Environmental Design. The LEED Green Building Rating System is a voluntary, consensus-based program for developing high-performance, sustainable buildings. Based on well-founded scientific standards, LEED emphasizes state-of-the-art strategies for sustainable site development, water and energy conservation, and a guide for selecting construction materials that are easily renewable and manufactured to promote indoor environmental quality.

Table 44: LEED Green Building Certification Designations

LEED 2009 Rating System	New Construction, Core & Shell, and Schools ¹	Existing Buildings Operations and Maintenance ²	Commercial Interiors ³
Certified	40–49 credits	40–49 credits	40–49 credits
Silver	50–59 credits	50–59 credits	50–59 credits
Gold	60–79 credits	60–79 credits	60–79 credits
Platinum	80 credits and above	80 credits and above	80 credits and above

Products Developed for LEED® Generation

The Multi V variable refrigerant flow air conditioning system delivers state-of-the-art energy efficient performance making it easier for the design team to earn LEED certification. Choosing LG Multi V in lieu of traditional technologies, such as chillers and gas boilers, to heat and cool the building can have a positive impact on the design team's pursuit of the LEED credits listed in Table 44.

⚠ Note: Each LEED credit typically relates to numerous building design variables and building system parameters that, as a whole, allows the credit to be earned. No one product, or product manufacturer, including LG products, can guarantee credits.

References:

- USGBC. 2009. Green Building Design & Construction. Washington, DC. USGBC Staff. Page 535
- LEED® is a registered trademark of the U.S. Green Building Council.
- 1. LEED Reference Guide for Green Building Design and Construction—2009 Edition
- 2. LEED Reference Guide for Green Building Operations and Maintenance—2009 Edition
- 3. LEED Reference Guide for Green Interior Design and Construction—2009 Edition



Table 45: Potential LEED Credits using LG Multi V

Category	Point ID	Certification Paths					Point Description
		NC	CS	K12	CI	O&M	
WE	CR-4	–	–	0	1	1–2	Process water reduction
EA	PR-1	0	0	0	0	–	Basic building commissioning
EA	PR-3	0	0	0	0	0	Refrigerant has no CFC's (R410A)
EA	CR-1	1–19	3–21	1–19	–	1–18	Optimize energy performance
EA	CR-1.3	–	–	–	5–10	–	Optimize energy performance—HVAC
EA	CR-2	–	–	–	5	–	Enhanced commissioning
EA	CR-2.3	–	–	–	–	2	Exist bldg.—Ongoing commissioning
EA	CR-3	2	2	2	–	–	Enhanced commissioning
EA	CR-3.1	–	–	–	–	1	Perf. measurement—bldg. automation
EA	CR-3.2	–	–	–	–	1–2	Perf. measurement—Sys. level metering
EA	CR-4	2	2	1	–	–	Enhanced refrigerant management
EA	CR-5	–	–	–	–	1	Enhanced refrigerant management
EA	CR-3	–	–	–	2–5	–	Measure and verify—Tenant submetering
EA	CR-5.1	–	3	–	–	–	Measure and verify—Base building
EA	CR-5.2	–	3	–	–	–	Measure and verify—Tenant submetering
MR	CR-1.1	–	–	–	1	–	Tenant space—Long-term commitment
MR	CR-1	–	1–5	–	–	–	Maintain exterior walls, floor, roof
MR	CR-1.1	1–3	–	1–2	–	–	Maintain exterior walls, floor, roof
MR	CR-1.1	–	–	–	1–2	–	Maintain non-structural elements
MR	CR-1.2	1	–	1	–	–	Maintain non-structural elements
IEQ	PR-2	–	–	Yes	–	–	Minimum acoustical performance
IEQ	1.4	–	–	–	–	1	Reduce particulates—Occupied space
IEQ	1.5	–	–	–	–	1	Reduce particulates—Construction area
IEQ	3.1	–	–	–	1	–	Reduce particulates in air distribution
IEQ	CR-6	–	1	–	–	–	Controllability—Thermal comfort
IEQ	CR-6.2	1	–	1	1	–	Controllability—Thermal comfort
IEQ	CR-7	–	1	–	–	–	Thermal comfort design
IEQ	CR-7.1	1	–	1	1	–	Thermal comfort design
IEQ	CR-7.2	1	–	1	1	–	Thermal comfort verification
IEQ	CR-9	–	–	1	–	–	Enhanced acoustical performance
IEQ	CR-10	–	–	1	–	–	Mold prevention
ID	1–5	1–5	1–5	1–4	1–5	1–4	Innovations in design or operations

No credits offered on prerequisite requirements. However, before any credits can be earned, prerequisite requirements must be met.

Definitions:

CI = Commercial Interiors

PR = Prerequisite

MR = Materials and Resources

IEQ = Indoor Air Quality

O&M = Existing Building Operations and Maintenance

EA = Energy and Atmosphere

CR = Credit

RP = Regional Priority

NC = New Construction

K12 = Schools

ID = Innovations in Design

CS = Core and Shell

WE = Water Efficiency

MECHANICAL SPECIFICATIONS

"VRF Multi V™ Mini Air Source Units (036, 047, 053)" on page 96

MECHANICAL SPECIFICATIONS



VRF Multi V™ Mini Air Source Units—ARUN 036, 047, 053

VRF Multi V™ Mini Air Source Units (036, 047, 053)

General

The LG Multi V Mini heat pump system consists of an outdoor unit, one or more indoor units, integrated system controls, and interconnecting field-provided refrigerant pipe containing various fittings including Y-Branch kits and Header kits supplied by LG. LG components are manufactured in a facility that meets or exceeds International Organization for Standardization (ISO) 9001 and 14001. The units are listed by Intertek (ETL) and bear the ETL listed mark.

Casing

The outdoor unit case is constructed from 22-gauge coated metal. Exterior panels are cleaned and finished with a weather resistant baked enamel finish. An easily removable front corner panel is provided to allow access to major components and control devices. Outdoor unit fans are covered with guards made of heavy gauge, heavy duty polymeric resin. The outdoor unit coil is protected with a heavy gauge steel wire guard finished with baked enamel. Paint color is “warm gray.”

Refrigeration System

The refrigeration system consists of a single refrigeration circuit and uses refrigerant R410A. The outdoor unit is provided with factory installed components, including a refrigerant strainer, check valves, oil separator, accumulator, hot gas bypass valve, liquid injection valve, 4-way reversing valve, electronic controlled expansion valve (EEV), high and low side charging ports, service valves, and interconnecting piping. Also included is an integral subcooler assembly consisting of a double spiral tube type heat exchanger and EEV providing refrigerant subcooling modulation up to 23°F. The unit comes factory charged with 6.6 pounds of refrigerant.

Refrigeration Oil Control

The refrigeration oil level in the compressor is maintained using a two-stage oil control system. The compressor discharge port is equipped with an oil filtering device designed to restrict oil loss from the compressor. The high-pressure discharge vapor leaves the compressor and immediately enters a centrifugal oil separator that has no moving parts designed to extract oil from the refrigerant gas stream. A gravity drain returns captured oil back to the compressor sump. The outdoor unit microprocessor is programmed to flush the refrigerant piping system for a minimum period of three minutes after six hours of compressor operation.

Single Inverter/Compressor

The outdoor unit is equipped with one hermetic, digitally-con-

trolled, inverter driven, rotary compressor. The compressor is specifically designed for the refrigerant provided and is manufactured by LG. The frequency inverter is designed by LG and is capable of providing a modulation range from 25Hz–90Hz in Cooling mode and 25Hz–100Hz in Heating mode. The compressor motor is suction gas-cooled and has an acceptable voltage range of ±10% of nameplate voltage. The compressor is equipped with a crankcase heater and back seated service valves.

External suction and discharge temperature and pressure sensors are provided to protect the compressor from damage caused by over/under temperature or over/under pressure conditions. The compressor is provided with a positive displacement oil pump providing sufficient oil film on all bearing surfaces across the entire inverter modulation range. The compressor is factory charged with Polyvinylether (PVE) refrigeration oil having no hygroscopic properties. Compressor bearings are Teflon® coated. The compressor is wrapped with a heat resistant, sound attenuating blanket and mounted on rubber isolation grommets.

Outdoor Unit Coil

Outdoor unit coils are a minimum of two rows, 17 fins per inch, and manufactured using copper tubes with mechanically bonded aluminum louvered fins. Fin surfaces are coated with Gold-Fin™ corrosion resistant hydrophilic silica gel coating. Coils are pressure tested at a minimum of 551 psig.

Fans & Motors

Units are furnished with two direct-drive propeller fans providing horizontal airflow from the rear and discharging from the front of the unit. Fan blades are 20-½ inch diameter, balanced, and made of durable Lupos (ABS) polymeric resin. Motors are designed to operate between 430 and 700 RPM in Cooling mode and between 500 and 750 RPM in Heating mode. Both fans are driven by digitally-controlled inverters that vary the fan speed. Motors are brushless, digitally-controlled (BLDC) and have permanently lubricated and sealed ball bearings. All outdoor unit fans are controlled by an inverter drive mounted near the main microprocessor. The outdoor unit fan speed is controlled using an algorithm that provides three pre-programmed fan speeds. DIP switch adjustable settings limit night time (off peak) fan speed to reduce fan generated noise by up to 10 dB(A).

Outdoor Unit Controls

Outdoor units are factory wired with necessary electrical control components, printed circuit boards, thermistors, sensors, terminal blocks, and lugs for power wiring. The control wiring circuit is low voltage and includes a control power transformer, fuses, and interconnecting wiring harness with plug connectors. Microprocessor-based algorithms provide component protection, soft-start capability, refrigeration system pressure and temperature control, defrost,

and ambient control. The unit is designed to provide continuous compressor operation from -4°F to 118°F. When the system is started, the connected indoor units are automatically assigned an electronic address by the outdoor unit's microprocessor. Additionally, each indoor unit is capable of accepting a manual assignment of a secondary electronic address that, if used, provides unit tag identification when integrating with LG VNet control devices. While operating in the Heating mode, the outdoor unit has a demand-based defrost control algorithm and a refrigeration system pump-down cycle designed to store up to 6.6 lbs of the system refrigerant charge in the outdoor unit. In Heating mode, a cooperative-control algorithm automatically balances, in real-time, the distribution of refrigerant to the indoor units when the system's refrigerant mass flow is insufficient to satisfy the demand of all indoor units when the system is called on to operate outside the system design parameters. In 10-second intervals, the outdoor unit microprocessor will record the last three minutes of system run-time data in non-volatile memory. Upon unit malfunction, or a power outage that results in a system shutdown, the stored system operational data may be retrieved and analyzed to assist in diagnosing a system malfunction. The outdoor unit microprocessor is provided with a three-digit, LED display that communicates active system information and/or malfunction codes. The microprocessor has an algorithm that actively verifies the operational condition of system sensors and thermistors. A refrigerant auto-trim-charge algorithm assists the installer with properly charging the system. A power conditioning circuit is provided and designed to protect the unit's inverter compressor and outdoor unit fan motors from phase failure, phase reversal, sense an under-voltage or over-voltage condition, and to prevent transmission of power irregularities to the supply power source. A snow throw algorithm is provided designed to reduce snow buildup on the discharge side louvers grille at regular intervals.

ACRONYMS

Table 46: Table of Acronyms

%OA	Percentage Outdoor Air	IUCF	Indoor Unit Correction Factor
%RA	Percentage Return Air	KTL	Korea Testing Laboratory
ABS	Acrylonitrile Butadiene Styrene	LEED	Leadership in Energy and Environmental Design
AC	Air Conditioner	LGAP	LG Air Conditioner Protocol
ACP	Advanced Control Platform	MAT	Mixed Air Temperature
ARI	Air Conditioning and Refrigeration Institute	MBh	Thousands BTUs per hour
ASHRAE	American Society of Heating, Refrigeration, and Air Conditioning Engineers	MCA	Maximum Circuit Ampacity
AHU	Air Handling Unit	MFS	Maximum Fuel Size
AWG	American Wire Gauge	MOP	Maximum Overcurrent Protection
BLDC	Brushless DC Motors	MR	Material Resources (LEED Related)
Btu/h	British Thermal Units/hour	NC	New Construction (LEED Related)
CCR	Corrected Capacity Ratio		Normally Closed
CDOA	Coupled Dedicated Outdoor Air	NEC	National Electrical Code
CFM	Cubic Feet per Minute	NO	Normally Open
CI	Commercial Interiors (LEED Related)	OAT	Outdoor Air Temperature
COP	Coefficient Of Performance	O&M	Existing Building Operations and Maintenance (LEED Related)
CR	Combination Ratio	ODU	Outdoor Unit
CS	Core and Shell (LEED Related)	OUCF	Outdoor Unit Correction Factor
DB	Dry Bulb	PDI	Power Distribution Integrator
dB(A)	Decibels with "A" frequency weighting	PI	Power Input
DDOAS	Decoupled Dedicated Outdoor Air	PR	Prerequisite (LEED Related)
DI	Digital Input	PTAC	Packaged Terminal Air Conditioner
DO	Digital Output	PVE	Polyvinyl Ether
EA	Energy and Atmosphere (LEED Related)	RAT	Return Air Temperature
EEV	Electronic Expansion Valve	RCL	Refrigerant Concentration Limit
ELF	Equivalent Length in Feet	RP	Regional Priority (LEED Related)
EPDM	Ethylene Propylene Diene M-Class Rubber	RUR	Running Unit Ratio
ESP	External Static Pressure	K12	Schools (LEED Related)
ETL	Electrical Testing Laboratories	USGBC	U.S. Green Building Council (LEED Related)
HACR	Heating, Air Conditioning, and Refrigeration	VAH	Vertical Air Handler
H/M/L	High/Medium/Low	VAV	Variable Air Volume
IAQ	Indoor Air Quality	VRF	Variable Refrigerant Flow
ID	Innovations in Design (LEED Related)	VRP	Ventilation Rate Procedure
IDU	Indoor Unit	WE	Water Efficiency (LEED Related)
IEQ	Indoor Air Quality (LEED Related)		



Inverter



LG Electronics
Commercial Air Conditioning Division
11405 Old Roswell Road
Alpharetta, Georgia 30009
www.lg-vrf.com

Document Number: EM_MultiVMini_5_15
Supersedes: VRF-EM-BB-US-013E03
VRF-EM-BB-001-US-012M27
VRF-EM-BB-001-US-012D20